

OLYMPUS

DIGITAL CAMERA

E-M1 Mark III

Instruction Manual

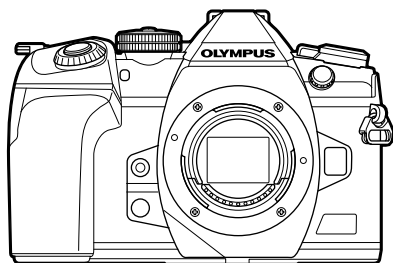

Table of Contents

Feature Index

- 1. Preparation**
- 2. Shooting**
- 3. Playback**
- 4. Menu functions**
Connecting the Camera to External Devices
- 5. External Devices**
- 6. Cautions**
- 7. Information**
- 8. SAFETY PRECAUTIONS**
- 9. Additions/modifications by firmware update**

Model No. : IM019

- Thank you for purchasing an Olympus digital camera. Before you start to use your new camera, please read these instructions carefully to enjoy optimum performance and a longer service life.
- Be sure you have read and understood the contents of "8. SAFETY PRECAUTIONS", before using this product. Keep these instructions available for future reference.
- We recommend that you take test shots to get accustomed to your camera before taking important photographs.
- The screen and camera illustrations shown in this manual were produced during the development stages and may differ from the actual product.
- If there are additions and/or modifications of functions due to firmware update for the camera, the contents will differ. For the latest information, please visit the Olympus website.

In addition to the “Instruction Manual”, we also offer a “Camera Function Guide”. Consult these manuals when using the product.

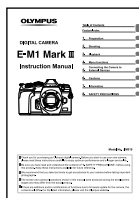

Instruction Manual (this pdf)

A how-to guide to the camera and its features. The Instruction Manual can be downloaded from the OLYMPUS website or directly using the “OLYMPUS Image Share” (OI.Share) smartphone app.

Camera Function Guide

A function and setting guide that helps you use camera features to the full. It has been optimized for display on mobile devices and can be viewed using OI.Share.

<https://cs.olympus-imaging.jp/jp/support/cs/webmanual/index.html>



Indications used in this manual

The following symbols are used throughout this manual.



	Notes and other supplementary information.
	Tips and other helpful information for using the camera.
	References to other pages in this manual.

Table of Contents

Product Manuals	2	2. Shooting	36
Before You Begin	11	■ Information displays while shooting	36
Feature Index	12	■ Switching between displays	38
Names of parts	16	Switching the information display	39
1. Preparation	18	■ Shooting still pictures	41
■ Unpacking the box contents	18	Shooting with touch screen operations.....	43
■ Attaching the Strap	19	Letting the camera choose aperture and shutter speed (P : Program AE).....	44
■ Charging and inserting the battery	20	Choosing aperture (A : Aperture-Priority AE)	46
■ Using External Power Sources	22	Choosing shutter speed (S : Shutter-Priority AE)	48
Connecting via USB	22	Choosing aperture and shutter speed (M : Manual Exposure).....	50
HLD-9 Power Battery Holder.....	24	Long Exposures (B : Bulb/Time)...	52
■ Inserting the card	26	Lighten Blending (B : Live Composite Photography).....	54
Using Two Memory Cards	27	■ Saving Custom Settings to the Mode Dial (C1/C2/C3/C4 Custom Modes)	56
■ Attaching a lens to the camera	28	Saving Settings (Assign to Custom Mode).....	56
■ Removing Lenses	30	Using Custom Modes (C1/C2/C3/C4)	57
■ Using the monitor	31	■ Recording Movies	59
■ Turning the camera on	32	Recording movies in photo shooting modes	59
Sleep Mode	32	Recording movies in movie mode (MOV)	60
■ Initial setup	33	Touch Controls (Silent Controls)...	61
■ What to Do If You Can't Read the Display	35		

Shooting Settings	62	The Super Control/LV Super Control Panel.....	88
Direct Buttons.....	63	Changing ISO sensitivity (ISO).....	91
Choosing a focus mode (AF Mode).....	64	Choosing a focus mode (AF Mode).....	91
Controlling exposure (Exposure Compensation).....	68	Positioning and Sizing the AF Target (AF Area).....	91
Choosing an AF Target Mode (AF Target Mode).....	69	Choosing how the camera measures brightness (Metering).....	92
Choosing a Focus Target (AF Target Point).....	72	Face priority AF/Eye priority AF (☺ Face Priority).....	92
Zoom frame AF/Zoom AF (Super Spot AF).....	73	Adjusting color (WB (white balance)).....	94
Changing ISO sensitivity (ISO).....	75	Making fine adjustments to white balance (WB Compensation).....	96
Choosing how the camera measures brightness (Metering).....	77	Reducing camera shake (Image Stabilizer).....	97
Locking the exposure (AE Lock).....	77	Performing the sequential/self-timer shooting.....	98
Performing the sequential/self-timer shooting.....	78	Setting the image aspect.....	98
Self-Timer Options (⌚ Custom Self-timer).....	80	Setting the saving method for shooting data (📷 Save Settings).....	99
Shooting without the vibration caused by shutter button operations (Anti-Shock [⬆]).....	80	Photo File and Image Size Options (📷🔍).....	100
Shooting without shutter sound (Silent [♥]).....	81	Frame Size, Rate, and Compression (📷🔍).....	101
Shooting without a release time lag (Pro Capture shooting).....	81	Filming Slow- or Fast-Motion Movies (Slow- and Fast-Motion Movies).....	104
Shooting still pictures in a higher resolution (High Res Shot).....	83	Choosing a Flash Mode (Flash Mode).....	105
Using a flash (Flash photography).....	84	Adjusting flash output (🔦).....	105
Choosing a Flash Mode (Flash Mode).....	86		

Processing options (Picture Mode).....	106
Adjusting overall color (Color Creator).....	108
“Leave Color” Effects (Partial Color).....	109
Making fine adjustments to sharpness (Sharpness).....	110
Making fine adjustments to contrast (Contrast).....	110
Making fine adjustments to saturation (Saturation).....	110
Making fine adjustments to tone (Gradation).....	111
Applying filter effects to monochrome pictures (Color Filter).....	112
Adjusting the tone of a monochrome image (Monochrome Color).....	113
Adjusting i-Enhance effects (Effect).....	113
Setting the color reproduction format (Color Space).....	114
Changing the brightness of highlights and shadows (Highlight&Shadow Control) ...	115
Assigning functions to buttons (Button Function).....	116

3. Playback 126

■ Information display during playback	126
Playback image information	126
Switching the information display	127
■ Viewing photographs and movies	128
Finding Pictures Quickly (Index and Calendar Playback).....	129
Zooming In (Playback Zoom).....	129
Rotating Pictures (Rotate).....	130
Watching movies	130
Protecting Pictures (Ⓞ).....	131
Copying an image (Copy).....	131
Deleting Pictures (Erase).....	132
Selecting Pictures for Sharing (Share Order).....	132
Selecting Multiple Pictures (Ⓞ, Copy Select, Erase Selected, Share Order Selected).....	133
Print order (DPOF).....	134
Adding Audio to Pictures (🎧).....	136
■ Playback Using Touch Controls	137
Selecting and protecting images.....	138

4. Menu functions	139
■ Basic menu operations	139
■ Using Shooting Menu 1/ Shooting Menu 2	141
Restoring Default Settings (Reset).....	141
Saving Settings (Assign to Custom Mode).....	142
Processing options (Picture Mode).....	142
Photo File and Image Size Options (📷⏪).....	142
Digital Zoom (Digital Tele-converter)	143
Shooting automatically with a fixed interval (Intrvl. Sh./Time Lapse)	144
Varying settings over a series of photographs (Bracketing).....	146
Taking HDR (High Dynamic Range) images (HDR).....	152
Recording multiple exposures in a single image (Multiple Exposure).....	154
Keystone correction and perspective control (Keystone Comp.).....	156
Setting anti-shock/silent shooting (Anti-Shock [📷]/Silent [📷])	157
Setting high resolution shooting (High Res Shot).....	158
Slowing the Shutter in Bright Light (Live ND Shooting)	159
■ Using the Video Menu	161
Choosing an Exposure Mode (📷 Mode (Movie Exposure Modes))	165
Reducing Flicker Under LED Lighting (📷 Flicker Scan)	166
Frame Size, Rate, and Compression (📷⏪).....	167
Assigning Roles to the Front and Rear Dials (📷 Dial Function).....	168
Sound Recording Options (Movie 🎤)	169
■ Using the Playback Menu	170
Automatically Rotating Portrait- Orientation Pictures for Playback (📷).....	170
Retouching Pictures (Edit).....	170
Combining Pictures (Image Overlay).....	172
Creating Movie Stills (In-Movie Image Capture)	173
Trimming movies (Movie Trimming).....	174
Removing Protection from All Pictures (Reset Protect)	175
Cancelling a share order (Reset share Order)	175
Copying All Pictures (Copy All)...	175
■ Using the setup menu	176
Formatting the card (Card Setup).....	177
Deleting all images (Card Setup).....	177
Wireless LAN Options (Wi-Fi/Bluetooth Settings)	178

Using “My Menu”	179	Combined Auto and Manual Focus (📷 AF+MF)	200
Using the custom menus	181	Setting Focus and Exposure with the AEL/AFL Button (📷 AEL/AFL)	201
A1 AF/MF	181	C-AF Tracking Sensitivity (📷 C-AF Sensitivity)	203
A2 AF/MF	182	C-AF Starting Focus Target (📷 C-AF Center Start)	204
A3 AF/MF	183	C-AF Center Target Priority (📷 C-AF Center Priority)	205
A4 AF/MF	184	Choosing the AF Home Position ([⋮]) Set Home)	206
B1 Button/Dial/Lever	185	AF-Target Selection ([⋮]) Select Screen Settings).....	207
B2 Button/Dial/Lever	185	Enabling AF-Target Selection Wrap ([⋮]) Loop Settings)	208
C1 Release/📷/ Image Stabilizer.....	186	AF Target Size and Positioning ([⋮] Target Mode Settings).....	209
C2 Release/📷/ Image Stabilizer.....	186	Matching AF-Target Selection to Camera Orientation (📷 Orientation Linked [⋮]).....	210
D1 Disp/📷)/PC	187	Lens Focus Range (AF Limiter).....	211
D2 Disp/📷)/PC	188	Fine-Tuning Autofocus (AF Focus Adj.).....	212
D3 Disp/📷)/PC	189	Manual Focus Assist (MF Assist)	215
D4 Disp/📷)/PC	190	Adjusting Focus During Exposures (Bulb/Time Focusing)	216
E1 Exp/ISO/BULB/📷	191		
E2 Exp/ISO/BULB/📷	192		
E3 Exp/ISO/BULB/📷	193		
F ⚡ Custom	193		
G 📷/WB/Color	194		
H1 Record/Erase	195		
H2 Record/Erase	196		
I EVF	196		
J1 📷 Utility	198		
J2 📷 Utility	198		

Multi Selector Press ( Center Button)	217
Multi Selector Tilt ( Direction Key)	217
Assigning Roles to the Front and Rear Dials ( Dial Function)....	218
Customizing the Fn Lever ( Fn Lever Function).....	219
Burst Shooting Options ( L Settings/  H Settings)	220
Reducing Flicker (Flicker Reduction)	222
Choosing the control panel displays ( Control Settings) ...	224
Adding information displays ( Info Settings).....	226
Choosing the Playback Zoom Ratio ( Default Setting).....	229
Selfie Assist (Selfie Assist)	229
Viewing camera images on TV (HDMI).....	230
Choosing a USB Connection Mode (USB Mode).....	231
Live Bulb Update Frequency (Live Bulb)	232
Live Time Update Frequency (Live Time).....	232
Choosing the Shutter Speed (Composite Settings).....	233
Reducing Flicker Under LED Lighting ( Flicker Scan)	234
Fine-Tuning Exposure (Exposure Shift).....	235
Shutter speeds when the flash fires ( X-Sync./  Slow Limit)....	236
Combinations of JPEG image sizes and compression rates ( Set).....	236
Setting the card to record to (Card Slot Settings).....	237
Saving lens info (Lens Info Settings)	239
Selecting the display style of the viewfinder (EVF Style).....	240
Viewfinder Info Display Options ( Info Settings)	241
Button Hold Options (Press-and-hold Time).....	241
Correcting Fisheye Distortion (Fisheye Compensation)	242

5. Connecting the Camera to External Devices 244

- **Precautions for Using Wi-Fi
and Bluetooth®** 244
- **Connecting to Smartphones
via Wi-Fi.....** 245
 - Installing Apps
 - Connecting to Smartphones
(Wi-Fi/Bluetooth Settings)
 - Connecting When the Camera Is
Off (Power-off Standby).....
 - Copying Pictures to
Smartphones
 - Remote Photography Using a
Smartphone.....
 - Adding position information to
images.....
 - Ending the Connection

■ Connecting to Computers via Wi-Fi	256
Installing Software	256
Readying the Computer (Windows)	257
Pairing the Computer with the Camera (New Link)	258
Adjusting Wi-Fi Settings ((Wi-Fi Connect))	260
Uploading Pictures as They Are Taken	268
Ending the Connection	270
■ Network Settings	272
Changing Passwords (Connection Password)	272
Restoring Default Wi-Fi/Bluetooth® Settings (Reset Settings).....	273
■ Connecting to Computers via USB	274
Compatible Computers.....	274
Installing Software	274
Uploading Pictures as They Are Taken (PC RAW)	275
Connecting the Camera for High-Speed RAW Processing (PC RAW)	276
Copying Pictures to the Computer (Storage/MTP).....	277
■ Powering the Camera via USB (USB Power Delivery)	278
■ Connecting to TVs or External Displays via HDMI	279
Viewing Pictures on a TV (HDMI).....	280
Using a TV Remote (HDMI Control)	282
6. Cautions	283
■ Battery and charger	283
■ Using your charger abroad	284
■ Usable cards	284
■ Interchangeable lenses	285
■ MF Clutch Lenses	286
■ Optional Accessories	287
Designated External Flash Units	287
Wireless remote control flash photography	288
Other external flash units	290
Principal Accessories	291
■ System chart	292

7. Information	294
■ Cleaning and storing the camera	294
Cleaning the camera	294
Storage.....	294
Cleaning and checking the image pickup device.....	295
Pixel Mapping - Checking the image processing functions.....	295
■ Shooting tips and information	296
■ Error codes	299
■ Default Settings	301
■ Memory Card Capacity	316
■ Specifications	318
8. SAFETY PRECAUTIONS	321
■ SAFETY PRECAUTIONS	321
9. Additions/modifications by firmware update	326
Index	330

Before You Begin

Read and Follow “8. SAFETY PRECAUTIONS”

To prevent incorrect operation resulting in fire or other damage to property or harm to yourself or to others, read “8. SAFETY PRECAUTIONS” (P. 321) in its entirety before using the camera.

While using the camera, consult this manual to ensure safe and correct operation. Be sure to keep the manual in a safe place once it is read.

Olympus will not be held liable for violations of local regulations arising from use of this product outside the country or region of purchase.

- Use of these features outside the country or region of purchase may violate local wireless regulations; be sure to check with local authorities before use. Olympus will not be held liable for the user's failure to comply with local regulations.

Wireless LAN and Bluetooth®

The camera features built-in wireless LAN and **Bluetooth®**. Use of these features outside the country or region of purchase may violate local wireless regulations; be sure to check with local authorities before use. Olympus will not be held liable for the user's failure to comply with local regulations.

Disable wireless LAN and **Bluetooth®** in areas where their use is prohibited.

 “Disabling Wi-Fi/**Bluetooth®**” (P. 255, 271)













■ User Registration

















Visit the OLYMPUS website for information on registering your OLYMPUS products.

Feature Index

Feature	
Shooting Mode	41
Custom Mode	57
Monitor Display	39, 127
Viewfinder Display	240
Direct Button Functions	63
Live Controls	225
LV Super Control Panel	88, 90
Shooting Menu 1	
Reset / Custom Modes	141
Picture Mode	106, 142
	100, 142
Image Aspect	98
Digital Tele-converter	143
/ (Drive Mode)	78, 98
Intrvl. Sh./Time Lapse	144
Shooting Menu 2	
Bracketing	146
HDR	152
Multiple Exposure	154
Keystone Comp.	156
Anti-Shock []/Silent [157
High Res Shot	83, 158
Live ND Shooting	159
Video Menu	
Mode Settings	
Mode	165
Flicker Scan	166





Feature	
Specification Settings	
	167
M ISO-Auto Set	161
Noise Filter	161
WB	161
All	161
^{WB} AUTO Keep Warm Color	161
Picture Mode	161
AF/IS Settings	
AF Mode	64, 91
C-AF Speed	162
C-AF Sensitivity	162
Image Stabilizer	97
IS Level	162
Button/Dial/Lever	
Button Function	116
Dial Function	163
Fn Lever Function	163
Shutter Function	163
Elec. Zoom Speed	163
Display Settings	
Control Settings	164
Info Settings	164
Time Code Settings	164
Display Pattern	164
View Assist	164
Movie	169
HDMI Output	164





Feature	
▶ Playback Menu	
	170
Edit	170
Print Order	134
Reset Protect	175
Reset share Order	175
Copy All	175
 Wi-Fi Connect	247
⚙ Custom Menu	
A1 AF/MF	
 AF Mode	64
 AF+MF	200
 AEL/AFL	201
AF Scanner	181
 C-AF Sensitivity	203
 C-AF Center Start	204
 C-AF Center Priority	205
A2 AF/MF	
 [::] Mode Settings	182
AF Area Pointer	182
[::] Set Home	206
[::] Select Screen Settings	207
[::] Loop Settings	208
[::] Target Mode Settings	209
 Orientation Linked [::]	210
A3 AF/MF	
AF Targeting Pad	183
AF Limiter	183
AF Illuminator	183
 Face Priority	92
AF Focus Adj.	183

Feature	
A4 AF/MF	
Starry Sky AF Setting	184
Preset MF distance	184
MF Assist	215
MF Clutch	184
Focus Ring	184
Bulb/Time Focusing	216
Reset Lens	184
B1 Button/Dial/Lever	
 Button Function	116
 Center Button	217
 Direction Key	217
 Dial Function	185
Dial Direction	185
 Fn Lever Function	219
Fn Lever/Power Lever	185
B2 Button/Dial/Lever	
 Elec. Zoom Speed	185
 Function	185
 Lock	185
 Lock	185
C1 Release/ Image Stabilizer	
S-AF Release Priority	186
C-AF Release Priority	
 L Settings	220
 H Settings	
Flicker Reduction	222
C2 Release/ Image Stabilizer	
 Image Stabilizer	97
 Image Stabilizer	186
Half Way RIs With IS	186
Lens I.S. Priority	186

Feature	
D1 Disp/■)/)/PC	
Control Settings	224
/Info Settings	226, 228
Picture Mode Settings	187
/🔄 Settings	187
Multi Function Settings	187
D2 Disp/■)/)/PC	
Live View Boost	188
Art LV Mode	188
Frame Rate	188
LV Close Up Settings	188
🔍 Default Setting	229
Settings	189
D3 Disp/■)/)/PC	
Grid Settings	189
Peaking Settings	189
Histogram Settings	189
Mode Guide	189
Selfie Assist	229
D4 Disp/■)/)/PC	
■)/)	190
HDMI	230
USB Mode	190
E1 Exp/ISO/BULB/📷	
EV Step	191
ISO Step	191
ISO-Auto Set	191
ISO-Auto	191
Noise Filter	191
Low ISO Processing	191
Noise Reduct.	192







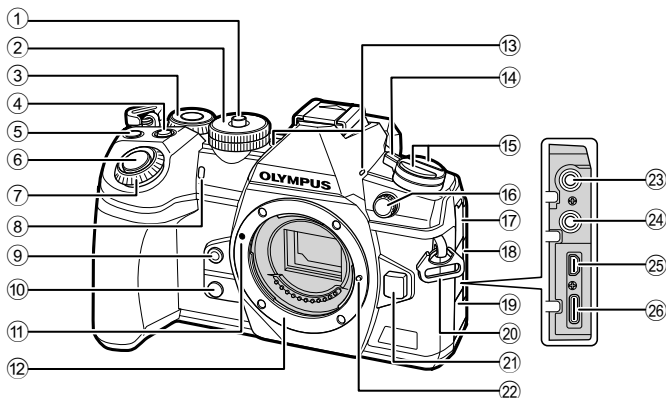

Feature	
E2 Exp/ISO/BULB/📷	
Bulb/Time Timer	192
Live Composite Timer	192
Bulb/Time Monitor	192
Live Bulb	232
Live Time	232
Composite Settings	233
Flicker Scan	234
E3 Exp/ISO/BULB/📷	
Metering	77
AEL Metering	193
[::] Spot Metering	193
Exposure Shift	193
F ⚡ Custom	
⚡ X-Sync.	236
⚡ Slow Limit	236
+	193
⚡ +WB	193
⚡ RC Mode	288
G ⬅️-/WB/Color	
⬅️- Set	100, 142, 236
Pixel Count	100, 142, 236
Shading Comp.	194
WB	94
All	194
^{WB} _{AUTO} Keep Warm Color	94, 96
Color Space	114

Feature	
H1 Record/Erase	
Card Slot Settings	237
File Name	195
Edit Filename	195
dpi Settings	195
Copyright Settings	195
Lens Info Settings	239
H2 Record/Erase	
Quick Erase	196
RAW+JPEG Erase	196
Priority Set	196
I EVF	
EVF Auto Switch	196
EVF Adjust	196
EVF Style	240
 Info Settings	196
EVF Grid Settings	197
 Half Way Level	197
S-OVF	197
I1  Utility	
Pixel Mapping	295
Press-and-hold Time	198
Level Adjust	198
Touchscreen Settings	198
Menu Recall	198
Fisheye Compensation	242

Feature	
I2  Utility	
Battery Settings	198
Backlit LCD	198
Sleep	32
Auto Power Off	199
Quick Sleep Mode	199
Certification	199
Y Setup Menu	
Card Setup	177
 Settings	33
 35	35
 176	176
Rec View	176
Wi-Fi/Bluetooth Settings	178
Firmware	176
My Menu	179

Names of parts



- ① Mode dial lock.....P. 41
- ② Mode dial P. 41
- ③ Rear dial* (☺)
.....P. 44–50, 124, 128, 228
- ④  (Exposure compensation) button
.....P. 45, 47, 49, 51, 68
- ⑤  (Movie)/ button.....P. 59/P. 133
- ⑥ Shutter button P. 42
- ⑦ Front dial* (☺)
.....P. 44–50, 75, 124, 128
- ⑧ Self-timer lamp/AF illuminator
.....P. 78, 98/P. 183
- ⑨  (One-touch white balance) button
.....P. 95
- ⑩  (Preview) button P. 117
- ⑪ Lens attachment markP. 28
- ⑫ Mount (Remove the body cap before
attaching the lens.)
- ⑬ Stereo microphoneP. 136, 169
- ⑭ **ON/OFF** lever P. 32
- ⑮  buttonP. 185
AF  (AF/metering mode) button
.....P. 64, 77
 (Sequential shooting/self-timer/
flash) button.....P. 78
- ⑯ External flash terminalP. 84
- ⑰ Microphone jack cover
- ⑱ Cover for headphone jack.....P. 169
- ⑲ Connector cover
- ⑳ Strap eyelet.....P. 19
- ㉑ Lens release buttonP. 30
- ㉒ Lens lock pin
- ㉓ Microphone jack (ø3.5 mm stereo mini-
jack for third-party microphones)...P. 169
- ㉔ Headphone jack (ø3.5 mm stereo mini-
jack for third-party headphones)...P. 169
- ㉕ HDMI connector (Type D).....P. 230
- ㉖ USB connector (Type C)
.....P. 258, 275, 277

* In this manual, the ☺ and ☹ icons represent operations performed using the front dial and rear dial.

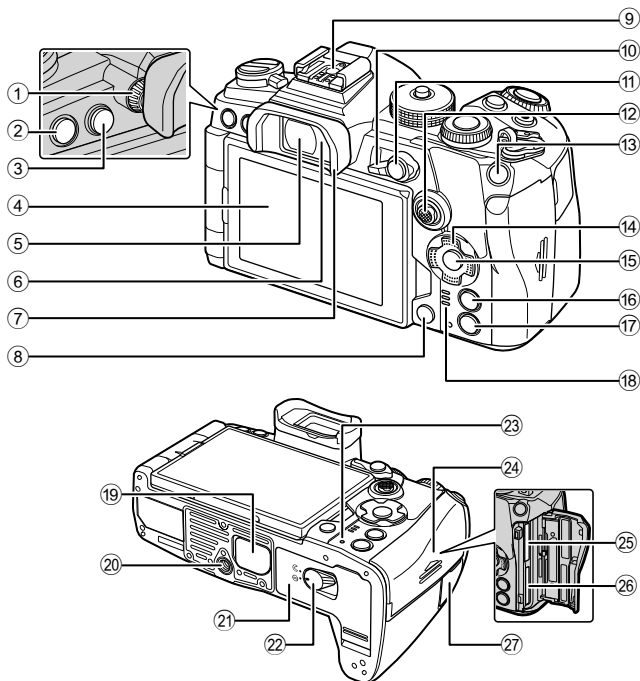

- | | |
|--|--|
| ① Diopter adjustment dial.....P. 38 | ⑭ Arrow pad *2P. 128 |
| ② MENU button.....P. 139 | ⑮ OK buttonP. 88, 128, 139 |
| ③ LV buttonP. 38 | ⑯ INFO buttonP. 39, 127 |
| ④ Monitor (Touch screen)
.....P. 36, 38, 43, 88, 126, 137 | ⑰ ▶ (Playback) button.....P. 128 |
| ⑤ ViewfinderP. 38, 240 | ⑱ Speaker |
| ⑥ Eye sensor | ⑲ Tripod cover.....P. 24 |
| ⑦ Eyecup.....P. 291 | ⑳ Tripod socket |
| ⑧ ⏮ (Erase) buttonP. 132 | ㉑ Battery compartment cover.....P. 20 |
| ⑨ Hot shoeP. 84, 287 | ㉒ Battery compartment lock.....P. 20 |
| ⑩ Fn leverP. 44–50, 219 | ㉓ CHARGE (Battery charge) lamp ...P. 22 |
| ⑪ AEL/AFL / Protect button
.....P. 77, 201/P. 131 | ㉔ Card compartment coverP. 26 |
| ⑫ Multi selector (⦿ / ⦿) *1P. 69, 72 | ㉕ Card slot 1P. 26 |
| ⑬ ISO button.....P. 75, 226 | ㉖ Card slot 2P. 26 |
| | ㉗ Remote cable terminal cover
(Remote cable terminal)P. 291 |

*1 The multi selector is designed to be used in two ways. You can place a finger lightly on the multi selector and pivot it in the desired direction (**⦿**). You can also press down on the center of the multi selector much as you would a button (**⦿**).

*2 In this manual, the **Δ** **▽** **◀** **▶** icons represent operations performed using the arrow pad.

Unpacking the box contents

At purchase, the package contains the camera and the following accessories. If anything is missing or damaged, contact the dealer from whom you purchased the camera.



Camera



Body cap*

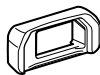

EP-12 eyecup*



Hot shoe cover*



Strap

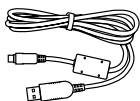

CB-USB11 USB cable

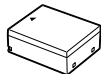
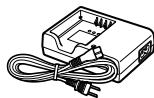
BLH-1 rechargeable
lithium-ion batteryBCH-1 charger for
lithium-ion batteries

CC-1 cable clip

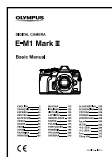

Basic Manual

- Warranty Card

* The body cap, eyecup, and hot shoe cover attached to or inserted in the camera.

Attaching the Strap

- 1 Before attaching the strap, remove the end from the keeper loop and loosen the strap as shown.

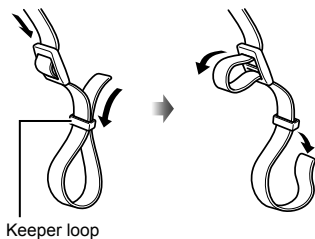

- 2 Pass the end of the strap through the strap eyelet and back through the keeper loop.



- 3 Pass the end of the strap through the buckle and tighten as shown.

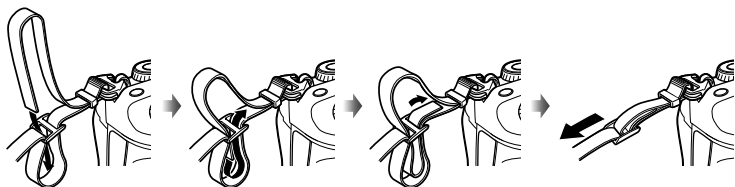

- Attach the other end of the strap to the other eyelet.
- After attaching the strap, pull on it firmly to ensure that it will not come loose.

Attaching the cable clip

Use the cable clip to secure the cable, then attach it to the strap.

The cable clip can also be attached to the strap eyelet.

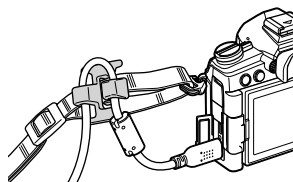

Charging and inserting the battery

1 Charge the battery.

Charging indicator

Charging in progress	Less than 50%	Blinks in orange 1 time/second
	50% or more Less than 80%	Blinks in orange 2 times/second
	80% or more Less than 100%	Blinks in orange 3 times/second
Charging complete		Lights up in green
Charging error		Blinks in green 5 times/second

(Charging time: Approximately 2 hours)

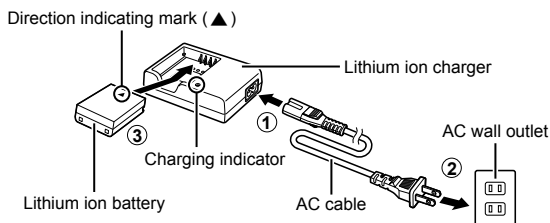

- Unplug the charger when charging is complete.
- Batteries inserted in the camera will charge when the camera is connected to an external device via USB.  "Charging via USB" (P. 22)

2 Confirm that the camera is off.

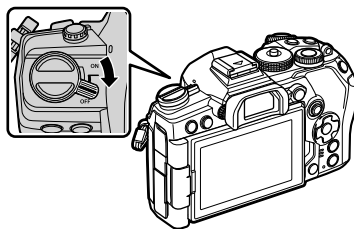

3 Open the battery compartment cover.

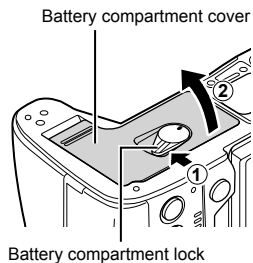

4 Loading the battery.

- Use only BLH-1 batteries (P. 18, 320).

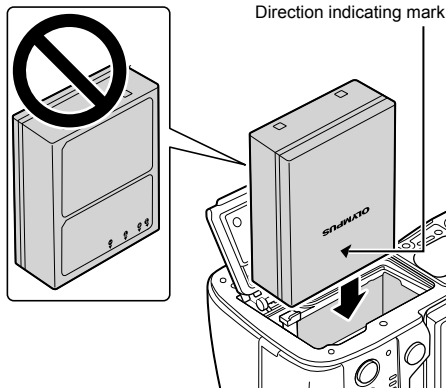

5 Close the battery compartment cover.



- It is recommended to set aside a backup battery for prolonged shooting in case the battery in use drains.
- Also read "Battery and charger" (P. 283).

■ Removing the battery

Turn off the camera before opening or closing the battery compartment cover. To remove the battery, first push the battery lock knob in the direction of the arrow and then remove.

- Contact an authorized distributor or service center if you are unable to remove the battery. Do not use force.
- Never remove batteries or memory cards while the memory card access indicator (P. 36, 37) is displayed.

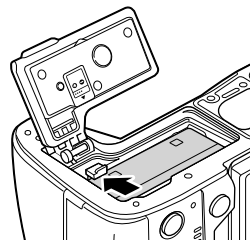

Using External Power Sources

1

Preparation

Connecting via USB

The battery inserted in the camera will charge when the camera is connected via a USB cable to a USB device such as a computer or to an optional USB-AC adapter such as the F-5AC. The battery charges only when the camera is off.

Devices that conform to the USB Power Delivery (USB PD) standard can also be used to power the camera.  "Powering the Camera via USB (USB Power Delivery)" (P. 278)

■ Charging via USB

1 Confirm that the camera is off.

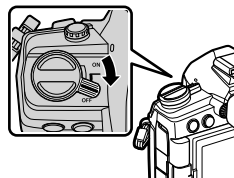

2 Connect the camera to the external device via USB.

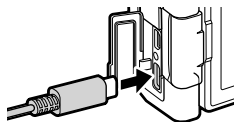

- The **CHARGE** lamp light during charging. Charging times vary with the output of the USB device. The lamp goes out as the batteries reach full charge.

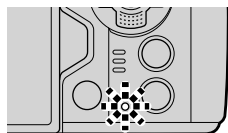

3 Charging stops when the camera is turned on.

- The battery cannot be charged via USB when the camera is on.
- If a charging error occurs, the **CHARGE** lamp will blink. Disconnect and reconnect the USB cable.
- USB charging is available when the battery temperature is between 0 and 40 °C.
- Batteries inserted in optional HLD-9 power battery holders will not charge (P. 24).



- The supply of power ends when the battery is charged. Disconnect and reconnect the USB cable to resume charging.
- The battery will not charge while the camera is off if pictures are being uploaded to a smartphone via Wi-Fi (background auto upload).  "Connecting When the Camera Is Off (Power-off Standby)" (P. 249)

■ Powering the Camera via USB

The camera can be powered using mobile batteries or similar devices connected via USB. The devices must:

Standard: Conform to the USB Power Delivery (USB PD) standard

Output: Be rated for an output of 9 V 3 A, 15 V 2 A, or 15 V 3 A

For more information, see “Powering the Camera via USB (USB Power Delivery)” (P. 278).

HLD-9 Power Battery Holder

An optional HLD-9 battery holder can be used to power the camera for extended periods. You can assign functions to the arrow pad and **B-Fn** button using the camera [Button Function] options. The optional AC adapter can be used with the HLD-9. Make sure to turn the camera off when attaching and removing the holder.

■ Part names

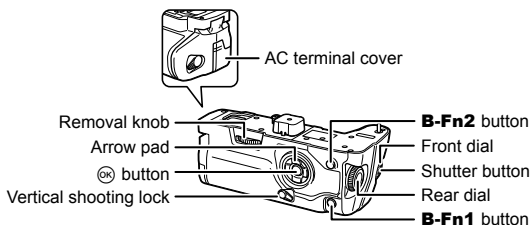

■ Attaching the holder

Remove the PBH cover (a) on the bottom of the camera before attaching the HLD-9. Once attached, make sure the HLD-9 removal knob is tightly secured. Make sure to attach the PBH cover to the camera when not using the HLD-9.

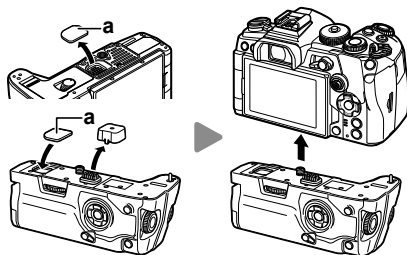

Store the PBH cover (a) in the HLD-9.

■ Loading the battery

Use BLH-1 battery. Once you load the battery, make sure to lock the battery cover.

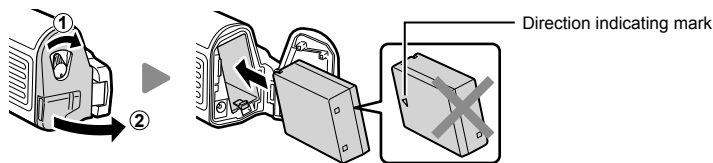

- The monitor battery-level indicator (P. 32) shows **PBH** when the camera is powered by the battery in the HLD-9.



■ Using the AC adapter (AC-5)

Open the AC terminal cover and connect the optional AC-5 AC adapter to the AC terminal.

- The AC adapter cannot be used to charge the camera battery.

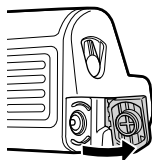

■ Using the buttons

The roles performed by the arrow pad and **B-Fn** buttons on the HLD-9 can be selected using the [Button Function] item.  "Assigning functions to buttons (Button Function)" (P. 116)

■ Main Specifications (HLD-9)

Power Supply	Battery: BLH-1 Lithium-ion Battery × 1 AC power: AC-5 AC Adapter
Dimensions	Approx. 132.7 mm (W) × 55.8 mm (H) × 66.0 mm (D) (5.2" × 2.2" × 2.6")
Weight	Approx. 255 g (9.0 oz.) (excluding battery and terminal cap)
Splash resistance (when attached to camera)	Type Equivalent to IEC Standard publication 60529 IPX1

- Use only the designated battery and AC adapter. Failure to do so could result in injury, damage to the product, and fire.
- Do not use your nail to turn the removal knob. Doing so could result in injury.
- Only use the camera within the guaranteed operating temperature range.
- Do not use or store the product in dusty or humid areas.
- Do not touch the electrical contacts.
- Use a dry, soft cloth to clean the terminals. Do not clean the product with a damp cloth, thinner, benzene, or any other organic solvents.
- Remove the batteries before putting the camera into storage for periods of a month or more. Leaving the batteries in the camera for extended periods shortens their lives, potentially rendering them unusable.

Inserting the card

The camera uses third-party SD, SDHC, or SDXC memory cards conforming to the SD (Secure Digital) standard. Read "Usable cards" (P. 284) before use.

- 1 Confirm that the camera is off.

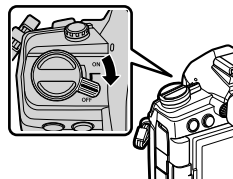

- 2 Open the card compartment cover.
 - The camera has two card slots.

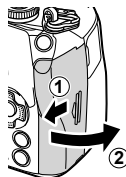

- 3 Slide the card in until it locks into place.
 - Do not forcibly insert a damaged or deformed card. Doing so may damage the card slot.

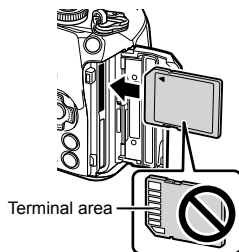

- 4 Close the card compartment cover.
 - Close it securely until you hear it click.
 - Be sure the card compartment cover is closed before using the camera.
 - Cards must be formatted with this camera before first use (P. 177).

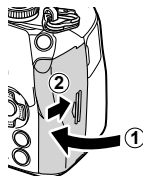

■ Removing the card

Press the card in to eject it. Pull out the card.

- Confirm that the camera is off before removing memory cards.
- Never remove batteries or memory cards while the memory card access indicator (P. 36, 37) is displayed.

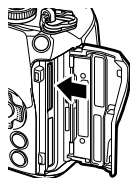

Card Slots 1 and 2 support different types of memory card.

- Slot 1: Supports UHS-II and UHS-I
- Slot 2: Supports UHS-I*
 - * UHS-II cards function as UHS-I cards when inserted in Slot 2.

Card slot 1

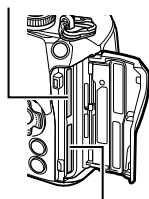

Card slot 2

Using Two Memory Cards

When two memory cards are inserted, you can choose how each card is used according to your goals. Custom Menu > [Card Slot Settings] (P. 237)

- Record only to a selected card
- Record to a selected card until it is full, then record to the second card
- Record pictures with different sizes or compression ratios to different cards
- Record copies of each picture to both cards

Attaching a lens to the camera

- See page 285 for information on compatible lenses.

1 Confirm that the camera is off.

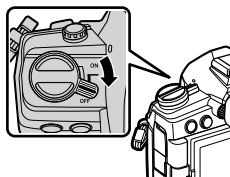

2 Remove the rear cap of the lens and the body cap of the camera.

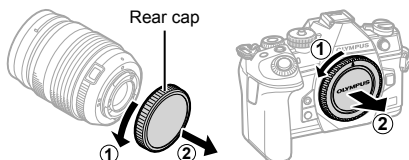

3 Align the lens attachment mark (red) on the camera with the alignment mark (red) on the lens, then insert the lens into the camera's body.

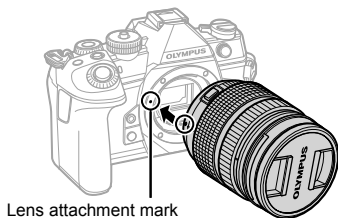

4 Rotate the lens clockwise until you hear it click (direction indicated by arrow ③).

- Do not press the lens release button.
- Do not touch internal portions of the camera.

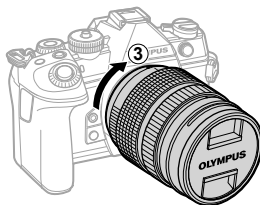

5 Remove the front lens cap.

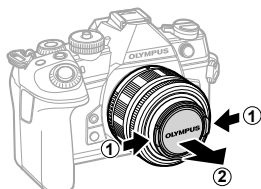
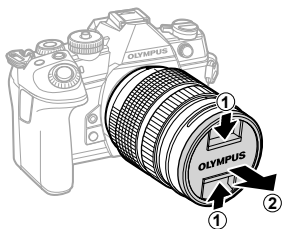

Removing Lenses

- 1 Confirm that the camera is off.

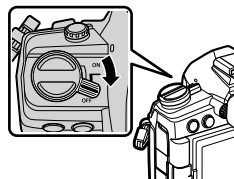

- 2 Hold the lens release button and rotate the lens as shown.



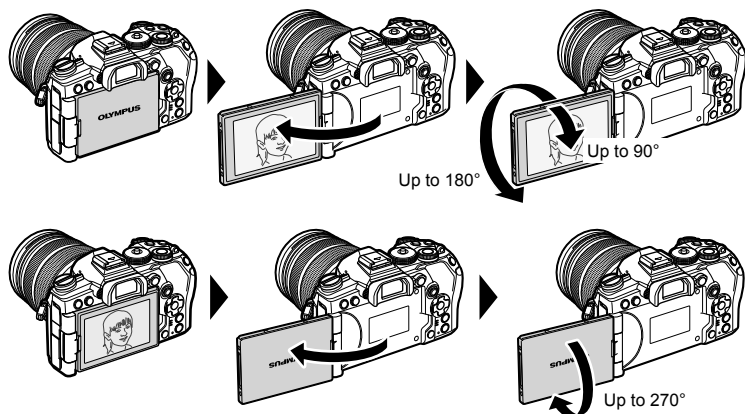

Using the monitor

Rotate the monitor for ease of viewing. The angle of the monitor can be adjusted according to conditions at the time of shooting.

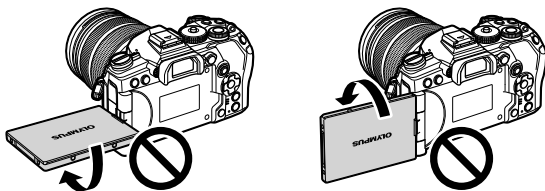

- Gently rotate the monitor within its range of motion. Attempting to rotate the monitor beyond the limits shown below could damage the connectors.



- The camera can be configured to display a mirror image of the view through the lens or automatically zoom power zoom lenses all the way out when the monitor is rotated for self portraits.  "Selfie Assist (Selfie Assist)" (P. 229)

Turning the camera on

- 1 Set the **ON/OFF** lever to the **ON** position.
 - When the camera is turned on, the monitor will turn on.
 - To turn the camera off, return the lever to the **OFF** position.

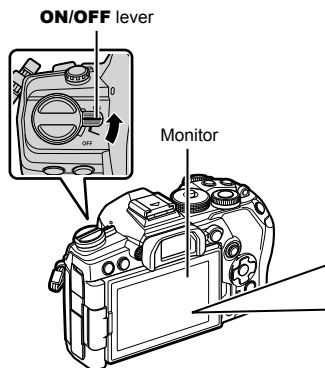

Battery level

The camera displays the level of the battery currently in use. The battery level is shown in 10 increments.

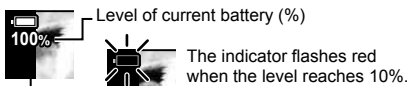

- The **Fn** lever can be configured to turn the camera on and off using the [Fn Lever/Power Lever] option (P. 185) in **Custom Menu B1**.

Sleep Mode

If no controls are used for a set period, the camera will automatically enter suspend operation to reduce the drain on the batteries. This is referred to as "sleep mode".

- When the camera enters sleep mode, the monitor will turn off and operation will be suspended. Pressing the shutter or **▶** button reactivates the camera.
- If no operations are performed for a set period after the camera enters sleep mode, the camera will turn off automatically. The camera can be reactivated by turning it on again.
- The camera may require additional time to recover from sleep mode when [On] (enabled) is selected for [Wi-Fi/Bluetooth Settings] > [Power-off Standby]. **ⓘ** "Connecting When the Camera Is Off (Power-off Standby)" (P. 249)
- The delay before the camera goes to sleep or turns off automatically can be selected in the **⚙** custom menu. At default settings, the camera will go to sleep after one minute and turn off automatically after four hours. **ⓘ** **⚙** Custom Menu **U2** > [Sleep] (P. 199), [Auto Power Off] (P. 199)

Initial setup

After turning the camera on for the first time, perform the initial setup by choosing a language and setting the camera clock.

- Date and time information is recorded on the card together with the images.
- The file name is also included with the date and time information. Be sure to set the correct date and time before using the camera. Some functions cannot be used if the date and time have not been set.

- 1 Press the **OK** button when the initial setup dialog is displaying prompting you to choose a language.

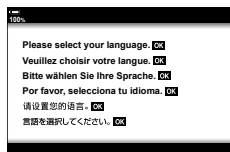

- 2 Highlight the desired language using the front or rear dial or the **△ ▽ ◀ ▶** buttons on the arrow pad.

- The language-selection dialog has two pages of options. Use the front or rear dial or the **△ ▽ ◀ ▶** buttons on the arrow pad to move the cursor between pages.



- 3 Press the **OK** button when the desired language is highlighted.

- If you press the shutter button before pressing the **OK** button, the camera will exit to shooting mode and no language will be selected. You can perform the initial setup by turning the camera off and then on again to display the initial setup dialog and repeating the process from Step 1.
- The language can be changed at any time from the **⏏** setup menu. **⏏** “What to Do If You Can’t Read the Display” (P. 35)



- 4** Set the date, time, and date format.
- Use the <|> buttons on the arrow pad to highlight items.
 - Use the Δ ▽ buttons on the arrow pad to change the highlighted item.
 - The clock can be adjusted at any time from the ⏸ setup menu. ⏸ ⏸ Setup Menu > [⌚ Settings] (P. 176)
 - Press the Ⓞ button when settings are complete.

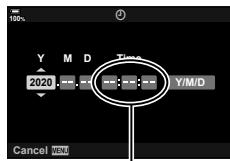

The time is displayed using a 24-hour clock.

- 5** Highlight a time zone using the Δ ▽ buttons and press the Ⓞ button.
- Press the **INFO** button to enable or disable daylight saving time.
- 6** Press the Ⓞ button to set the clock.
- If the battery is removed from the camera and the camera is left for a while, the date and time may be reset to the factory default setting.
 - You may also need to adjust the frame rate before shooting movies. ⏸ ⏸ Video Menu > [⏸ Specification Settings] > [⏸ ⏸] (P. 167)

What to Do If You Can't Read the Display

If you see unfamiliar characters or words in other languages, you may not have selected the language you intended. Follow the steps below to choose another language.

- 1 Press the **MENU** button to view the menus.

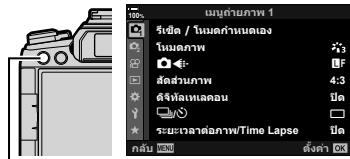

MENU button

- 2 Highlight the **Y** (setup) tab using $\Delta \nabla$ on the arrow pad and press the **OK** button.



- 3 Highlight [**English**] using the $\Delta \nabla$ buttons and press the **OK** button.

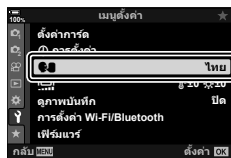

- 4 Highlight the desired language using the $\Delta \nabla \triangleleft \triangleright$ buttons and press the **OK** button.







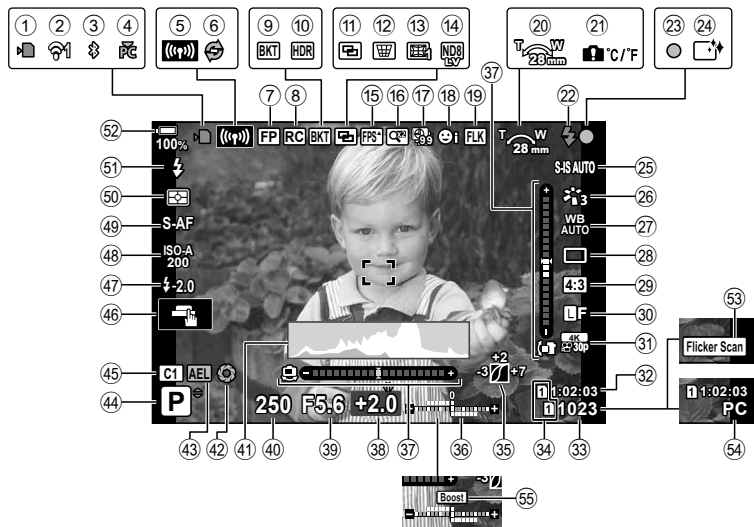

Information displays while shooting





Monitor display during still photography



Monitor display during movie mode



- ① Card write indicator.....P. 21, 27
- ② Wireless LAN connection statusP. 245, 256
- ③ Active **Bluetooth**® connectionP. 246
- ④ Active connection to computer (Wi-Fi)P. 256
- ⑤ Wireless LAN connection.....P. 247, 270
- ⑥ Pro Capture activeP. 81
- ⑦ Super FP flashP. 287
- ⑧ RC mode.....P. 288
- ⑨ Bracketing.....P. 146
- ⑩ HDR.....P. 152
- ⑪ Multiple exposure.....P. 154
- ⑫  Keystone compensationP. 156
- ⑬ Fisheye compensation.....P. 242
- ⑭ Live ND filter photographyP. 159
- ⑮ High frame rate.....P. 188
- ⑯ Digital Tele-converter.....P. 143
- ⑰ Time lapse shooting.....P. 144
- ⑱ Face priority/Eye priorityP. 92
- ⑲ Anti-flicker shootingP. 223
- ⑳ Zoom operation direction/Focal length
- ㉑ Internal temperature warning.....P. 300
- ㉒ Flash.....P. 84
(blinks: charging in progress, lights up: charging completed)
- ㉓ AF confirmation mark.....P. 42
- ㉔ Dust reduction.....P. 295
- ㉕ Image stabilizer.....P. 97
- ㉖ Picture mode.....P. 106, 142
- ㉗ White balanceP. 94
- ㉘ Drive mode (single-frame/sequential shooting/self-timer/vibration reduction/silent photography/Pro Capture/High Res Shot)P. 78–83, 98
- ㉙ Aspect ratio.....P. 98
- ㉚  Image qualityP. 100, 142
- ㉛  Image qualityP. 101
- ㉜ Available recording timeP. 317
- ㉝ Number of storable still pictures ...P. 316
- ㉞ Card slot settings
Top:  Save slot.....P. 237
Bottom:  Save settingsP. 99
- ㉟ Highlight & shadow controlP. 115
- ㊱ Top: Flash intensity controlP. 105
Bottom: Exposure compensation....P. 68
- ㊲ Level gaugeP. 40
- ㊳ Exposure compensation value.....P. 68
- ㊴ Aperture valueP. 44–50
- ㊵ Shutter speedP. 44–50
- ㊶ HistogramP. 39
- ㊷ PreviewP. 117
- ㊸ AE lock.....P. 77, 201
- ㊹ Shooting mode.....P. 41–60
- ㊺ Custom modeP. 57, 142
- ㊻ Touch operationP. 43
- ㊼ Flash intensity control.....P. 105
- ㊽ ISO sensitivityP. 75, 91
- ㊾ AF modeP. 64, 91
- ㊿ Metering mode.....P. 77
- ① Flash modeP. 86
- ② Battery level.....P. 32
- ③ Flicker scan.....P. 234
- ④ Active connection to computer (USB)P. 274
- ⑤ Live view boostP. 188
- ⑥ Audio recording level*P. 61, 169
- ⑦ Headphone volume*.....P. 61, 169
- ⑧ Recording level meter.....P. 169
- ⑨  View assist.....P. 164
- ⑩ Movie audio recordingP. 169
- ⑪  mode (movie exposure mode)P. 165
- ⑫ Recording time (displayed during recording).....P. 59
- ⑬ Time code.....P. 164
- ⑭ Silent control tab.....P. 61

* Displayed during adjustments to [ VOL] and [ VOL].  “Touch Controls (Silent Controls)” (P. 61) and [ Dial Function] (P. 163)

Switching between displays

The camera uses an eye sensor to automatically switch between the monitor and viewfinder displays. The monitor live view display and viewfinder also show information on camera settings. Options are available for controlling display switching and choosing the information shown.

Framing photos in the monitor

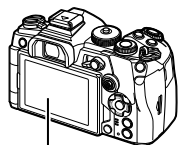

Monitor



Put your eye to the viewfinder



Framing photos in the viewfinder

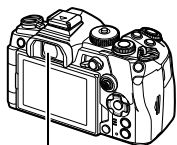

Viewfinder



Live view is displayed on the monitor.



The viewfinder turns on automatically when you bring it to your eye. When the viewfinder is lit up, the monitor turns off.

- If the viewfinder is not in focus, put your eye to the viewfinder and focus the display by rotating the diopter adjustment dial.
- Pressing the **LV** button switches the display in the monitor from live view to the super control panel. Putting your eye to viewfinder displays the view through the lens. The monitor turns off.
- Shooting information can be viewed by pressing the **INFO** button when the super control panel is displayed (P. 40).

Diopter adjustment dial

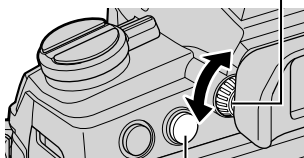

LV button



- Display switching and viewfinder display options are available in the menus.
INFO **⚙** Custom Menu **1** > [EVF Auto Switch] (P. 196), [EVF Style] (P. 240)

Switching the information display

You can switch the information displayed in the monitor during shooting using the **INFO** button.

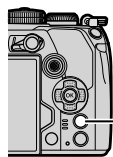

INFO button

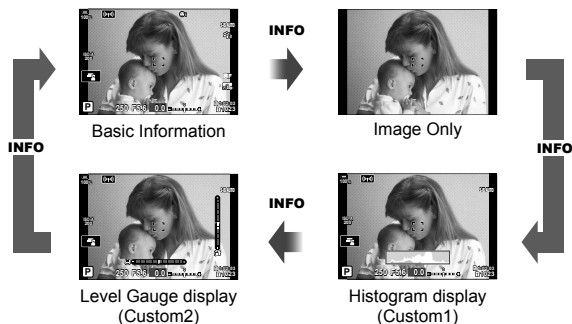

- The items shown in the Custom 1 and Custom 2 displays can be chosen using [Info/Custom Settings] > [LV-Info] (P. 227).
- The information shown in movie (MOV) mode can differ from that displayed in still photography mode. [Info/Video Menu] > [Info/Display Settings] > [Info/Info Settings] (P. 164)
- The information display screens can be switched in either direction by rotating the dial while pressing the **INFO** button.
- To choose the items displayed when the shutter button is pressed halfway, highlight [Image Only] in the [LV-Info] menu and press \blacktriangleright .

Histogram display

A histogram showing the distribution of brightness in the image is displayed. The horizontal axis gives the brightness, the vertical axis the number of pixels of each brightness in the image. Areas above the upper limit at shooting are displayed in red, those below the lower limit in blue, and those within the spot metering range in green. You can choose the upper and lower limits. [Info/Custom Menu] $\mathbf{D3}$ > [Histogram Settings] (P. 189)





Highlights and Shadows

Highlights and shadows, defined according to the upper and lower limits for the histogram display, are shown in red and blue. You can choose the upper and lower limits. [Info/Custom Menu] $\mathbf{D3}$ > [Histogram Settings] (P. 189)



Level gauge display

The orientation of the camera is indicated. The “tilt” direction is indicated on the vertical bar and the “horizon” direction on the horizontal bar.

- The level gauge is intended as a guide only.
- Calibrate the gauge if you find it is no longer truly plumb or level.   Custom Menu  > [Level Adjust] (P. 198)

Shooting Information

Shooting information can be viewed by pressing the **INFO** button when the super control panel (P. 88) is displayed. Press the **INFO** button again to return to the super control panel.

- Shooting information can be hidden using the [/Info Settings] > [LV OFF-Info] (P. 227) option in  Custom Menu .



Super control panel

INFO



Shooting information

Shooting still pictures

Use the mode dial to select the shooting mode, and then shoot the image.

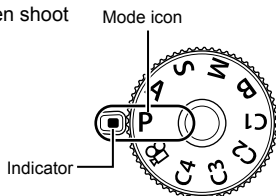

■ Types of shooting modes

For how to use the various shooting modes, see the following.

P	Program AE (P. 44)
A	Aperture-priority AE (P. 46)
S	Shutter-priority AE (P. 48)
M	Manual exposure (P. 50)
B	Bulb/time (P. 52)
	Live composite (P. 54)
C1/C2/C3/C4	Custom (P. 57)
	Movie (P. 60)

- 1 Press the mode dial lock to unlock it, and then turn to set the mode you wish to use.
 - When the mode dial lock has been pressed down, the mode dial is locked. Each time you press the mode dial lock, it switches between locked/released.

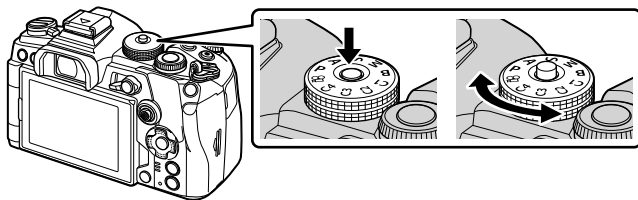

- 2 Frame the shot.

- Be careful that your fingers or the camera strap do not obstruct the lens or AF illuminator.

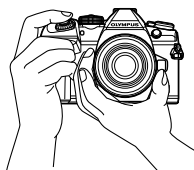

Landscape position

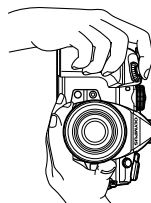

Portrait position

3 Adjust the focus.

- Lightly press the shutter button down to the first position (press the shutter button halfway).

The AF confirmation mark (●) will be displayed, and a green frame (AF target) will be displayed in the focus location.

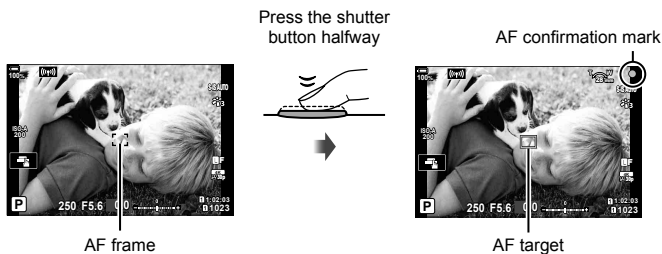

- If the camera is unable to focus, the AF confirmation mark will flash (P. 296).
- The AF frame varies with the option chosen for AF-target mode. The area covered by the AF target can be chosen in the AF-target selection display (P. 69). The AF frame is not displayed when (all targets) is chosen for AF-target mode.

4 Release the shutter.

- Press the shutter button all the way (fully).
 - The camera will release the shutter and take a picture.
- You can focus and take pictures using touch controls. "Shooting with touch screen operations" (P. 43)

Pressing the shutter button halfway and all the way down









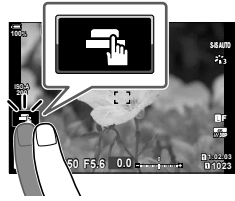

The shutter button has two positions. The act of lightly pressing the shutter button to the first position and holding it there is called "pressing the shutter button halfway", that of pressing it all the way down to the second position "pressing the shutter button all (or the rest of) the way down".



Shooting with touch screen operations

Tap  to cycle through touch screen settings.



-  Tap a subject to focus and automatically release the shutter. This option is not available in mode **B** (bulb), in  (movie) mode, or when /AF or  is selected for AF mode (P. 64).
-  Touch screen operations are disabled.
-  Tap to display an AF target and focus on the subject in the selected area. You can use the touch screen to choose the position and size of the focus frame. Photographs can be taken by pressing the shutter button.
-  Tap to choose the subject used for focus when multiple portrait subjects are detected.  is displayed when an option other than [Face Priority Off] is selected for [Face Priority] (P. 92, 183). Subject selection is not available when a frame rate of  (high-speed movie recording) is selected in  (movie) mode (P. 103).

■ Previewing the subject ()

1 Tap the subject in the display.

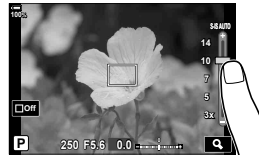

- An AF target will be displayed.
- Use the slider to choose the size of the frame.
- Tap  to turn off the display of the AF target.

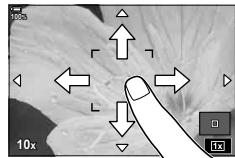

2 Use the slider to adjust the size of the AF target, and then tap to zoom in at the frame position.

- Use your finger to scroll the display when the picture is zoomed in.
- Tap  to cancel the zoom display.



- The situations in which touch screen operations are not available include the following.
 - In the one-touch capture white-balance display and when buttons or dials are in use
 - Do not touch the display with your fingernails or other sharp objects.
 - Gloves or monitor covers may interfere with touch screen operation.
 - You can disable the touch screen operation.   Custom Menu  > [Touchscreen Settings] (P. 198)

Letting the camera choose aperture and shutter speed

(P: Program AE)

The camera chooses the optimal aperture and shutter speed according to subject brightness.

- 1 Rotate the mode dial to **P**.

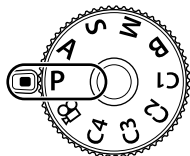

- 2 Focus and check the display.
 - The shutter speed and aperture chosen by the camera are displayed.
- 3 Take pictures.

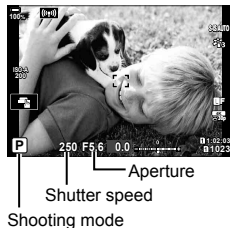

Subject Too Dark or Too Bright

If the camera is unable to achieve optimal exposure, the shutter-speed and aperture displays will flash as shown.

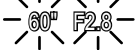
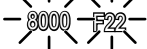
Display	Problem/solution
Large aperture (low f/-number)/ slow shutter speed 	The subject is too dark. <ul style="list-style-type: none"> • Use a flash.
Small aperture (high f/-number)/ fast shutter speed 	Subject is too bright. <ul style="list-style-type: none"> • The limits of the camera metering system have been exceeded. Use a third-party ND (Neutral Density) filter to reduce the amount of light entering the camera. • Shutter speeds as fast as 1/32000 s are available in [♥] (silent) mode. [🔇] “Shooting without shutter sound (Silent [♥])” (P. 81), “Performing the sequential/self-timer shooting” (P. 98)



- When using a fixed [📷 ISO] setting, change the setting. [🔍] “Changing ISO sensitivity (ISO)” (P. 75, 91)
- The aperture value shown when the displays flash varies with the lens and focal length.

■ Adjusting Settings in Mode P





Use the front and rear dials to adjust the following settings.

Front dial: Exposure compensation (P. 68)

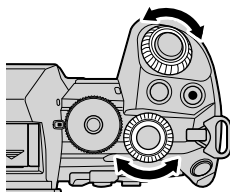
Rear dial: Program shift

- Exposure compensation can also be adjusted using the  button. Press the  button and then rotate the front or rear dial.



- You can choose the functions performed by the front and rear dials.   Custom Menu **B1** > [📷 Dial Function] (P. 218)
- You can use the **Fn** lever to reverse the roles of the front and rear dials. The lever can also be assigned other roles.   Custom Menu **B1** > [📷 Fn Lever Function] (P. 219)

■ Program Shift



Without changing exposure, you can choose from different combinations of aperture and shutter speed selected automatically by the camera. This is known as program shift.

- Rotate the rear dial until the camera displays the desired combination of aperture and shutter speed.
- The shooting mode indicator in the display changes from **P** to **Ps** while program shift is in effect. To end program shift, rotate the rear dial in the opposite direction until **Ps** is no longer displayed.



Program shift



- You can choose whether the display reflects the effects of exposure compensation or maintains a constant brightness for ease of viewing. At default settings, the effects of exposure settings are visible in the display.   Custom Menu **D2** > [Live View Boost] (P. 188)

Choosing aperture

(A: Aperture-Priority AE)

In this mode, you choose the aperture (f/-number) and the camera automatically sets the shutter speed for optimal exposure according to subject brightness. Lower aperture values (larger apertures) reduce the depth of the area that appears to be in focus (depth of field), blurring the background. Higher aperture values (smaller apertures) increase the depth of the area that appears to be in focus in front of and behind the subject.

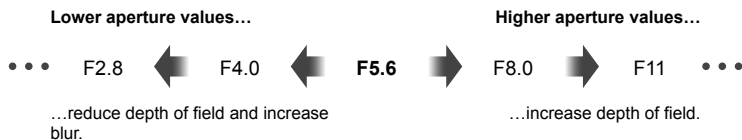

- 1 Rotate the mode dial to **A**.

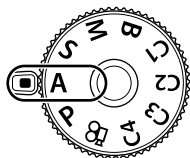

- 2 Choose an aperture.

- At default settings, aperture is selected by rotating the rear dial.
- The shutter speed selected automatically by the camera will appear in the display.



- 3 Take pictures.



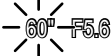
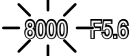

Aperture value

Subject Too Dark or Too Bright

If the camera is unable to achieve optimal exposure, the shutter-speed display will flash as shown.

Display	Problem/solution
Slow shutter speed 	Underexposure. • Choose a lower aperture value.
Fast shutter speed 	Overexposure. • Choose a higher aperture value. • If the subject is still overexposed at the higher value, the limits of the camera metering system have been exceeded. Use a third-party ND (Neutral Density) filter to reduce the amount of light entering the camera. • Shutter speeds as fast as 1/32000 s are available in [♥] (silent) mode.  "Shooting without shutter sound (Silent [♥])" (P. 81), "Performing the sequential/self-timer shooting" (P. 98)



- When using a fixed  ISO setting, change the setting.  "Changing ISO sensitivity (ISO)" (P. 75, 91)

■ Adjusting Settings in Mode A







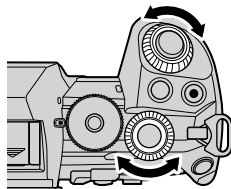

Use the front and rear dials to adjust the following settings.

Front dial: Exposure compensation (P. 68)

Rear dial: Aperture

- Exposure compensation can also be adjusted using the  button. Press the  button and then rotate the front or rear dial.



- You can choose the functions performed by the front and rear dials.   Custom Menu **B1** >  Dial Function] (P. 218)
- You can use the **Fn** lever to reverse the roles of the front and rear dials. The lever can also be assigned other roles.   Custom Menu **B1** >  Fn Lever Function] (P. 219)
- You can choose whether the display reflects the effects of exposure settings or maintains a constant brightness for ease of viewing. At default settings, the effects of exposure settings are visible in the display.   Custom Menu **D2** > [Live View Boost] (P. 188)
- You can stop aperture down to the selected value and preview depth of field.  "Assigning functions to buttons (Button Function)" (P. 116)

Choosing shutter speed

(S: Shutter-Priority AE)

In this mode, you choose the shutter speed and the camera automatically sets aperture for optimal exposure according to subject brightness. Faster shutter speeds appear to “freeze” fast-moving subjects. Slower shutter speeds add blur to moving objects, lending them a sense of motion for a dynamic effect.

Slower shutter speeds...

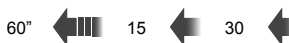

...produce dynamic shots with a sense of motion.

Faster shutter speeds...



...“freeze” the motion of fast-moving subjects.

1 Rotate the mode dial to S.

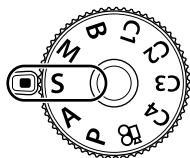

2 Choose a shutter speed.

- At default settings, shutter speed is selected by rotating the rear dial.
- Shutter speed can be set to values between 1/8000 and 60 s.
- Shutter speeds as fast as 1/32000 s are available in [♥] (silent) mode. [♥] “Shooting without shutter sound (Silent [♥])” (P. 81), “Performing the sequential/self-timer shooting” (P. 98)
- The aperture selected automatically by the camera will appear in the display.



Shutter speed

3 Take pictures.

Subject Too Dark or Too Bright

If the camera is unable to achieve optimal exposure, the aperture display will flash as shown.

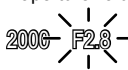
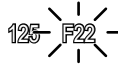
Display	Problem/solution
Low aperture value 	Underexposure. • Choose a slower shutter speed.
High aperture value 	Overexposure. • Choose a faster shutter speed. Shutter speeds as fast as 1/32000 s are available in silent mode. • If the subject is still overexposed at the higher speed, the limits of the camera metering system have been exceeded. Use a third-party ND (Neutral Density) filter to reduce the amount of light entering the camera.

- When using a fixed [📷 ISO] setting, change the setting. 🗨️ “Changing ISO sensitivity (ISO)” (P. 75, 91)
- The aperture value shown when the display flashes varies with the lens and focal length.

■ Adjusting Settings in Mode S

Use the front and rear dials to adjust the following settings.

Front dial: Exposure compensation (P. 68)

Rear dial: Shutter speed

- Exposure compensation can also be adjusted using the [📷] button. Press the [📷] button and then rotate the front or rear dial.

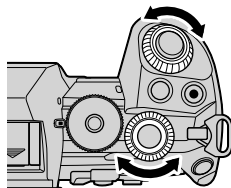

- You can choose the functions performed by the front and rear dials. 🗨️ ⚙️ Custom Menu [B1] > [📷 Dial Function] (P. 218)
- You can use the **Fn** lever to reverse the roles of the front and rear dials. The lever can also be assigned other roles. 🗨️ ⚙️ Custom Menu [B1] > [📷 Fn Lever Function] (P. 219)
- You can choose whether the display reflects the effects of exposure settings or maintains a constant brightness for ease of viewing. At default settings, the effects of exposure settings are visible in the display. 🗨️ ⚙️ Custom Menu [D2] > [Live View Boost] (P. 188)
- To achieve the effect of a slow shutter in brightly-lit settings in which slow shutter speeds are not otherwise available, use the live ND filter. 🗨️ 📷 Shooting Menu 2 > [Live ND Shooting] (P. 159)
- Depending on the shutter speed selected, you may notice banding in the display caused by flicker from fluorescent or LED light sources. The camera can be configured to reduce the effects of flicker during live view or when pictures are taken. 🗨️ ⚙️ Custom Menu [G1] > [Flicker Reduction] (P. 222), ⚙️ Custom Menu [E2] > [📷 Flicker Scan] (P. 234)

Choosing aperture and shutter speed (M: Manual Exposure)

In this mode, you choose the aperture and shutter speed. You can adjust settings according to your goals, for example by combining fast shutter speeds with small apertures (high *f*-numbers) for increased depth of field.

1 Rotate the mode dial to **M**.

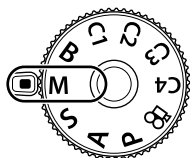

2 Adjust aperture and shutter speed.

- At default settings, aperture is selected with the front dial and shutter speed with the rear dial.
- Choose from shutter speeds of 1/8000–60 s.
- Shutter speeds as fast as 1/32000 s are available in silent mode. "Shooting without shutter sound (Silent [♥])" (P. 81)
- The display shows the difference between the exposure produced by the selected aperture and shutter speed and the optimal exposure metered by the camera. The display will flash if the difference exceeds ± 3 EV.
- When [AUTO] is selected for [ISO], ISO sensitivity will automatically be adjusted for optimal exposure at the selected exposure settings. [ISO] defaults to [AUTO]. "Changing ISO sensitivity (ISO)" (P. 75, 91)



Difference from optimal exposure

3 Take pictures.

Subject Too Dark or Too Bright

If the camera is unable to achieve optimal exposure with [AUTO] selected for [ISO], the ISO sensitivity display will flash as shown.

Display	Problem/solution
	Overexposure. <ul style="list-style-type: none"> • Choose a higher aperture value or faster shutter speed.
	Underexposure. <ul style="list-style-type: none"> • Choose a lower aperture value or slower shutter speed. • If the warning does not clear from the display, choose a higher value for ISO sensitivity. "Changing ISO sensitivity (ISO)" (P. 75, 91), Custom Menu > [ISO-Auto Set] (P. 191)

■ Adjusting Settings in Mode M

Use the front and rear dials to adjust the following settings.

Front dial: Aperture

Rear dial: Shutter speed

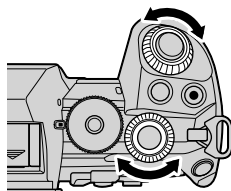

- You can choose the functions performed by the front and rear dials. Custom Menu **B1** > Dial Function] (P. 218)
- You can use the **Fn** lever to reverse the roles of the front and rear dials. The lever can also be assigned other roles. Custom Menu **B1** > Fn Lever Function] (P. 219)
- Depending on the shutter speed selected, you may notice banding in the display caused by flicker from fluorescent or LED light sources. The camera can be configured to reduce the effects of flicker during live view or when pictures are taken. Custom Menu **C1** > [Flicker Reduction] (P. 222), Custom Menu **E2** > Flicker Scan] (P. 234)
- You can choose whether the display reflects the effects of exposure settings or maintains a constant brightness for ease of viewing. At default settings, the display maintains a constant brightness for ease of viewing. Custom Menu **D2** > [Live View Boost] (P. 188)

■ Using Exposure Compensation in Mode M

In mode **M**, exposure compensation is available when [AUTO] is selected for ISO]. Because exposure compensation is performed by adjusting ISO sensitivity, aperture and shutter speed are not affected. "Changing ISO sensitivity (ISO)" (P. 75, 91), Custom Menu **E1** > ISO-Auto Set] (P. 191)

- Exposure compensation can be adjusted using the button. Hold the button and rotate the front or rear dial.
- Exposure compensation is added to the exposure difference shown in the display.



Exposure compensation

Exposure compensation plus exposure difference

Long Exposures

(B: Bulb/Time)

Select this mode to leave the shutter open for a long exposure. You can preview the photo in live view and end the exposure when the desired results have been achieved. Use when long exposures are required, for example when photographing night scenes or fireworks.

“Bulb” and “Live Bulb” Photography

The shutter remains open while the shutter button is pressed. Releasing the button ends the exposure.

- The amount of light entering the camera increases the longer the shutter is open.
- When live bulb photography is selected, you can choose how often the camera updates the live view display during the exposure.

“Time” and “Live Time” Photography

The exposure begins when the shutter button is pressed all the way down. To end the exposure, press the shutter button all the way down a second time.

- The amount of light entering the camera increases the longer the shutter is open.
- When live time photography is selected, you can choose how often the camera updates the live view display during the exposure.

1 Rotate the mode dial to **B**.

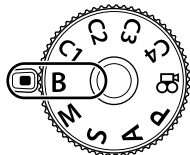

2 Select bulb or time photography.

- At default settings, the selection is made with the rear dial.

3 Press the **MENU** button.

- You will be prompted to choose the interval at which the preview is updated.



Bulb or time photography

4 Highlight an interval using Δ ∇ on the arrow pad.

5 Press the **OK** button to select the highlighted option.

- The menu will be displayed.

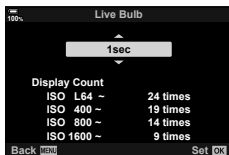

6 Press the **MENU** button to exit the menus.

- If an option other than [Off] is selected, [LIVE BULB] or [LIVE TIME] will appear in the display.

7 Adjust aperture.

- At default settings, aperture can be adjusted using the front dial.



Aperture

8 Take pictures.

- In bulb and live bulb modes, keep the shutter button pressed. The exposure ends when the button is released.
- In time and live time modes, press the shutter button all the way down once to start the exposure and again to end it.
- The exposure ends automatically when the time selected for [Bulb/Time Timer] is reached. The default is [8 min]. The time can be changed. Custom Menu **E2** > [Bulb/Time Timer] (P. 192)
- [Noise Reduct.] is applied after shooting. The display shows the time remaining until the process is complete. You can choose the conditions under which noise reduction is performed (P. 192).
- During live time photography, you can refresh the preview by pressing the shutter button halfway.
- Some limitations apply to the choice of ISO sensitivity settings available.
- Bulb photography is used in place of live bulb photography when multiple exposure, keystone compensation, or fisheye correction is in effect.
- Time photography is used in place of live time photography when multiple exposure, keystone compensation, or fisheye correction is in effect.
- During shooting, there are limits on the settings for the following functions.
 - Sequential shooting, self-timer shooting, time lapse shooting, AE bracket shooting, image stabilizer, flash bracketing, focus bracketing, multiple exposure, etc.
- Image Stabilizer] (P. 97) turns off automatically.
- Depending on camera settings, the temperature, and the situation, you may notice noise or bright spots in the monitor. These may sometimes appear in pictures even when [Noise Reduct.] (P. 192) is enabled.



- Starry sky AF can be used for shots of the night sky. "Choosing a focus mode (AF Mode)" (P. 64), Custom Menu **A4** > [Starry Sky AF Setting] (P. 184)
- Display brightness can be adjusted during bulb/time photography. At default settings, the display is darker than normal. Custom Menu **E2** > [Bulb/Time Monitor] (P. 192)
- During bulb/time photography, the brightness of the subject in the display is enhanced for ease of viewing when lighting is poor. You can choose whether to prioritize display quality or display speed. Custom Menu **D2** > [Live View Boost] (P. 188)
- In mode **B** (bulb), you can adjust focus manually while the exposure is in progress. This allows you to defocus during the exposure or focus at the end of the exposure. Custom Menu **A4** > [Bulb/Time Focusing] (P. 216)

Noise

While shooting at slow shutter speeds, noise may appear on screen. These phenomena occur when the temperature rises in the image pickup device or image pickup device internal drive circuit, causing current to be generated in those sections of the image pickup device that are not normally exposed to light. This can also occur when shooting with a high ISO setting in a high-temperature environment. To reduce this noise, the camera activates the noise reduction function.  * Custom Menu **B** > [Noise Reduct.] (P. 192)

Lighten Blending (B: Live Composite Photography)

Leave the shutter open for a long exposure. You can view the light trails left by fireworks or stars and photograph them without changing the exposure of the background. The camera combines multiple shots and records them as a single photograph.

1 Rotate the mode dial to **B**.

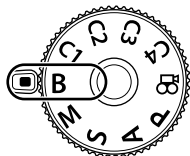

2 Select [LIVE COMP].

- At default settings, the selection is made with the rear dial.

3 Press the **MENU** button.

- The [Composite Settings] menu will be displayed.



Live composite photography

4 Highlight an exposure time using Δ ∇ on the arrow pad.

- Choose an exposure time of from 1/2 to 60 s.

5 Press the **OK** button to select the highlighted option.

- The menu will be displayed.



6 Press the **MENU** button repeatedly to exit the menus.

7 Adjust aperture.

- At default settings, aperture can be adjusted using the front dial.

8 Press the shutter button all the way down to ready the camera.

- The camera is ready to shoot when [Ready for composite shooting] is displayed.



9 Press the shutter button to start shooting.

- Live composite photography will start. The display will be updated after each exposure.

10 Press the shutter button again to end shooting.

- Shooting ends automatically after the time selected for [Live Composite Timer] (P. 192). The default is [3h]. Other options can be selected.
- The maximum recording time available varies with battery level and shooting conditions. For long recording times, use an optional power battery holder (P. 24) and AC adapter (P. 25).
- Some limitations apply to the choice of ISO sensitivity settings available.
- Limitations apply to some features during shooting, including:
 - sequential shooting, the self-timer, interval timer photography, AE bracketing, flash bracketing, focus bracketing, High Res Shot, HDR photography, multiple exposure, keystone compensation, the live ND filter, and fisheye correction.
- [Image Stabilizer] (P. 97) turns off automatically.



- Starry sky AF can be used for shots of the night sky. “Choosing a focus mode (AF Mode)” (P. 64), Custom Menu **A4** > [Starry Sky AF Setting] (P. 184)
- Display brightness can be adjusted during live composite photography. At default settings, the display is darker than normal. Custom Menu **2** > [Bulb/Time Monitor] (P. 192)
- The exposure time for each exposure made during live composite photography can be chosen in advance using the menus. Custom Menu **2** > [Composite Settings] (P. 233)

Saving Custom Settings to the Mode Dial (C1/C2/C3/C4 Custom Modes)

Frequently-used settings and shooting modes can be saved as custom modes and recalled as needed simply by rotating the mode dial. Saved settings can also be recalled directly from the menus.

- Save settings to positions **C1** through **C4**.
- At default settings, custom modes are equivalent to mode **P**.

Saving Settings (Assign to Custom Mode)

- 1 Choose a mode other than **P** and adjust settings as desired.
 - For information on the settings that can be saved, see the menu list (P. 301).
- 2 Press the **MENU** button to display the menus.
- 3 Highlight [Reset / Custom Modes] in **Shooting Menu 1** and press **▶** on the arrow pad.
 - [Reset / Custom Modes] options will be displayed.
- 4 Highlight [Assign to Custom Mode] using the **Δ** **▽** buttons and press the **▶** button.
 - [Assign to Custom Mode] options will be displayed.
- 5 Highlight the desired custom mode ([Custom Mode C1]–[Custom Mode C4]) using **Δ** **▽** buttons and press the **▶** button.
 - The menu for the selected custom mode will be displayed.

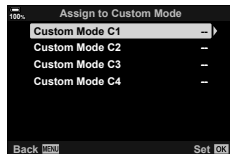
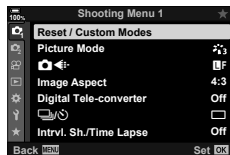
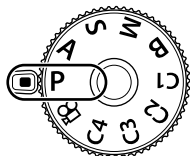

6 Highlight [Set] using the Δ ∇ buttons and press the \odot button.

- The [Assign to Custom Mode] menu will be displayed again.
- Any existing settings will be overwritten.
- To restore default settings for the selected custom mode, highlight [Reset] and press the \odot button.

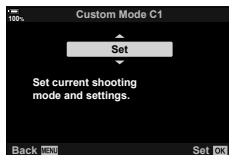

7 Press the **MENU** button repeatedly to exit the menus.



- Custom modes can be updated automatically to reflect any changes made to settings while the mode is selected during shooting.

Using Custom Modes (C1/C2/C3/C4)

To recall all saved settings, including the shooting mode:

1 Rotate the mode dial to the desired custom mode (**C1**, **C2**, **C3**, or **C4**).

- The camera will be set to the settings for the selected mode.

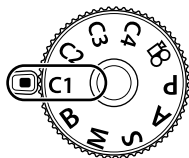

2 Take pictures.

- By default, changes made after recall will not be applied to the stored settings. The saved settings will be restored when next you select the custom mode with the mode dial.
- If [Hold] is selected for [Custom Mode Save Settings], custom modes will be updated automatically to reflect any changes made to settings while the mode is selected during shooting. The changes will remain stored in the custom mode even after the mode dial is rotated to another setting. Custom modes can be used in much the same way as modes **P**, **A**, **S**, **B**, and **M**.













■ Updating Custom Modes Automatically

Custom modes can be updated automatically to reflect any changes made to settings while the mode is selected during shooting.

- 1** Highlight [Reset/Custom Modes] in \mathbf{M} Shooting Menu 1 and press the \odot button.
- 2** Highlight [Custom Mode Save Settings] and press \triangleright on the arrow pad.
- 3** Highlight a custom mode ([Custom Mode C1]–[Custom Mode C4]) and press the \odot button.
- 4** Highlight [Hold] and press the \odot button.

■ Recalling Saved Settings

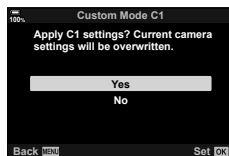
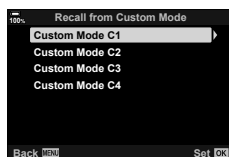
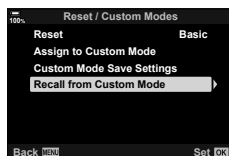
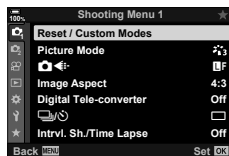

In modes other than , you can recall the settings stored in custom modes [Custom Mode C1] through [Custom Mode C4] but not the shooting mode. The shooting mode remains that currently selected with the mode dial.

- 1 Press the **MENU** button to display the menus.
- 2 Highlight [Reset / Custom Modes] in  Shooting Menu 1 and press  on the arrow pad.
 - [Reset / Custom Modes] options will be displayed.
- 3 Highlight [Recall from Custom Mode] using the   buttons and press the  button.
 - The [Recall from Custom Mode] menu will be displayed.
- 4 Highlight the desired custom mode using the   buttons and press the  button.
- 5 Highlight [Yes] using the   buttons and press the  button.
 -  Shooting Menu 1 will be displayed.





- 6 Press the **MENU** button to exit the menus.



- [ Button Function] (P. 116) can be used to assign custom modes [Custom Mode C1] through [Custom Mode C4] (P. 119) to a camera control, allowing the stored settings to be recalled at the touch of a button in all modes except . The selected shooting mode is also recalled. Press the control to turn the custom mode on or off.
- Settings recalled by pressing a button cease to apply when you:
 - Turn the camera off
 - Rotate the mode dial to another setting
 - Press the **MENU** button during shooting
 - Perform a reset
 - Save or recall custom settings

Recording Movies

Recording movies in photo shooting modes

The  button can be used for movie recording even when the mode dial is not in the  position.



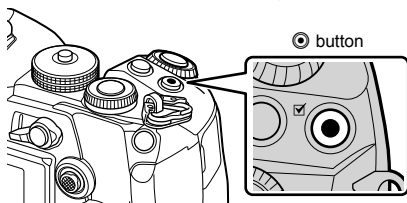

1 Press the button to begin recording.



- Movie you are recording will be displayed on the monitor.
- If you put your eye to the viewfinder, movie you are recording will be displayed in the viewfinder.
- You can change the focus location by tapping the screen while recording.
- The camera will start the recording count and display the recording time.



Recording time

2 Press the button again to end recording.

- The sound of touch operations and button operations may be recorded.
- The AF target takes on the shape selected for movie mode. Rotate the mode dial to  (movie mode) and choose target shape in the AF target selection display (P. 69).
- The situations in which touch screen operations are not available include the following.
In the one-touch capture white-balance display and when buttons or dials are in use
- CMOS image sensors of the type used in the camera generate a so-called “rolling shutter” effect that can cause distortion in pictures of moving objects. This distortion is a phenomenon that occurs in pictures of fast-moving subjects or if the camera is moved during shooting. It is particularly noticeable in pictures taken at long focal lengths.
- Movies over 4 GB in size are recorded over multiple files (depending on shooting conditions, the camera may start recording to a new file before the 4 GB limit is reached). The files can be played back as a single movie.  “Viewing Movies over 4 GB in Size” (P. 130)
- When recording movies, use an SD card that supports an SD speed class of 10 or higher.
- A UHS-II or UHS-I card with a UHS speed class of 3 or better is required when:
a movie resolution of [4K] or [C4K] is selected in the  menu or a bit rate of [A-I] (All-Intra) is selected in the  menu
- When the camera is used continuously for extended periods, the temperature of the image sensor will rise and noise and color splotches may be visible in the display. Should this occur, turn the camera off and wait for it to cool. Noise and color splotches are particularly likely to occur at high ISO sensitivities. If the temperature of the sensor increases further, the camera will turn off automatically.

- When using a Four Thirds system lens, the AF will not operate while recording movies.
- The  button cannot be used to record movies in the following instances:
 - During a multiple exposure (still photography also ends), while the shutter button is pressed halfway, in mode **B**, during sequential shooting, time-lapse photography, keystone compensation, or fish-eye correction, or while the live ND filter is in use
- When high-speed movie recording is selected for [ ←], movies shot with [i-Enhance], [e-Portrait], or an art filter selected for picture mode will be recorded in [Natural] mode.



- Some settings, such as AF mode, can be set separately for movies and photographs.
 “Using the Video Menu” (P. 161)

Recording movies in movie mode ()

Rotate the mode dial to  (movie mode) to record movies using the effects available in **P**, **A**, **S**, and **M** modes (P. 165).

- Configuring the shutter button so that it can be used to record movies requires changes to [ Shutter Function] (P. 163).
- A beep does not sound when the camera focuses in movie mode.

Touch Controls

(Silent Controls)

You can prevent the camera from recording operating sounds that occur due to camera operations while shooting. Tap the silent shooting tab to display the function items. After tapping an item, tap the displayed arrows to select the settings.

Silent control tab







W/↓ (power zoom)	Zoom power zoom lenses in or out.
🎧 (headphone volume)	Adjust volume when using headphones.
🎤 (recording level)	Choose the recording level.
SS (shutter speed)	Adjust shutter speed when [S] (shutter-priority AE) or [M] (manual) is selected for [🎥 Mode] (movie exposure mode) (P. 165).
FNo (aperture)	Adjust aperture when [A] (aperture-priority AE) or [M] (manual) is selected for [🎥 Mode] (movie exposure mode) (P. 165).
☑ (exposure compensation)	Adjust exposure compensation. If [M] is selected for [🎥 Mode] (movie exposure mode) (P. 165), exposure compensation is available when [AUTO] is selected for [🎥 ISO] (P. 75).
ISO (🎥 ISO sensitivity)	Adjust [🎥 ISO] (P. 75). This option is available when [M] is selected for [🎥 Mode] (movie exposure mode) (P. 165).

- Silent controls are not available during high-speed movie recording (P. 103).

Shooting Settings

The camera offers many photography-related functions. Depending on how often you use them, you can access settings via buttons, icons in the display, or menus that can be used for detailed adjustments.

Method	Description	
Direct buttons	Adjust settings directly using buttons, including those listed below. Commonly-used functions are assigned to buttons for quick access during viewfinder photography. <ul style="list-style-type: none">• The , , , and ISO buttons	63
LV super control panel/ super control panel	Choose from a list of settings showing current camera status. You can also view current camera settings.	88
Live controls	Adjust settings while viewing your subject in the display.	225
Menus	Adjust settings from menus displayed in the monitor.	139

Direct Buttons

Frequently-used photographic functions are assigned to buttons. These are referred to as “direct buttons”. Included are the buttons listed below, which can be used for basic shooting settings.

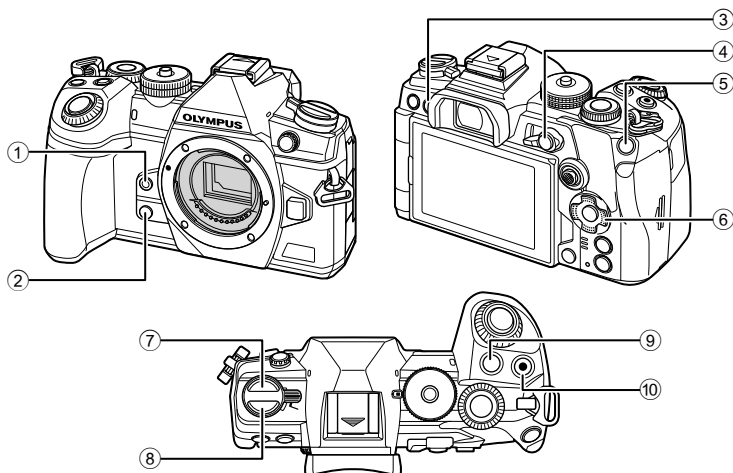

Direct button	Assigned function
① button	One-touch white balance (P. 95)
② button	Preview (P. 117)
③ (LV) button	Display (monitor/viewfinder) selection (P. 38)
④ AEL/AFL button	AEL/AFL (P. 77)
⑤ ISO button	ISO sensitivity (P. 75)
⑥ Arrow pad	[::] (AF-target position) (P. 69)
⑦ button	Sequential/self-timer shooting (P. 78, 86)
⑧ AF button	AF/metering mode (P. 64, 77)
⑨ button	Exposure compensation (P. 68)
⑩ button	Movie recording (P. 59)



- Buttons can be assigned different roles. “Assigning functions to buttons (Button Function)” (P. 116)

Choosing a focus mode



(AF Mode)

You can select a focusing method (focus mode).

- 1 Press the **AF**  button.
- 2 Rotate the rear dial to select an option.
- 3 Press the shutter button halfway to exit to the shooting display.



AF Mode

S-AF (Single AF)	<p>The camera focuses once when the shutter button is pressed halfway. When the focus is locked, a beep sounds, and the AF confirmation mark and the AF target mark light up. This mode is suitable for taking pictures of still subjects or subjects with limited movement.</p>
C-AF (Continuous AF)	<p>The camera repeats focusing while the shutter button remains pressed halfway. When the subject is in focus, the AF confirmation mark lights up on the monitor and the beep sounds when the focus is locked at the first time. Even if the subject moves or you change the composition of the picture, the camera continues trying to focus.</p>
MF (Manual focus)	<p>This function allows you to manually focus on any position by operating the focus ring on the lens.</p> <div style="text-align: right;">  <p>Focus ring</p> </div>
C-AF+TR (AF tracking)	<p>Press the shutter button halfway to focus; the camera then tracks and maintains focus on the current subject while the shutter button is held in this position.</p> <ul style="list-style-type: none"> • The AF target is displayed in red if the camera can no longer track the subject. Release the shutter button and then frame the subject again and press the shutter button halfway. • Autofocus does not work while the AF target is displayed in red even if the camera is tracking the subject. • Tracking AF cannot be used with: keystone compensation, High Res Shot, focus stacking, focus bracketing, interval-timer photography, HDR photography, the live ND filter, or fisheye correction.
PreMF (Preset MF)	<p>The camera automatically focuses on the preset focus point when shooting.</p>
 Starry Sky AF (Starry Sky AF)	<p>Choose this mode for pictures of stars in the night sky. Press the AEL/AFL button to focus on the stars.  "Using Starry Sky AF" (P. 66)</p>

- The camera may be unable to focus if the subject is poorly lit, obscured by mist or smoke, or lacks contrast.
- When using a Four Thirds system lens, AF will not be available during movie recording.

- [AF Mode] selection is not available when the lens focus ring is in the MF position and [Operative] is selected for [MF Clutch] (P. 184) in **★ Custom Menu A4** (P. 286).
- The **Fn** lever can be used to choose between the [AF Mode] settings assigned to **Fn** lever Positions 1 and 2. **☞** **★ Custom Menu B1** > [**📷 Fn Lever Function**] (P. 185, 219), **📷 Video Menu** > [**📷 Button/Dial/Lever**] > [**📷 Fn Lever Function**] (P. 163)

Adjusting Focus Manually During Autofocus

- Before proceeding, select [On] for [**📷 AF+MF**] (P. 200) in **★ Custom Menu A1**. **MF** will be displayed in [S-AF], [C-AF], [C-AF+TR], and [**📷 AF MF**] modes.
- 1 Choose a focus mode marked with an **MF** icon (P. 64).
 - When recording movies, choose [S-AF **MF**] for [**📷 AF Mode**] (P. 162).
 - 2 Press the shutter button halfway to focus using autofocus.
 - In [**📷 AF MF**] mode, press the **AEL/AFL** button to initiate starry sky AF.
 - 3 Keeping the shutter button pressed halfway, rotate the focus ring to adjust focus manually.
 - To refocus using autofocus, release the shutter button and press it halfway again.
 - Manual focus adjustment during autofocus is not available in [**📷 AF MF**] mode.
 - Manual focus adjustment during autofocus is available via the focus ring on M.ZUIKO PRO (Micro Four Thirds PRO) lenses. For information on other lenses, see the OLYMPUS website.
 - 4 Press the shutter button the rest of the way down to take the picture.

Using Starry Sky AF

- 1 Select [**A**]AF for AF mode and press the **OK** button.
- 2 Press the **AEL/AFL** button to initiate starry sky AF.
 - To interrupt starry sky AF, press the **AEL/AFL** button again.
 - At default settings, starry sky AF does not start when the shutter button is pressed halfway. To configure the camera so that starry sky AF does start when the shutter button is pressed halfway, use [**A**]AEL/AFL (P. 201) in **Custom Menu A1**.
 - The camera displays [Starry Sky AF is Running] during starry sky AF. The in-focus indicator (●) is displayed for about two seconds after the camera focuses; if the camera is unable to focus, the in-focus indicator will instead flash for about two seconds.
- 3 Press the shutter button all the way down to take the picture.



- The [Starry Sky AF Setting] (P. 184) item in **Custom Menu A4** offers a choice of [Accuracy] and [Speed]. Mount the camera on a tripod before taking photographs with [Accuracy] selected.
- Your choice of AF-target modes (P. 69) is restricted to single target, 9-target group (3×3), and 25-target group (5×5).
- The camera will not be able to focus in bright locations.
- Starry sky AF cannot be used with Pro Capture.
- [**A**]Orientation Linked [**A**] (P. 210), [**A**]Loop Settings] (P. 208), [AF Limiter] (P. 211), and [AF Illuminator] (P. 183) are fixed at [Off], [Face Priority] (P. 92) at [Face Priority Off], [Frame Rate] (P. 188) at [Normal], and [AF Scanner] (P. 181) at [mode1].
- The camera automatically focuses at infinity when starry sky AF is selected.
- When [On] is selected for [S-AF Release Priority] (P. 186) in **Custom Menu C1**, the shutter can be released even when the subject is not in focus.
- Manual focus is selected when a Four Thirds lens is attached.
- Starry sky AF is available with OLYMPUS Four Thirds lenses. It cannot, however, be used with lenses with a maximum aperture over f/5.6. For more information, visit the OLYMPUS website.

Setting a focus position for PreMF

- 1 Select [PreMF] for AF mode, and press **INFO** button.
- 2 Press the shutter button halfway to focus.
 - Focus can be adjusted by rotating the focus ring.
- 3 Press the **OK** button.
 - The PreMF function can be recalled by pressing the button to which [Preset MF] is assigned in [Button Function] (P. 116). Press the button again to return to the original AF.
 - The distance for the preset focus point can be set with [Preset MF distance] in **Custom Menu A4** (P. 184).
 - The camera also focuses at the preset distance:
 - when turned on and
 - when you exit the menus to the shooting display.



Manual Focus Adjustment

When [S-AF **MF**], [C-AF **MF**], [MF], [C-AF+TR **MF**], [PreMF], or [**AF** **MF**] is selected for AF mode, focus can be adjusted manually during exposures or while pictures are being taken in [Sequential Low] mode.



- In mode **B** (bulb), manual focus adjustment can be performed according to the option selected for [Bulb/Time Focusing] (P. 216).

Controlling exposure (Exposure Compensation)

The exposure selected automatically by the camera can be altered to suit your artistic intent. Choose positive values to make pictures brighter, negative values to make them darker.

- Exposure compensation is available in modes **P**, **A**, **S**, and . To enable exposure compensation in mode **M**, select [AUTO] for  ISO (P. 75).



- Exposure compensation can be adjusted by up to ± 5.0 EV. The exposure bar in the display shows values of up to ± 3.0 EV. The bar flashes when a value outside this range is selected.
- During movie recording, exposure compensation can be adjusted by ± 3.0 EV.
- The viewfinder and live view show the effects of values not exceeding ± 3.0 EV.
- To preview the effects of exposure compensation in live view, select [Off] for [Live View Boost] (P. 188) in  Custom Menu .
- The front and rear dials or touch controls can be used to adjust exposure during movie recording.







Exposure compensation bar

■ Adjusting Exposure Compensation







Modes P, A, and S

- In movie mode, exposure compensation can be adjusted when [P], [A], or [S] is selected for  Mode (movie exposure mode).

- Rotate the front dial to adjust exposure compensation.
 - You can also choose a value by pressing the  button and using   on the arrow pad.
 - To reset exposure compensation, press the .

- Take pictures.

Mode M

- In movie mode, exposure compensation can be adjusted when [M] is selected for  Mode (movie exposure mode). You must first however select [On] for  Video Menu >  Specification Settings >  ISO-M ISO-Auto Set >  ISO-M ISO-Auto (P. 161) and [AUTO] for  ISO (P. 75).

- Press the  button and then rotate the front dial or rear dial to adjust exposure compensation.
- Take pictures.



- (exposure compensation) can be assigned to other controls. “Assigning functions to buttons (Button Function)” (P. 116)

Choosing an AF Target Mode (AF Target Mode)

- 1 Keep the multi selector pressed while rotating the front or rear dial.

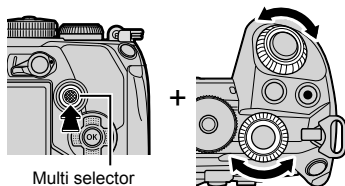

- The camera cycles through AF target modes as shown.

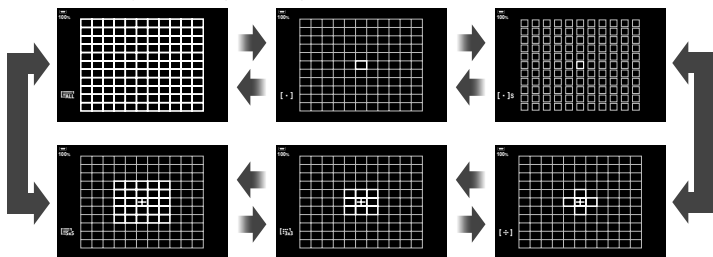

- At default settings, custom target modes (P. 71) are not displayed. Display can be enabled by going to Mode Settings] (P. 182) in Custom Menu placing checks (✓) next to the desired options.

- 2 Release the multi selector when the desired mode is displayed.

- AF target mode options will no longer be displayed.
- The following reduce the number of AF targets available:
 - Selecting [On] for [Digital Tele-converter] (P. 143)
 - Selecting an option other than [4:3] for [Aspect] (P. 98)



- Settings can also be adjusted by first pressing a button and then using the front or rear dial. Access the AF-target display by pressing the control to which has been assigned via [Button Function] (P. 116). You can then adjust settings by rotating the front or rear dial. At default settings, is assigned to the arrow pad.
- The AF target display can be accessed by pressing the multi selector. The multi selector can be configured using [Center Button] (P. 217) in Custom Menu .
- Separate AF target modes can be selected according to camera orientation.
 - Custom Menu > Orientation Linked (P. 210)

- The following focus settings can be recalled simultaneously using the **Fn** lever. Separate settings can be assigned to Positions 1 and 2. Use this option to quickly adjust settings according to shooting conditions.

[AF Mode] (P. 64), [AF Target Mode] (P. 69), and [AF Target Point] (P. 72)

The **Fn** lever can be configured using the [Fn Lever Function] item (P. 219) in

Custom Menu **B1** or the [Fn Button/Dial/Lever] > [Fn Lever Function] item (P. 163) in the video menu.

- You can adjust AF target settings for [C-AF], [Custom Menu **A1**] > [C-AF Center Start] (P. 204) and [C-AF Center Priority] (P. 205)
- Separate options can be selected for still photography and movie mode.

■ AF Target Modes

- The only options available when **AF** is selected are single target, 9-target group (3 × 3), and 25-target group (5 × 5) modes.
- The only options available during movie recording are single target, 9-target group (3 × 3), 25-target group (5 × 5), and all target (11 × 9) modes.

[·] Single Target

Select a single focus target.

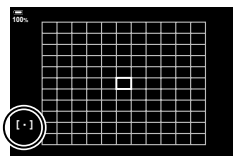

[·]s Small Target

Further reduce the target size for single-target AF-target selection. Use for pinpoint focus on small subjects.

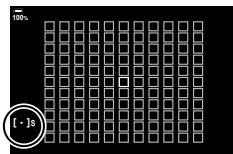

[·:] 5-Target Group

Select a group of 5 targets, arranged in a cross. The camera chooses the target used for focus from within the selected group.

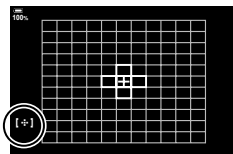

[::] 9-Target Group (3 × 3)

Select a group of 9 targets, arranged in a square. The camera chooses the target used for focus from within the selected group.

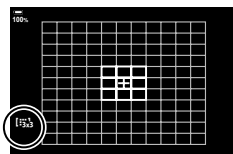

25-Target Group (5 × 5)

Select a group of 25 targets, arranged in a square. The camera chooses the target used for focus from within the selected group.

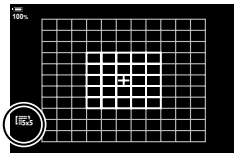

All Targets

The camera chooses the target used for focus from all available targets.

- The camera chooses from 121 (11 × 11) targets during still photography and from 99 (11 × 9) targets in movie mode.

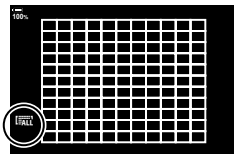

Custom Target

Custom target modes can be displayed by going to [Mode Settings] (P. 182) in

- ⚙ Custom Menu **A2** and placing checks (✓) next to the desired options. Use the AF target mode selected for [Target Mode Settings] (P. 209) in
- ⚙ Custom Menu **A2**. The default setting is single target.



- To enable cluster AF targeting when  (all targets) is selected and either [C-AF] is chosen for [AF Mode] or [S-AF], [S-AF **MF**], [C-AF], or [C-AF **MF**] is chosen for [AF Mode] (P. 64), select [On2] for [AF Area Pointer] (P. 182). The camera will display AF targets for all areas that are in focus.



Choosing a Focus Target

(AF Target Point)

The frame showing the location of the focus point is referred to as the "AF target". You can position the target over your subject. At default settings, the multi selector is used to position the AF target.

- 1 Use the multi selector to position the AF target.
 - The target can also be positioned using the arrow pad. Pressing Δ ∇ \triangleleft \triangleright buttons displays the AF target.

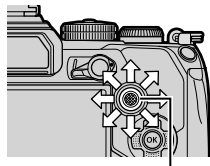

Multi selector

- The AF target is displayed at the start of the operation.
- To select the center AF target, press the multi selector or press and hold the \odot button.
- You can choose whether AF-target selection "wraps around" the edges of the display (P. 208).



AF target

2 Take pictures.

- The AF-target selection display will clear from the monitor when the shutter button is pressed halfway.
- The AF frame is displayed in place of the selected AF target.
- If [\cdot ; \cdot ; \cdot] is assigned to a control using [Button Function] (P. 116), you can press the control and then use the arrow pad or multi selector to choose the AF target.
- You can reposition the AF target during focusing when [C-AF] or [C-AF **MF**] is selected in still photography mode.
- You can also reposition the AF target during movie recording.
- The size and number of the AF target changes depending on the [Digital Tele-converter] (P. 143), [Aspect] (P. 98), and group target (P. 69) settings.



- When [On] is selected for [AF Targeting Pad] (P. 183), you can reposition the AF target using monitor touch controls while framing your subject in the viewfinder.

You can zoom in on the display during shooting. For greater precision during focusing, zoom in on the focus area. At higher zoom ratios, you can focus on areas smaller than the standard focus target. You can reposition the focus area as desired during zoom.

- Before you will be able to use Super Spot AF, you must use [Button Function] (P. 116) to assign [Q] (P. 119) to a camera control.

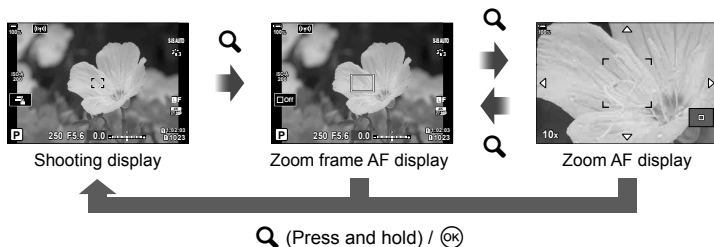

1 Press the button to which [Q] (magnify) is assigned.

- The zoom frame will be displayed.

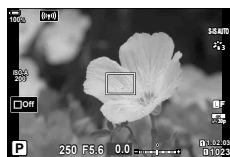

2 Position the frame using the multi selector.

- To re-center the frame, press the multi selector or press and hold the OK button.
- The frame can also be positioned using the arrow pad ($\Delta \nabla \triangleleft \triangleright$).

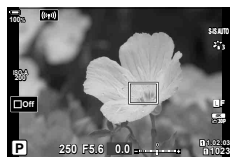

3 Adjust the size of the zoom frame to choose the zoom ratio.

- Press the **INFO** button and then use the $\Delta \nabla$ buttons or the front or rear dial to adjust the size of the zoom frame.
- Press the OK button to accept and exit.



4 Press the button to which [Q] is assigned once more.

- The camera will zoom the selected area in to fill the display.
- Use the front or rear dial to zoom in or out.
- Use the multi selector to scroll the display.
- Use the arrow pad (△ ▽ ◀ ▶) to scroll the display.
- In shooting mode **M** (manual) or **B** (bulb), you can press the **INFO** button during zoom to choose aperture or shutter speed.
- Press the **Q** button to return to the zoom frame.
- Press the **OK** button to end focus zoom.
- You can also end focus zoom by pressing and holding the **Q** button.



Exposure adjustment display for modes **M** and **B**

5 Press the shutter button halfway to focus using autofocus.

- Focus zoom applies to the display only. Pictures taken with the camera are not affected.



- Touch controls can be used for focus zoom.  "Shooting with touch screen operations" (P. 43)
- You can make the area in the zoom frame brighter for easier focus or configure the camera to exit focus zoom when the shutter button is pressed halfway to focus.   Custom Menu **D2** > [LV Close Up Settings] (P. 188)

Select a value according to subject brightness. Higher values let you photograph darker scenes but also increase image “noise” (mottling). Select [AUTO] to let the camera adjust sensitivity according to lighting conditions.

- ISO sensitivity is fixed at [AUTO] during movie recording when [P], [A], or [S] is selected for [Mode] (movie exposure mode). Setting [Mode] to [M] allows other options to be selected.

1 Press the **ISO** button, and rotate the front or rear dial to select a value.

<p>AUTO</p>	<p>Sensitivity is adjusted automatically according to shooting conditions. Use [ISO-Auto Set] (P. 191) in Custom Menu 5 to choose the maximum sensitivity selected by the camera and the shutter speed at which auto sensitivity control takes effect during still photography.</p> <p>During movie recording, ISO sensitivity will be set to values of from ISO 200 to 6400. When [M] is selected for [Mode] (movie exposure mode), auto ISO sensitivity control can be enabled by selecting [On] for [ISO-Auto Set] (P. 161) > [ISO-Auto]. You can also choose maximum and standard values for ISO sensitivity.</p>
<p>L64, L100, 200–25600 (still photography)</p>	<p>Choose a value for ISO sensitivity. ISO 200 offers a good balance between noise and dynamic range. Choose [L100] or [L64] for larger apertures (higher f-numbers) or slower shutter speeds. [L64] is equivalent to ISO 64, [L100] to ISO 100.</p> <ul style="list-style-type: none"> [L64] and [L100] are available at all exposure step values. [L64] and [L100] reduce dynamic range.
<p>200–6400 (movie recording)</p>	<p>Choose a value for [ISO]. ISO 200 offers a good balance between noise and dynamic range. This option is available when [M] is selected for [Mode] (movie exposure mode).</p>

- Combining values over ISO 8000 with settings that use an electronic shutter (for example, silent mode or focus bracketing) sets the flash sync speed to 1/20 s.
- Regardless of the value selected for ISO sensitivity, the flash sync speed for photos taken using ISO bracketing in silent mode is 1/20 s.
- When [M] is selected for [Mode] (movie exposure mode), ISO sensitivity can be adjusted during recording using touch controls (P. 61) or by rotating the front or rear dial.
- If [Dramatic Tone] or [Watercolor] is chosen for picture mode during still photography, sensitivity will not exceed ISO 1600 when [AUTO] is selected.

- The following restrictions apply when [M] is selected for [Movie Mode] (movie exposure mode):
 - [OM-Log400] selected for picture mode:
 - If the frame rate selected for [Frame Rate] is 24p, 25p, or 30p, [AUTO] is restricted to sensitivities of ISO 400–3200.
 - If the frame rate selected for [Frame Rate] is 50p or 60p, [AUTO] is restricted to sensitivities of ISO 400–6400.
 - The lowest value that can be selected manually is ISO 400.
 - Other picture modes:
 - If the frame rate selected for [Frame Rate] is 24p, 25p, or 30p, [AUTO] is restricted to sensitivities of ISO 200–3200.



- The role performed by the ISO button can also be assigned to other controls.
 - “Assigning functions to buttons (Button Function)” (P. 116)

Choosing how the camera measures brightness (Metering)

You can choose how the camera meters subject brightness.

- 1 Press the **AF** button.
- 2 Rotate the front dial to select an option.
- 3 Press the shutter button halfway to exit to the shooting display.

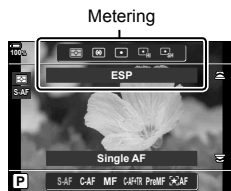

Digital ESP metering	Suited to most scenes, including back-lit subjects. The camera meters 324 areas of the frame and calculates optimal exposure taking into consideration the nature of the scene.	
Center weighted averaging metering	Suited to compositions that place the main subject at the center of the frame. The camera sets exposure based on the average light level for the entire frame while assigning the greatest weight to the area in the center.	
Spot metering	Use a specific area of the subject meter exposure. The camera meters a small portion (approximately 2%) of the frame.	
Spot metering (highlight)	Increases spot metering exposure. Ensures bright subjects appear bright.	
Spot metering (shadow)	Lowers spot metering exposure. Ensures dark subjects appear dark.	

- The spot metering position can be set at the selected AF target. Custom Menu > [[:]] Spot Metering (P. 193)

Locking the exposure (AE Lock)

You can lock the exposure by pressing the **AEL/AFL** button. Use this when you want to adjust the focus and exposure separately or when you want to shoot several images at the same exposure.













AE lock is available only when [mode1] or [mode2] is selected for [AEL/AFL] (P. 201) during still photography (note, however, that when [AF] or [AF MF] is selected for AF mode, AE lock is available only in [mode1]).



- If the **AEL/AFL** button has been assigned a different role, you will need to assign [AEL/AFL] (P. 117) to a control using [Button Function] (P. 116).
- If you press the **AEL/AFL** button once, the exposure is locked and is displayed. "Setting Focus and Exposure with the **AEL/AFL** Button (AEL/AFL)" (P. 201)
- Press the **AEL/AFL** button once again to release the AE Lock.
- The lock will be released if you operate the mode dial, **MENU** button, or button.









Performing the sequential/self-timer shooting

Adjust settings for burst or self-timer photography. Choose an option according to your subject. Other options, including anti-shock and silent modes, are also available.

- 1 Press the  button.
- 2 Rotate the rear dial to select a value.
 - Custom self-timer options can be viewed by pressing the **INFO** button.

 Single	Single-frame advance. The camera takes one photo each time the shutter button is pressed all the way down.
 Sequential High	The camera takes photos at up to about 15 fps while the shutter button is held all the way down. Focus, exposure, and white balance are locked at the values for the first shot in each series. You can choose the frame advance rate and the maximum number of shots in each series (P. 220). The frame advance rate drops at [ ISO] settings over 8000.
 Sequential Low	The camera takes photos at up to about 10 fps while the shutter button is held all the way down. You can choose the frame advance rate and the maximum number of shots in each series (P. 220). Focus and exposure conform to the options selected for [ AF Mode] (P. 64, 91) and [ AEL/AFL] (P. 201). If [C-AF], [C-AF MF], [C-AF+TR], or [C-AF+TR MF] is selected for [ AF Mode], the camera will focus before each shot. The frame advance rate drops at [ ISO] settings over 8000.
 12sec	The shutter is released 12 seconds after the shutter button is pressed all the way down. The self-timer lamp will light for about 10 seconds and then start to flash about 2 seconds before the shutter is released. The camera focuses when the shutter button is pressed halfway.
 2sec	When the shutter button is pressed all the way down, the self-timer lamp will start to flash and a photo will be taken after about 2 seconds. The camera focuses when the shutter button is pressed halfway.
 Custom Self-Timer	Adjust self-timer settings, including the self-timer delay and the number of shots taken when the timer expires (P. 80).
 (sample icon) Anti-Shock [	Reduce the slight blur caused by shutter motion (P. 80). Available in single-frame, sequential low, and self-timer modes.









 (sample icon) Silent [♥]	<p>Take pictures with the electronic shutter. Use for shutter speeds faster than 1/8000 s or in settings where the sound of the shutter would be unwelcome (P. 81). Available in single-frame, sequential low, sequential high, and self-timer modes. Frame advance rates of up to 60 fps are available when sequential high is selected. In ♥ mode, focus, exposure, and white balance are locked at the values for the first shot in each series. The flash sync speed is 1/50 s. At [ISO] settings over ISO 8000, the flash sync speed drops to 1/20 s and the maximum frame advance rate to 30 fps.</p>
Pro Cap H Pro Capture High	<p>Capture starts when the shutter button is pressed halfway. The camera starts recording pictures, including those captured while the button was pressed halfway, when the button is pressed all the way down (P. 81). In Pro Cap H mode, focus, exposure, and white balance are locked at the values metered when the shutter button is pressed halfway. At [ISO] settings over ISO 8000, the maximum frame advance rate drops to 30 fps.</p>
Pro Cap L Pro Capture Low	<p>Capture starts when the shutter button is pressed halfway. The camera starts recording pictures, including those captured while the button was pressed halfway, when the button is pressed all the way down (P. 81). In Pro Cap L mode, focus, exposure, and white balance are locked at the values metered when the shutter button is pressed halfway. At [ISO] settings over ISO 8000, the maximum frame advance rate drops to 30 fps.</p>
 High Res Shot	<p>Take high-resolution photos (P. 83). Use [High Res Shot] (P. 158) > [Shooting Method] in Shooting Menu 2 to choose a shooting method.</p>

- To cancel the activated self-timer, press ∇ .
- Fix the camera securely on a tripod for self-timer shooting.
- If you stand in front of the camera to press the shutter button when using the self-timer, the picture may be out of focus.
- In  and  modes, the camera displays the view through the lens during shooting. In  and  modes, it displays the shot immediately preceding the current frame.
- The speed of sequential shooting varies depending on the lens you are using and the focus of the zoom lens.
- During sequential shooting, if the battery level icon blinks due to low battery, the camera stops shooting and starts saving the pictures you have taken on the card. The camera may not save all of the pictures depending on how much battery power remains.
- Some drive modes are not displayed by default. Use [/Settings] (P. 187) in  Custom Menu **D1** to choose the modes displayed.
- Photographs taken in silent and pro-capture modes may be distorted if the subject or camera moves quickly during shooting.
- To use the flash in [Silent [♥]] mode (P. 81), select [Allow] for [Anti-Shock [♦]/Silent [♥]] (P. 157) > [Silent [♥] Mode Settings] > [Flash Mode] in Shooting Menu 2.
- The frame advance rate may slow when [On1] or [On2] is selected for [Live View Boost]. Select [Off] to maintain a consistent frame rate. [/Settings]  Custom Menu **D2** > [Live View Boost] (P. 188)

Self-Timer Options

(Custom Self-timer)

Adjust self-timer settings, including the shutter release delay and the number of shots taken when the timer expires.

- 1 Press the    button.
- 2 Highlight  (custom self-timer) by rotating the rear dial and press the **INFO** button.
- 3 Highlight items using   on the arrow pad and use   to choose an option.











Number of Frames	Choose the number of shots taken when the timer expires.
 Timer	Choose how long the camera waits to begin shooting after the shutter button is pressed all the way down.
Interval Length	If the number of shots is 2 or more, choose the interval between the shots taken when the timer expires.
Every Frame AF	If the number of shots is 2 or more, choose whether the camera focuses before each shot.





Shooting without the vibration caused by shutter button operations (Anti-Shock [)

Reduce the slight blur caused by shutter motion.

Use this option when even slight camera motion can cause blur, for example during macro or telephoto photography.

You must first enable display of this option by selecting [  Settings] (P. 187) in  Custom Menu  and placing a check () next to the appropriate item.

The delay between the shutter button being pressed all the way down and the start of shooting can be selected using [Anti-Shock [/Silent []] > [Anti-Shock []] in  Shooting Menu 2 (P. 157).

- 1 Press the    button.
- 2 Select one of the items marked  using the rear dial and press the  button.
- 3 Take pictures.
 - When the set time has elapsed, the shutter is released and the picture is taken.

Shooting without shutter sound (Silent [♥])

In situations where the shutter sound is a problem, you can shoot without making a sound. An electronic shutter is used to reduce the minuscule camera shake caused by the motion of the mechanical shutter, much as is the case for anti-shock photography. The delay between the shutter button being pressed all the way down and the shutter being released can be selected using [Anti-Shock [♦]/Silent [♥]] > [Silent [♥]] in Shooting Menu 2 (P. 157).

- 1 Press the button.
- 2 Select one of the items marked ♥ using the rear dial and press the button.
- 3 Take pictures.
 - When the shutter is released, the monitor screen will go dark for a moment. No shutter sound will be emitted.
 - The desired results may not be achieved under flickering light sources such as fluorescent or LED lamps or if the subject moves abruptly during shooting.
 - The fastest available shutter speed is 1/32000 s.

Shooting without a release time lag (Pro Capture shooting)

Capture starts when the shutter button is pressed halfway; the moment the button is pressed the rest of the way down, the camera will start saving the last n captured pictures to the memory card, where n is a number selected before shooting begins. If the button is held all the way down, shooting will continue until the selected number of pictures is recorded. Use this option to capture moments you might otherwise miss due to your subject's reactions or shutter lag. Choose from [Pro Capture Low] and [Pro Capture High].

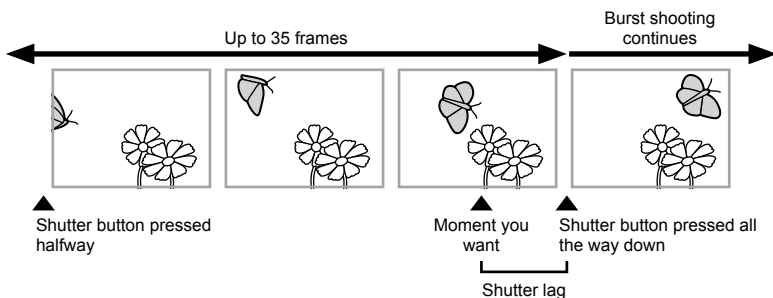











Pro Capture Low (Pro Cap L)

The camera shoots at up to 18 fps. A maximum of 35 frames can be captured before the shutter button is pressed all the way down. If [C-AF], [C-AF MF], [C-AF+TR], or [C-AF+TR MF] is selected for [AF Mode] (P. 64), the camera will focus before each shot. Choose this option if you anticipate that the distance to the subject will change during shooting.

Pro Capture High (Pro Cap H)

The camera shoots at up to 60 fps. A maximum of 35 frames can be captured before the shutter button is pressed all the way down. The camera will use [S-AF] when [C-AF] or [C-AF+TR] is selected for [AF Mode] (P. 64) and [S-AF MF] when [C-AF MF] or [C-AF+TR MF] is selected. Choose this option if the distance to the subject is unlikely to change very much during shooting.

- 1 Press the  button.
 - 2 Select **Pro Cap H** (Pro Capture High) or **Pro Cap L** (Pro Capture Low) using the rear dial and press the  button.
 - 3 Take pictures.
 - Capture starts when the shutter button is pressed halfway. A capture icon () will be displayed. If the button is kept pressed halfway for over a minute, capture will end and the  icon will clear from the display. Press the shutter button halfway again to resume shooting.
 - Press the shutter button all the way down to start saving pictures to the memory card.
 - Shooting will continue while the shutter button is pressed all the way down, up to the number of shots selected for [Frame Count Limiter].
 - [Max fps], [Pre-shutter Frames], and [Frame Count Limiter] can be adjusted using the [L Settings] and [H Settings] options (P. 220) in  Custom Menu .
- Selecting **Pro Cap L** (Pro Capture Low) restricts aperture to values between maximum aperture and f8.0.
 - Pro Capture is not available while the camera is connected to a smartphone.
 - Four Thirds and third-party Micro Four Thirds lenses cannot be used in **Pro Cap L** (Pro Capture Low) mode.
 - Flickering occurred by fluorescent lights or the large movement of the subject, etc. may cause distortions in images.
 - During capture, the monitor will not go dark and the sound of the shutter will not be heard.
 - The slowest shutter speed is limited.
 - Depending on subject brightness and the options selected for [ISO] and exposure compensation, the display frame rate may drop below that selected for [Frame Rate] (P. 188) in  Custom Menu .

Capture icon



Shooting still pictures in a higher resolution (High Res Shot)

Shoot at resolutions higher than that of the image sensor. The camera takes a series of shots while moving the image sensor and combines them to create a single high-resolution photo. Use this option to capture details that normally would not be visible even at high zoom ratios.

Use the [High Res Shot] option (P. 158) in Shooting Menu 2 to choose time between the shutter button being pressed all the way down and the shutter being released, the time allocated for the flash to charge when a flash is used in High Res Shot mode, and the shooting style (tripod-mounted or hand-held).

When High Res Shot is enabled, the image quality mode for High Res Shot can be selected using (P. 100, 142).

1 Press the button.

2 Select using the rear dial.

- To choose between tripod and hand-held modes, press the **INFO** button and rotate the front or rear dial.

3 Press the button.

- A icon will be displayed. The icon will flash if the camera is not steady. The icon stops flashing when the camera is steady and ready to shoot.
- After enabling High Res Shot, check the option selected for image quality. Image quality can be adjusted in the LV super control panel.



Camera readying for High Res Shot (flashes)

4 Take pictures.

- The will flash to warn that shots may be blurred by camera shake. Keep the camera steady.
- Shooting is complete when the green icon clears from the display.
- The camera will automatically create the composite image when shooting is complete. A message will be displayed during this process.
- Choose from JPEG (F, F, or F) and RAW+JPEG modes. When image quality is set to RAW+JPEG, the camera saves a single RAW image (extension “.ORI”) before combining it with the high resolution shooting. Pre-combination RAW images can be played back using the latest version of Olympus Workspace.
- F and F+RAW are unavailable when [Handheld] is selected as the shooting method.
- [S-IS Off] is automatically selected for Image Stabilizer (P. 97) when [Tripod] is chosen for [Shooting Method], [S-IS AUTO] when [Handheld] is selected.
- The maximum wait time for [Shooting Method] > [Handheld] is 1 second.
- During RC flash photography, the maximum flash wait time is 4 seconds and the flash control mode is fixed at MANUAL.
- High Res Shot is available in modes **P**, **S**, **A**, and **M**.

- The following cannot be used:
interval-timer photography, multiple exposure, keystone compensation, bracketing, fisheye correction, and HDR.
- Pictures taken with [e-Portrait] or an art filter selected for picture mode will be recorded in [Natural] mode.
- Image quality may drop under flickering light sources such as fluorescent or LED lamps.
- If the camera is unable to record a composite image due to blur or other factors, only the first shot will be recorded. If [JPEG] is selected for image quality, the shot will be recorded in JPEG format, while if [RAW+JPEG] is selected, the camera will record two copies, one in RAW (.ORF) and the other in JPEG format.

Using a flash (Flash photography)

When using an optional flash unit designed for use with the camera, you can choose the flash mode using camera controls and take pictures with the flash. See the documentation provided with the flash unit for information on flash features and their use.

■ Attaching Compatible Flash Units

The methods used to attach and operate external flash units vary with the unit. See the documentation provided with the unit for details. The instructions here apply to the FL-LM3.

- Confirm that both the camera and flash unit are off. Attaching or removing a flash unit while either the camera or flash unit is on could damage the equipment.

1 Remove the hot shoe cover and attach the flash.

- Slide the flash in until the foot clicks into place at the back of the shoe.

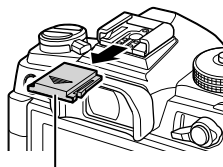

Hot shoe cover

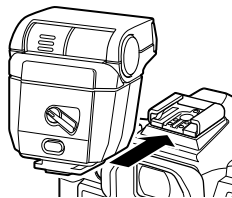

2 Position the flash head for bounce-flash photography or direct lighting.

- The flash head can be rotated up and left or right.
- Note that flash output may be insufficient for correct exposure when bounce flash lighting is used.

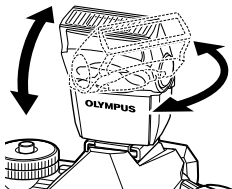

3 Rotate the flash **ON/OFF** lever to the **ON** position.

- Rotate the lever to the **OFF** position when the flash is not in use.

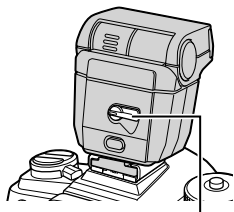

ON/OFF lever

■ Removing Flash Units

1 Keeping the **UNLOCK** button pressed, slide the flash unit from the hot shoe.



UNLOCK button

Choosing a Flash Mode







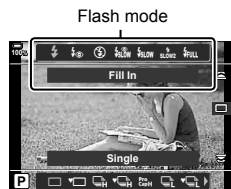







(Flash Mode)



When taking pictures with a flash unit designed for use with the camera, you can select a flash mode using camera controls. Turning an attached flash unit on automatically limits the fastest available shutter speed.

- 1 Press the  button.
- 2 Rotate the front dial to select an option.
 - In manual flash mode, you can adjust flash output by pressing the **INFO** button and rotating the front dial.
 - Manual flash output cannot be adjusted if the flash mode can be selected using the controls on the flash unit.
- 3 Press the shutter button halfway to exit to the shooting display.

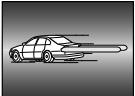







Flash Modes

















 Fill In	<p>Enable the flash.</p> <ul style="list-style-type: none"> • Shutter speed can be set to values between that selected for [ Slow Limit] (P. 236) and [ X-Sync.] (P. 236) in  Custom Menu F.
 Flash Off	<p>Disable the flash.</p> <ul style="list-style-type: none"> • The flash will not fire even if the unit is on.
 Redeye	<p>Reduce “red-eye” in portrait photos. In other respects, the flash functions as it does in  (fill in) mode.</p>
 Slow (slow front-curtain sync)	<p>Slow shutter speeds are used to capture both the main subject and the background.</p> <ul style="list-style-type: none"> • Shutter speed is set according to the exposure value metered by the camera and is not restricted by the option selected for [ Slow Limit].
 Red-Eye Slow	<p> (slow sync) combined with red-eye reduction. The flash is timed using front-curtain sync.</p>
 Slow2 (slow rear-curtain sync)	<p>As for  (slow sync).</p> <ul style="list-style-type: none"> • The flash fires immediately before the shutter closes. Moving objects appear to leave trails of light behind them. 
 Manual Value 1/4, etc.	<p>The flash fires at the selected level.</p>

- Super FP high-speed sync must be configured using flash controls.
- In [] (red-eye reduction) mode, the shutter will be released approximately one second after the initial red-eye reduction pre-flash. Do not move the camera until shooting is complete.
- [] (red-eye reduction) may not produce the desired results in some conditions.



■ Flash Mode and Shutter Speed

The range of shutter speeds available varies with the flash mode. The range of available speeds can be further restricted using the options in the  custom menu.

  Custom Menu  > [ X-Sync.] (P. 236), [ Slow Limit] (P. 236)

Exposure mode	LV super control panel	Flash mode	Flash timing	Shutter speed
P/A		Fill flash	Front-curtain sync	30–1/250 s
		Red-eye		
		Flash off	—	—
		Red-eye slow	Front-curtain sync	60–1/250 s
		Slow		
		Slow	Rear-curtain sync	
		Manual value	Front-curtain sync	30–1/250 s
S/M		Fill flash	Front-curtain sync	60–1/250 s
		Red-eye		
		Flash off	—	—
		Slow	Rear-curtain sync	60–1/250 s
		Manual value	Front-curtain sync	60–1/250 s
B*		Fill flash	Front-curtain sync	—
		Red-eye		
		Flash off	—	—
		Slow	Rear-curtain sync	—
		Manual value	Front-curtain sync	—

* Rear-curtain sync is not available when [LIVE COMP] is selected (P. 54).

- The fastest shutter speed available when the flash fires is 1/250 s. Bright backgrounds in pictures taken with the flash may be overexposed.
- The flash sync speed for silent modes (P. 81), High Res Shot (P. 83), and focus bracketing (P. 148) is 1/50 s. Setting [ ISO] to a value over ISO 8000 when using an option that requires the electronic shutter (for example, silent mode or focus bracketing) sets the flash sync speed to 1/20 s. The flash sync speed is also set to 1/20 s during ISO bracketing (P. 147).
- Even the minimum available flash output may be too bright at short range. To prevent overexposure in pictures taken at short range, select mode **A** or **M** and choose a smaller aperture (higher f-number) or choose a lower setting for [ ISO].

The Super Control/LV Super Control Panel

The super control/LV super control panel lists shooting settings and their current values. Use the LV super control panel when framing shots in the monitor ("live view"), the super control panel when framing shots in the viewfinder.

- Pressing the  (**LV**) button during live view enables viewfinder photography and displays the LV super control panel in the monitor.

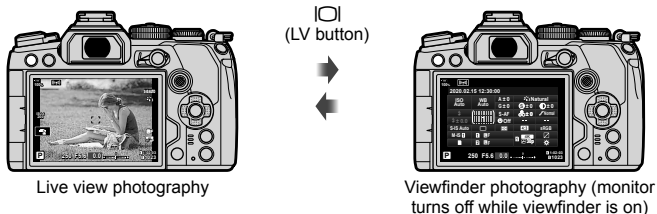

LV Super Control Panel (Live View Photography)

To display the LV super control panel in the monitor, press the  button during live view.

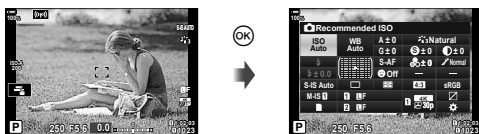

Super Control Panel (Viewfinder Photography)

When you frame subjects in the viewfinder, the super LV control panel will be displayed in the monitor at all times. Press the  button to activate the cursor.

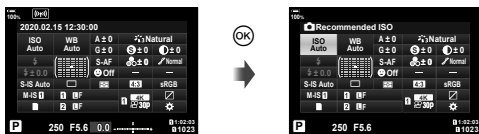

■ Using the Super Control/LV Super Control Panel

1 Press the **OK** button.

- If you press the button during live view, the LV super control panel will be displayed in the monitor.
- The last setting used will be highlighted.

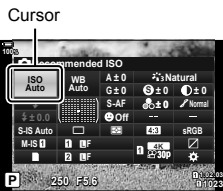

2 Highlight an item using **Δ** **∇** **◀** **▶** on the arrow pad or by rotating the rear dial.

- The selected setting will be highlighted.
- You can also highlight items by tapping them in the display.

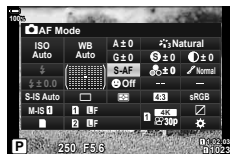
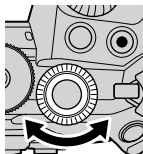

3 Rotate the front dial to change the highlighted setting.

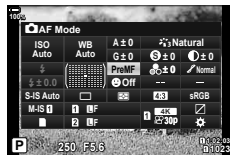
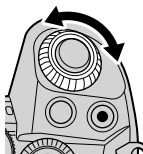

4 Press the shutter button halfway to accept current settings and exit the LV super control panel.

- If you are using the super control panel, the cursor will vanish and setting will end.

Additional Options

Pressing the **OK** button in Step 2 displays options for the highlighted setting. In some cases, additional options can be viewed by pressing the **INFO** button.

OK button

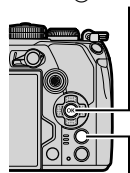

INFO button



INFO



[Image Stabilizer]

- Touch controls can be used in place of the **OK** button. Lightly tap the desired setting twice to display options.

■ Settings Available in the Super Control/LV Super Control Panel

LV super control panel

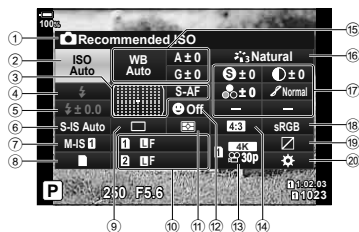

Super control panel

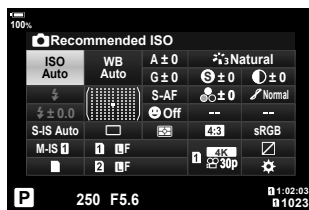

- | | | |
|---|---|--------|
| ① | Currently selected option | |
| ② | ISO sensitivity | P. 75 |
| ③ | AF mode | P. 64 |
| | AF target | P. 69 |
| ④ | Flash mode | P. 86 |
| ⑤ | Flash intensity control | P. 105 |
| | Manual flash output | P. 86 |
| ⑥ | Image stabilizer | P. 97 |
| ⑦ | Image stabilizer | P. 97 |
| ⑧ | Storage options | P. 99 |
| ⑨ | Drive mode (sequential shooting/
self-timer) | P. 78 |
| ⑩ | Image quality | P. 100 |
| ⑪ | Metering mode | P. 77 |
| ⑫ | Face priority | P. 92 |
| ⑬ | Image quality | P. 101 |
| ⑭ | Aspect ratio | P. 98 |
| ⑮ | White balance | P. 94 |
| | White balance compensation | P. 96 |
| | Color temperature*1 | P. 94 |
| ⑯ | Picture mode | P. 106 |
| ⑰ | Sharpness | P. 110 |
| | Contrast | P. 110 |
| | Saturation | P. 110 |
| | Gradation | P. 111 |
| | Color filter | P. 112 |
| | Monochrome color | P. 113 |
| | Effect | P. 113 |
| | Color*2 | P. 109 |
| | Color/Vivid*3 | P. 108 |
| | Effect*4 | P. 109 |
| ⑱ | Color space | P. 114 |
| ⑲ | Highlight & shadow control | P. 115 |
| ⑳ | Button function assignment | P. 116 |

*1 Displayed when CWB (custom white balance) is selected for white balance.

*2 Displayed when Partial Color is set.

*3 Displayed when Color Creator is set.

*4 Displayed when an art filter is selected.

Changing ISO sensitivity (ISO)

You can set the ISO sensitivity. “Changing ISO sensitivity (ISO)” (P. 75)

- Separate options can be selected for still photography and movie mode.

- 1 Press the button to display the LV super control panel.
- 2 Use to select [ISO].
- 3 Use the front dial to select an option.

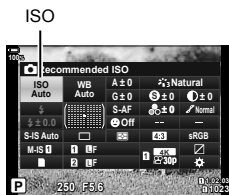

Choosing a focus mode (AF Mode)

You can select a focusing method (focus mode). “Choosing a focus mode (AF Mode)” (P. 64)

- Separate options can be selected for still photography and movie mode.

- 1 Press the button to display the LV super control panel.
- 2 Use to select [AF Mode].
- 3 Use the front dial to select an option.

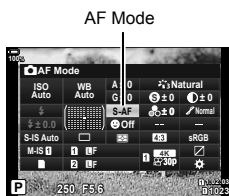

Positioning and Sizing the AF Target (AF Area)

Choose an AF target. “Choosing an AF Target Mode (AF Target Mode)” (P. 69),
“Choosing a Focus Target (AF Target Point)” (P. 72)

- 1 Press the button to display the LV super control panel.
- 2 Highlight [AF Area] using on the arrow pad and press the button.
 - AF-target selection options will be displayed.
- 3 Use the front or rear dial to choose an AF-target mode and to position the AF target.

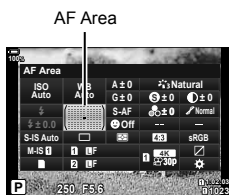

Choosing how the camera measures brightness (Metering)

You can choose how the camera meters subject brightness. “Choosing how the camera measures brightness (Metering)” (P. 77)

- 1 Press the button to display the LV super control panel.
- 2 Use to select [Metering].
- 3 Use the front dial to select an option.

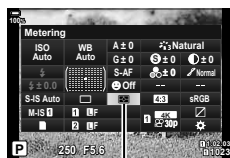

Metering

Face priority AF/Eye priority AF (Face Priority)

The camera automatically detects and focuses on the faces or eyes of portrait subjects. When digital ESP metering is used, exposure will be weighted according to the value metered for the face.

- 1 Press the button to display the LV super control panel.
- 2 Use to select [Face Priority].

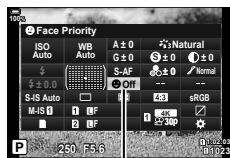

Face priority

- 3 Use the front dial to select an option.

Face Priority On	The camera detects and focuses on faces.
Face Priority Off	Face priority AF off.
Face & Eye Priority On	The camera detects faces and focuses on the eye closest to the camera.
Face & L. Eye Priority On	The camera detects faces and focuses on the left eye.
Face & R. Eye Priority On	The camera detects faces and focuses on the right eye.

4 Point the camera at your subject.

- Faces detected by the camera are indicated by white frames. The face chosen for focus is indicated by brackets at the corners of the frame. If eye-priority AF is enabled, a white frame will appear over one or the other of the selected subject's eyes.
- If multiple faces are detected, the face used for focus can be selected via the control to which [☺ Face Selection] (P. 122) has been assigned using [Button Function] (P. 116). Pressing this control selects the face nearest the AF target. To choose a different face, hold the control and rotate the front or rear dial. Release the control when the desired subject is selected.
- The face used for focus can also be selected via touch controls (P. 43).

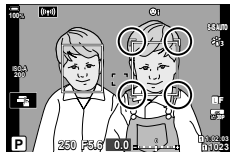

The face chosen for focus is indicated by white double brackets.

5 Press the shutter button halfway to focus.

- The area of the subject used for focus is indicated by a green border.
- If the camera detects the subject's eyes, it will focus on an eye.
- Face and eye priority are also available in [MF] (P. 64). Faces and eyes detected by the camera are indicated by white frames. Exposure will be set according to the value metered for the center of the face.



6 Press the shutter button the rest of the way down to shoot.

- Depending on the subject and the art filter setting, the camera may not be able to correctly detect the face.
- We recommend selecting [Face Priority Off] when photographing non-portrait subjects using [C-AF] or [C-AF MF] in still photography mode.
- When set to [ESP] (Digital ESP metering) (P. 77), metering is performed with priority given to faces.
- If the zoom frame is displayed, the camera will focus on the subject in the zoom frame.
- Even when faces or eyes are detected, you can opt to focus on a target chosen using AF-target selection rather than on the face or eye selected by the camera. [Custom Menu A1] > [AEL/AFL] > [Face Priority AF] (P. 201)
- [Face & Eye Priority On], [Face & L. Eye Priority On], and [Face & R. Eye Priority On] are not available in movie mode.
- Face/eye priority is unavailable if [Spot Metering] (P. 193) is selected during [Spot] metering (P. 77) in single-target AF-target mode (P. 69).



- Using [Button Function] (P. 116), you can assign [☺ Face Priority] (P. 122) to a camera control that you can then press to disable or enable face detection. You can also change [☺ Face Priority] settings by holding the button and rotating the front or rear dial.

Adjusting color

(WB (white balance))

White balance (WB) ensures that white objects in images recorded by the camera appear white. [AUTO] is suitable in most circumstances, but other values can be selected according to the light source when [AUTO] fails to produce the desired results or you wish to introduce a deliberate color cast into your images.

- Separate options can be selected for still photography and movie mode.

- 1 Press the **OK** button to display the LV super control panel.
- 2 Use **Δ** **▽** **<** **>** to select [WB].

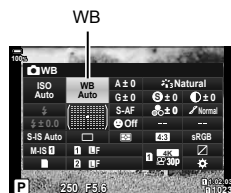

- 3 Use the front dial to select an option.
 - One-touch white balance and custom white balance options can be viewed by pressing the **OK** button followed by the **INFO** button.

WB mode		Color temperature	Light conditions
Auto white balance	AUTO	—	Most normal scenes (scenes containing objects that are white or close to white) <ul style="list-style-type: none"> • This mode is recommended in most situations. • You can choose the white balance used under incandescent lighting (P. 96).
Preset white balance		5300 K	Sunlit outdoor scenes, sunsets, fireworks
		7500 K	Daylight shots of subjects in the shade
		6000 K	Shots taken in daylight under overcast skies
		3000 K	Subjects under incandescent lighting
		4000 K	Subjects under fluorescent lighting
		—	Underwater photography
		5500 K	Light sources with the same color temperature as flash lighting
One-touch white balance		Color temperature set by one-touch WB	Situations in which you want to set white balance for a specific subject <ul style="list-style-type: none"> • Color temperature is set to a value metered from a white object under the lighting what will be used in the final photograph (P. 95).
Custom white balance	CWB	2000 K–14000 K	Situations in which you can identify the appropriate color temperature <ul style="list-style-type: none"> • Choose a color temperature.

■ One-touch white balance

Measure white balance by framing a piece of paper or other white object under the lighting that will be used in the final photograph. Use this option to fine-tune white balance when you find it hard to obtain the desired results with white balance compensation or preset white balance options such as ☀ (sunlight) or ☁ (overcast). The camera stores the metered value for quick recall as required.

- 1 After selecting [☀], [☁], [☁], or [☁] (one-touch white balance 1, 2, 3, or 4), press the **OK** button followed by the **INFO** button.
- 2 Photograph a piece of colorless (white or gray) paper.
 - Frame the piece of paper so that it fills the display. Ensure that it is free of shadows.
 - In still photography mode, press the **INFO** button and then the shutter button.
 - In movie mode, press the **INFO** button to release the shutter.
 - The one-touch white balance screen appears.
- 3 Select [Yes] and press the **OK** button.
 - The new value is saved as a preset white balance option.
 - The new value is stored until one-touch white balance is measured again. Turning the power off does not erase the data.

Metering White Balance with the One-Touch White Balance Button (☁)

Assigning [☁] to a button allows the control to be used to measure white balance. By default, the **OK** button can be used to measure white balance during still photography. To measure white balance during movie recording, you must first assign one-touch white balance to a control using [☁] Button Function] (P. 116).

- 1 Frame a piece of colorless (white or gray) paper in the center of the display.
 - Frame the piece of paper so that it fills the display. Ensure that it is free of shadows.
- 2 Hold the one-touch WB button and press the shutter button all the way down.
 - When recording movies, press the one-touch white balance button to proceed to Step 3.
 - You will be prompted to choose the one-touch white balance option that will be used to store the new value.

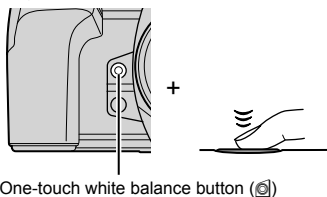

One-touch white balance button (☁)

- 3 Highlight a one-touch white balance setting using **△**/**▽** on the arrow pad and press the **OK** button.
 - The new value will be saved as the value for the selected setting and the camera will exit to the shooting display.

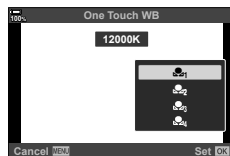

WB AUTO Keep Warm Color

Choose how the camera adjusts white balance for pictures taken using auto white balance under incandescent lighting.

- 1 After selecting [AUTO], press the **INFO** button.
 - [WB AUTO Keep Warm Color] options will be displayed.
- 2 Highlight an option using Δ ∇ \langle \rangle on the arrow pad and press the **OK** button.

Off	The camera suppresses the warm tones produced by incandescent lighting.
On	The camera preserves the warm tones produced by incandescent lighting.

Making fine adjustments to white balance (WB Compensation)

Fine-tune white balance. Separate values can be selected for each white balance option. Adjust settings as described below.

A A (amber–blue) axis	Positive values add a red cast, negative values a blue cast.
G G (green–magenta) axis	Positive values add a green cast, negative values a magenta cast.

- 1 Press the **OK** button to display the LV super control panel.
- 2 Highlight [A±0] or [G±0] using the arrow pad and highlight the desired value using the front dial.
 - The effect can be previewed by pressing the **OK** button.

White balance compensation

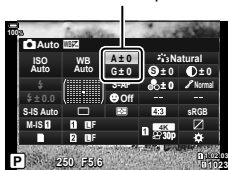

- White balance compensation can be applied to all white balance modes simultaneously.
 - Custom Menu **G** > [All WB] (P. 194), Video Menu > [Specification Settings] > [All WB] (P. 161)



- Changes to white balance can be previewed in live view. During still photography, the effect can be previewed in a photograph. Press the **MOVIE** button in the white balance compensation display to view an image captured at current settings.

Reducing camera shake

(Image Stabilizer)

You can reduce the amount of camera shake that can occur when shooting in low light situations or shooting with high magnification.

- 1 Press the **OK** button to display the LV super control panel.
- 2 Use **△ ▽ ◀ ▶** to select the image stabilizer.

 Image Stabilizer







 Image Stabilizer

- 3 Use the front dial to select an option.

Still picture (S-IS)	S-IS Off	Still-I.S. Off	Image stabilization disabled. Select this option when using a tripod.
	S-IS AUTO	Auto I.S.	Image stabilization applies to motion on all axes. If panning motion is detected, the camera will automatically suspend image stabilization on that axis.
	S-IS 1	All Direction Shake I.S.	Image stabilization applies to motion on all axes.
	S-IS 2	Vertical Shake I.S.	Image stabilization applies to vertical motion. Use when panning the camera horizontally.
	S-IS 3	Horizontal Shake I.S.	Image stabilization applies to horizontal motion. Use when panning the camera vertically.
Movie (M-IS)	M-IS Off	Movie-I.S. Off	Image stabilizer is off.
	M-IS 1	All Direction Shake I.S.	Electronic image stabilization combined with VCM-controlled image sensor movement.
	M-IS 2	All Direction Shake I.S.	VCM-controlled image sensor movement only.

- Image stabilization may be unable to compensate for excessive camera motion or very slow shutter speeds. Use a tripod in these cases.
- You may notice noise or vibration while image stabilization is in effect.
- The setting selected with the lens image stabilization switch, if any, takes priority over that selected with the camera.
- [S-IS AUTO] functions as [S-IS 1] when [On] is selected for [Lens I.S. Priority].



- You can choose whether image stabilization will be performed while the shutter button is pressed halfway.   Custom Menu **C2** > [Half Way Rls With IS] (P. 186)
- You can prioritize lens image stabilization.   Custom Menu **C2** > [Lens I.S. Priority] (P. 186)

Using lenses other than Micro Four Thirds/Four Thirds System lenses

When using lenses other than Micro Four Thirds or Four Thirds system lenses, you will need to specify the lens focal length.

- Set [Image Stabilizer], press the **OK** button, press the **INFO** button, then use $\Delta \nabla \langle \triangleright \rangle$ to select a focal length, and press the **OK** button.
- Choose a focal length between 0.1 mm and 1000.0 mm.
- Choose the value that matches the one printed on the lens.
- The selected value is not reset when you select [Reset / Custom Modes] (P. 141) > [Reset] (basic) in \blacksquare Shooting Menu 1.

Performing the sequential/self-timer shooting

You can take a series of pictures by keeping the shutter button pressed all the way down. Alternatively, you can take pictures using the self-timer. Other options, including anti-shock and silent modes, are also available. \blacksquare “Performing the sequential/self-timer shooting” (P. 78–83)

- 1 Press the **OK** button to display the LV super control panel.
- 2 Use $\Delta \nabla \langle \triangleright \rangle$ to select the sequential shooting/self-timer.
- 3 Use the front dial to select an option.

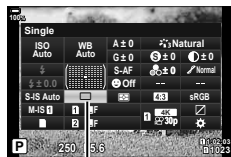

Sequential shooting/
self-timer

Setting the image aspect

Choose the ratio of width to height for pictures according to your intent or your goals for printing or the like. In addition to the standard aspect (width-to-height) ratio of [4:3], the camera offers settings of [16:9], [3:2], [1:1], and [3:4].

- 1 Press the **OK** button to display the LV super control panel.
- 2 Use $\Delta \nabla \langle \triangleright \rangle$ to select [Aspect].
- 3 Use the front dial to select an option.

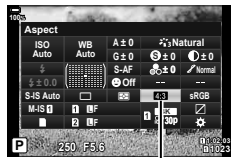

Aspect

- Image aspect can only be set for still images.
- JPEG images are recorded at the selected aspect ratio. RAW images are the same size as the image sensor and are recorded at an aspect ratio of 4:3 with a tag indicating the aspect ratio selected. A crop indicating the selected aspect ratio is displayed when images are played back.

Setting the saving method for shooting data (Save Settings)





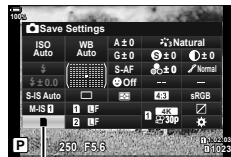

Choose how the camera stores pictures when two memory cards are inserted.

- 1 Press the **OK** button to display the LV super control panel.
- 2 Use **△ ▽ ◀ ▶** to select [**Save Settings**].



Save Settings

- 3 Use the front dial to select an option.

 Standard	Pictures are recorded to the memory card in the slot selected for [Save Slot] (P. 237). Shooting ends when the card is full.
 Auto Switch	Pictures are recorded to the memory card in the slot selected for [Save Slot] (P. 237). Pictures will be recorded to the remaining card when the card in the selected slot fills. This setting automatically reverts to [Standard] when only one memory card is inserted.
 Dual Independent ↓	Each picture is recorded twice, once in each of two different image quality formats. Choose an image quality for each slot (P. 100). Shooting ends when either card is full. Image quality is set separately for each slot; after changing the option selected, check the current image quality setting.
 Dual Independent ↑	Each picture is recorded twice, once in each of two different image quality formats. Choose an image quality for each slot (P. 100). Recording continues to the card in the remaining slot when either card fills. Image quality is set separately for each slot; after changing the option selected, check the current image quality setting.
 Dual Same ↓	Each picture is recorded twice, once to each card, using the option currently selected for image quality. Shooting ends when either card is full. This setting automatically reverts to [Standard] when only one memory card is inserted.
 Dual Same ↑	Each picture is recorded twice, once to each card, using the option currently selected for image quality. Recording continues to the card in the remaining slot when either card fills. This setting automatically reverts to [Standard] when only one memory card is inserted.

- If you press the **OK** button, you can specify the card to record the shooting data to with [Card Slot Settings] of **Custom Menu H1** (P. 237).
- The image quality mode may change if you change the option selected for [**Save Settings**] or replace a memory card with one that can contain a different amount of additional photographs. Check the image quality mode before taking photographs.

Photo File and Image Size Options



You can set an image quality mode for still images. Select a quality suitable for the application (such as for processing on PC, use on website etc.).

- 1 Press the **OK** button to display the LV super control panel.
- 2 Use **Δ ▽ ◀ ▶** to select **[📷 ↵]**.
 - When [Dual Independent ↓] or [Dual Independent ↑] is selected for **[📷 Save Settings]**, a different setting can be used for each slot (P. 99).



- 3 Use the front dial to select an option.
 - Choose from the following options. The image size/compression combinations available can be selected in the menus. **[📷] ⚙ Custom Menu [G] > [📷 ↵] Set** (P. 236)

Option	Image size	Compression ratio	File format
[SF]	5184 × 3888	SuperFine (1/2.7)	JPG
[F]	5184 × 3888	Fine (1/4)	JPG
[N]	5184 × 3888	Normal (1/8)	JPG
[M]	3200 × 2400	Normal (1/8)	JPG
RAW	5184 × 3888	Lossless compression	ORF
RAW+JPEG	RAW plus the JPEG option selected above		

- When [Standard], [Dual Same ↓], or [Dual Same ↑], or [Auto Switch] is selected for [Card Slot Settings] > **[📷 Save Settings]** (P. 237) in **⚙ Custom Menu [11]**, the selected option applies to the cards in both slots **[1]** and **[2]**.
- During the high resolution shooting (P. 83), you can select between **[80M] F**, **[60M] F**, **[25M] F**, **[80M] F+RAW**, **[50M] F+RAW**, and **[25M] F+RAW**.
- **[80M] F** and **[80M] F+RAW** are unavailable when [Handheld] is selected for High Res Shot.
- Selecting High Res Shot changes the image quality option selected; be sure to check the image quality setting before shooting.



- RAW files store raw image data in an unprocessed state. Choose this format (extension “.ORF”) for pictures that will later be enhanced.
 - Cannot be viewed on other cameras
 - Can be viewed on computers using Olympus Workspace Digital Photo Managing software
 - Can be saved in JPEG format using the [RAW Data Edit] (P. 170) retouch option in the camera menus

Frame Size, Rate, and Compression



Choose the image quality options available for movie recording.

When choosing an option, consider how the movie will be used: for example, are you planning to process it on a computer, or is it intended for upload to a website? The camera can store multiple combinations of frame size, rate, and compression from which you can select according to your goals. Slow- and fast-motion and high-speed movie options are also available. For more information, see “Filming Slow- or Fast-Motion Movies (Slow- and Fast-Motion Movies)” (P. 104) and “Filming High-Speed Movies” (P. 103)

- 1 Press the **OK** button to display the LV super control panel.
- 2 Use Δ ∇ \triangleleft \triangleright to select

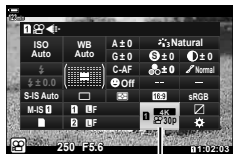

- 3 Use the front dial to select an option.
 - To change movie record mode settings, press **OK** followed by the **INFO** button and rotate the rear dial.

The Movie Quality Icon

Changes to settings are reflected in the  icon as shown below.



Frame size

FHD	Full HD* ¹	1920 × 1080
HD	HD* ¹	1280 × 720
4K	4K* ¹	3840 × 2160
C4K	4K Digital Cinema* ¹	4096 × 2160



Compression/bit rate

A-I	All Intra* ²	<ul style="list-style-type: none"> • Not available when [4K] or [C4K] is selected for [Movie Resolution].
SF	Super Fine	
F	Fine	
N	Normal	

Frame rate

60p	60p: 59.94 fps	<ul style="list-style-type: none"> • [60p] and [50p] are not available when: <ul style="list-style-type: none"> - [FHD] is selected for [Movie Resolution] and [A-I] is selected for bit rate - [4K] or [C4K] is selected for [Movie Resolution] • Selecting [C4K] for [Movie Resolution] fixes [Frame Rate] at [24p].
50p	50p: 50.00 fps	
30p	30p: 29.97 fps	
25p	25p: 25.00 fps	
24p	24p: 23.98 fps 24p: 24.00 fps (C4K)	

Movie type

	Setting 1, 2, 3, or 4: Save up to four combinations of frame size, rate, and compression for later use.
	Custom: Choose frame sizes of 4K or 4K Digital Cinema. You can also shoot fast- or slow-motion movies (P. 104).
—	High-speed movie  "Filming High-Speed Movies" (P. 103)

*1 Movies are saved in MPEG-4 AVC/H.264 format. Individual movie files can be up to 4 GB in size. Continuous shots can be no more than 29 minutes in length.

*2 "All-Intra" movies use no inter-frame compression. This suits them to editing but increases file size.

- Depending on the card used, recording may end before the maximum length is reached.
- Bit-rate selection may be unavailable at some settings.
- Movies are recorded at an aspect ratio of 16:9. C4K movies are recorded at an aspect ratio of 17:9.

Filming High-Speed Movies

Film at high frame rates. Movies are filmed at 120 fps and play back at 60 fps. Stretching playback to double the recording time (as is the case when 60p is selected as the playback frame rate) lets you view in slow motion movements that in real life took only the blink of an eye.

A high-speed movie option can be included in the movie image quality menu. Your choice of playback frame rate determines the playback speed multiplier.

Changes to settings are reflected in the movie quality icon as shown.

	Frame size	FHD Full HD (1920 × 1080)
	Movie type	HS High speed (120 fps)
	Playback frame rate	60p 60p: 59.94 fps; plays back at 0.5× speed
		50p 50p: 50.00 fps; plays back at 0.42× speed
		30p 30p: 29.97 fps; plays back at 0.25× speed
		25p 25p: 25.00 fps; plays back at 0.21× speed
		24p 24p: 23.98 fps; plays back at 0.2× speed

1 Select **FHD HS 60p** (high-speed movie recording).

- To use current settings, press the **OK** button. The camera will exit the menu with the current options selected.

2 To edit current settings, press the **INFO** button in Step 1.

- This places the cursor in the list of high-speed movie options.

3 Choose the playback frame rate.

- Use **Δ** **▽** on the arrow pad to highlight the desired playback frame rate.

4 Press the **OK** button to select the highlighted option and exit.

- Focus, exposure, and white balance lock during recording.
- Sound is not recorded.
- The picture angle is slightly reduced.
- Aperture, shutter speed, exposure compensation, and ISO sensitivity cannot be changed during recording.
- Time codes cannot be recorded or displayed.
- Brightness may change if zoom is adjusted during recording.
- Individual movies can be up to 4 GB in size.
- High-speed movie recording is not available while the camera is connected to an HDMI device.
- [Image Stabilizer] > [M-IS] is not available.
- [Movie] cannot be used.
- [i-Enhance], [e-Portrait], and art filter picture modes are not available.
- [Gradation] is fixed at [Gradation Normal].
- High-speed movie recording is not available during remote photography when the camera is connected to a smartphone.



Filming Slow- or Fast-Motion Movies





(Slow- and Fast-Motion Movies)

You can create slow motion or fast-motion movies. You can set the recording speed using  in record mode.



1 Press the  button to display the LV super control panel.

2 Use     to select [ ].

3 Use the front dial to select  (custom record mode) (P. 102), then press the  button.

- The option selected for [Slow or Fast Motion] can be changed by pressing the **INFO** button. After highlighting [Slow or Fast Motion] using  , use   to choose a speed multiplier and then press the  button. Choose high multipliers for fast-motion movies, low multipliers for slow-motion movies. The frame rate changes accordingly.

4 Press the  button to start shooting.



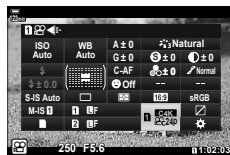

- Press the  button again to end shooting.
- The movie will be played back at a fixed speed so that it appears to be in slow motion or fast-motion.
- Sound will not be recorded.
- Any picture mode art filters will be canceled.
- Either or both of slow motion and fast-motion cannot be set for some options of [ ].
- Shutter speed is limited to values no slower than 1/24 s. The slowest speed available varies with the option selected for [Frame Rate].



Choosing a Flash Mode

(Flash Mode)

When taking pictures with a flash unit designed for use with the camera, you can select a flash mode using camera controls.  “Choosing a Flash Mode (Flash Mode)” (P. 86)

- 1 Press the  button to display the LV super control panel.
- 2 Use    to select [Flash Mode].
- 3 Use the front dial to select an option.
 - Flash settings can be accessed via the LV super control panel.







Flash mode

Adjusting flash output



Flash output can be adjusted if you find that your subject is over- or under-exposed even though the exposure in the rest of the frame is appropriate.

Flash compensation is available in modes other than [ Manual] (manual).

- 1 Press the  button to display the LV super control panel.
- 2 Use    to select [].
- 3 Use the front dial to select an option.

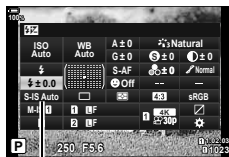













- Changes to flash intensity made with the external flash unit are added to those made with the camera.



Choose how pictures are processed during shooting to enhance color, tone, and other properties. Choose from preset picture modes according to your subject or artistic intent. Contrast, sharpness, and other settings can be adjusted separately for each mode. You can also add artistic effects using art filters. Art filters give you the option of added frame effects and the like. Adjustments to individual parameters are stored separately for each picture mode and art filter.

- This item applies during both still photography and movie recording.

Picture mode options



 i-Enhance	The camera adjusts colors and contrast for optimal results according to the type of subject (P. 113).
 Vivid	Choose for vivid colors.
 Natural	Choose for natural colors.
 Muted	Choose for pictures that will later be retouched.
 Portrait	Enhance skin tones.
 Monochrome	Record pictures in monochrome. You can apply color filter effects and choose a tint (P. 113).
 Custom	Adjust picture mode parameters to create a custom version of a selected picture mode.
 e-Portrait	Smooth complexions.
 Underwater	Process pictures to preserve the vivid colors seen under water. • We recommend choosing [Off] for [⚡+WB] (P. 193) when this option is selected.
 Color Creator	Adjust hue and color to suit your creative intent (P. 108).
ART 1 Pop Art	Uses Art Filter settings. Art effects can also be used.
ART 2 Soft Focus	
ART 3 Pale&Light Color	
ART 4 Light Tone	
ART 5 Grainy Film	
ART 6 Pin Hole	
ART 7 Diorama	
ART 8 Cross Process	
ART 9 Gentle Sepia	
ART 10 Dramatic Tone	
ART 11 Key Line	
ART 12 Watercolor	
ART 13 Vintage	
ART 14 Partial Color	
ART 15 Bleach Bypass	
ART 16 Instant Film	

 Flat*	Movies are recorded using a tone curve adapted to color grading.
 OM-Log400*	Movies are recorded using a log tone curve for greater freedom during color grading.



* Displayed in movie mode when [On] is selected for [ Specification Settings] > [ Picture Mode] in the [ Video Menu] (P. 161).

- Art filters apply only to the JPEG copy. [RAW+JPEG] is automatically selected for image quality in place of [RAW].
- Depending on the scene, the effects of some settings may not be visible, while in other cases tone transitions may be ragged or the image rendered more “grainy”.



- You can hide or reveal picture modes using [Picture Mode Settings] (P. 187) in  Custom Menu .

1 Press the  button to display the LV super control panel.

2 Use    to select [Picture Mode].

Picture Mode

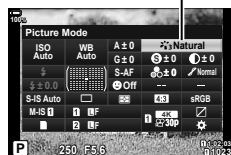

3 Use the front dial to select an option.

- Depending on the option selected, picture mode parameters may be displayed in LV super control panel. Adjust parameters as desired (P. 110–113).

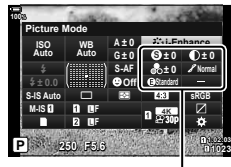

Changes depending on mode selected

Adjusting overall color

(Color Creator)

The camera permits intuitive adjustments to color saturation and hue. Choose from 30 hues and 8 levels of saturation. The results can be previewed in the display.

- 1 Press the **OK** button to display the LV super control panel.
- 2 Use **Δ ∇ ◀ ▶** to select [Picture Mode].
- 3 Rotate the front dial to highlight [Color Creator].
 - A **Color/Vivid** item will appear in the LV super control panel.
- 4 Highlight [**Color/Vivid**] using **Δ ∇** and press the **OK** button.
- 5 Adjust saturation and hue.
 - Rotate the front dial to adjust hue.
 - Rotate the rear dial to adjust saturation.
 - To restore default values, press and hold the **OK** button.

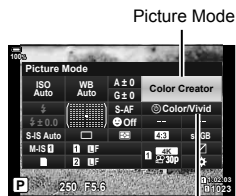

Color/Vivid



- 6 Press the **OK** button to save changes.
 - You can also save changes by pressing the shutter button halfway.
- Photos are recorded in RAW+JPEG format when [RAW] is selected for image quality (P. 100, 142).
 - Pictures taken using [HDR] (P. 152) or [Multiple Exposure] (P. 154) are recorded at the [Natural] setting.
 - [Color Creator] can be assigned to a camera control. It can be accessed via buttons assigned the [Multi Function] (P. 124) role using [Button Function] (P. 116).

Shoot in black-and-white while capturing objects of a selected hue in color. For example, you can shoot in black-and-white while leaving only reds in color. The results can be previewed in the display.

[Partial Color] is an art filter option. Settings can be adjusted when it is selected for picture mode. Choose from three “leave color” filters (I through III).

1 Press the **OK** button to display the LV super control panel.

2 Use **Δ ∇ <|>** to select [Picture Mode].

Picture Mode

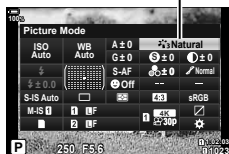

3 Highlight [ART14 I], [ART14 II], or [ART14 III] using the front dial.

- [Color] and [Effect] options will be displayed in the LV super control panel.

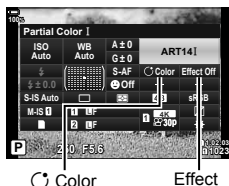

4 Highlight [Color] using **Δ ∇** on the arrow pad and press the **OK** button.

- A color ring will be displayed.

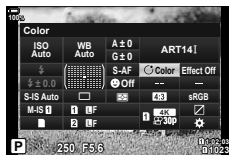

5 Select a color using the dials.

6 Press the **OK** button to save changes.

- You can also save changes by pressing the shutter button halfway.

Making fine adjustments to sharpness (Sharpness)

Adjust image sharpness. Outlines can be emphasized for a sharp, clear picture. Settings are stored separately for each picture mode.

- 1 Press the **OK** button to display the LV super control panel.
- 2 Use **Δ ▽ ◀ ▶** to select [Sharpness].
- 3 Use the front dial to select an option.

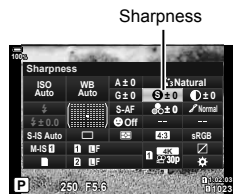

Making fine adjustments to contrast (Contrast)

Adjust image contrast. Increasing contrast heightens the difference between bright and dark areas for a harder, more well-defined picture. Settings are stored separately for each picture mode.

- 1 Press the **OK** button to display the LV super control panel.
- 2 Use **Δ ▽ ◀ ▶** to select [Contrast].
- 3 Use the front dial to select an option.

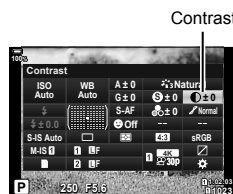

Making fine adjustments to saturation (Saturation)

Adjust color saturation. Increasing saturation makes pictures more vivid. Settings are stored separately for each picture mode.

- 1 Press the **OK** button to display the LV super control panel.
- 2 Use **Δ ▽ ◀ ▶** to select [Saturation].
- 3 Use the front dial to select an option.

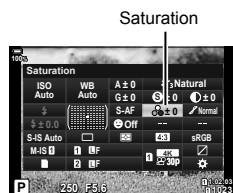

Making fine adjustments to tone (Gradation)

Adjust color brightness and shading. Bring pictures closer to what you envisage by, for example, brightening the entire picture. Settings are stored separately for each picture mode.

- 1 Press the **OK** button to display the LV super control panel.
- 2 Use **△ ▽ ◀ ▶** to select [Gradation].

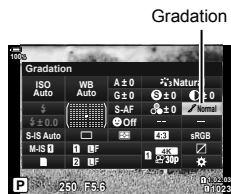

- 3 Use the front dial to select an option.

Auto (Shadow Adj)	Divides the image into detailed regions and adjusts the brightness separately for each region. This is effective for images with areas of large contrast in which the whites appear too bright or the blacks appear too dark.
Normal (Gradation Normal)	Optimal shading. Recommended in most circumstances.
High (Gradation High Key)	Uses a tone suitable for a bright subject.
Low (Gradation Low Key)	Uses a tone suitable for a dark subject.

Adjusting the tone of a monochrome image (Monochrome Color)

Add a tint to black-and-white pictures in the [Monochrome] picture mode (P. 106).

- 1 Press the **OK** button to display the LV super control panel.
- 2 Use **△ ▽ < ▷** to select [Picture Mode].
- 3 Select [Monochrome] using the front dial.
- 4 Use **△ ▽ < ▷** to select [Monochrome Color].

Monochrome Color

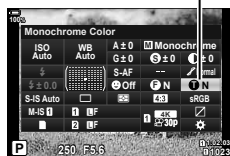

- 5 Use the front dial to select an option.

N:Normal	Creates a normal black and white image.
S:Sepia	Shoot in sepia-tinted monochrome.
B:Blue	Shoot in blue-tinted monochrome.
P:Purple	Shoot in purple-tinted monochrome.
G:Green	Shoot in green-tinted monochrome.

Adjusting i-Enhance effects (Effect)

Choose the strength of the i-Enhance effect when [i-Enhance] is selected for picture mode (P. 106).

- 1 Press the **OK** button to display the LV super control panel.
- 2 Use **△ ▽ < ▷** to select [Effect].



Effect







- 3 Use the front dial to select an option.

Low (Effect: Low)	Adds a low i-Enhance effect to images.
Standard (Effect: Standard)	Adds an i-Enhance effect between "low" and "high" to images.
High (Effect: High)	Adds a high i-Enhance effect to images.

Setting the color reproduction format (Color Space)

You can select a format to ensure that colors are correctly reproduced when shot images are regenerated on a monitor or using a printer. This option is equivalent to the [Color Space] (P. 194) in  Custom Menu .

- 1 Press the  button to display the LV super control panel.
- 2 Use     to select [Color Space].



Color Space

- 3 Use the front dial to select an option.

sRGB	The established color space standard for Windows systems. It is widely supported across displays, printers, digital cameras, and computer applications. This setting is recommended in most circumstances.
AdobeRGB	A color space standard defined by Adobe Systems Inc. It can reproduce a wider gamut of colors than sRGB. Accurate color reproduction is available only with software and devices (displays, printers, and the like) that support this standard. An underscore (“_”) appears at the beginning of the file name (e.g., “_xxx0000.jpg”).

- [AdobeRGB] is not available in HDR or movie () mode or when an art filter is selected for picture mode.

Changing the brightness of highlights and shadows (Highlight&Shadow Control)

Adjust brightness separately for highlights, mid-tones, and shadows. You gain greater control over exposure than you would with exposure compensation alone. You can selectively make highlights darker or shadows brighter.

- 1 Press the **OK** button to display the LV super control panel.

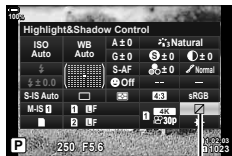

Highlight&Shadow Control

- 2 Use Δ ∇ \triangleleft \triangleright to select [Highlight&Shadow Control], then press the **OK** button.

- 3 Press the **INFO** button to choose the desired tone range.

- The tone range changes each time the button is pressed.



Selected tone range

- 4 Rotate the dials to choose the desired setting.

- **[Hi. & Sh.] selected**
Adjust highlights using the front dial and shadows using the rear dial.
- **[Midtone] selected**
Use the front or rear dial.
- Press and hold the **OK** button to restore the default curve.



- 5 Press the **OK** button to save changes.

- You can also save changes by pressing the shutter button halfway.

- [Highlight & Shadow Control] can be assigned to a button. Select [Multi Function] (P. 124) for [Button Function] (P. 116).

Other roles can be assigned to buttons in place of their existing functions.

The functions assigned using [📷 Button Function] take effect only during still photography (P. 185). The functions assigned using [🎥 Button Function] take effect in 🎥 (movie) mode (P. 163).

■ Customizable Controls

Icon	Button	Default role
	(exposure compensation) button	(exposure compensation)
	(movie) button	(movie recording)
	(LV) button	(display selection)
	AEL/AFL button	(exposure/focus lock)
	ISO button	ISO (ISO sensitivity)
	Arrow pad	[::] (AF-target position)
	Arrow pad ▷ (right) ^{*1}	Still picture: (flash) Movie: W↔T (electronic zoom) ^{*2}
	Arrow pad ▽ (down) ^{*1}	Still picture: (sequential shooting/ self-timer) Movie: WB (white balance)
	One-touch white balance button	Still picture: (one-touch white balance) Movie: PEAK (peaking)
	Preview button	Still picture: (preview) Movie: Q (magnify)
	Optional power battery holder B-Fn1 button	ISO (ISO sensitivity)
	Optional power battery holder B-Fn2 button	(exposure/focus lock)
	Optional power battery holder arrow pad	Still picture: [::] (AF-target position) Movie: (direct function)
	Optional power battery holder arrow pad ▷ (right) ^{*3}	Still picture: (flash) Movie: W↔T (electronic zoom) ^{*2}
	Optional power battery holder arrow pad ▽ (down) ^{*3}	Still picture: (sequential shooting/ self-timer) Movie: WB (white balance)
	L-Fn button (lens focus function buttons)	AF Stop

*1 To use ▷ and ▽ on the arrow pad in their assigned roles, select [Direct Function] for [↔] (arrow pad).

*2 Only available with power zoom lenses.

*3 To use ▷ and ▽ on the power battery holder arrow pad in their assigned roles, select [Direct Function] for [PBH↔].

To change the function assigned to a button, follow the steps below.

1 Press the **OK** button to display the LV super control panel.

2 Use $\Delta \nabla \triangleleft \triangleright$ to select [Button Function], then press the **OK** button.

- [**☑** Button Function] of **☑ Custom Menu B1** (P. 185) is displayed in still image shooting mode, and [**📷** Button Function] of [**📷** Button/Dial/Lever] (P. 163) is displayed in movie mode.

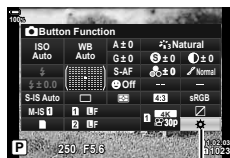

Button Function















3 Highlight the desired control using $\Delta \nabla$ on the arrow pad and press the **▷** button.

























4 Highlight a function using the $\Delta \nabla$ buttons and press the **OK** button to assign it to the selected control.











- The options available vary from button to button.

■ Available Roles



Role	Function
AF Stop	Suspend autofocus. Focus locks and autofocus is suspended while the control is pressed. Applies only to lens L-Fn buttons.
AEL/AFL (AE/AF-L)	Lock focus and/or exposure. When used for exposure lock, the control locks exposure when pressed and releases the lock when pressed a second time. The behavior of the control can be selected using [☑ AEL/AFL] in ☑ Custom Menu A1 (P. 201).
REC (movie recording)	The control functions as a movie-record button. Press to start or stop recording.
Direct Function (☑/⏏/⏏/⏏)	Assign roles to the buttons on the arrow pad ($\Delta \nabla \triangleleft \triangleright$). The following roles can be assigned: \triangleleft button: [⏏] (AF-target selection) Δ button: [☑] (exposure compensation) \triangleright button: [⚡] (flash) (still picture) / electronic zoom (movie) ∇ button: [📷/📷] (drive mode) (still picture) / WB (movie) <ul style="list-style-type: none"> • The \triangleright and ∇ buttons can be assigned other functions.
Preview (📷)	Stop aperture down to the selected value. This lets you preview depth of field. Aperture stops down to the currently-selected value while the button is pressed. Preview options can be selected using [📷 Settings] in ☑ Custom Menu D2 (P. 189). <ul style="list-style-type: none"> • This role is available for [☑ Button Function] only.









Role	Function
 (one-touch white balance)	<p>Measure a value for one-touch white balance (P. 94, 95).</p> <p>To measure white balance during still photography, frame a reference object (a piece of white paper or the like) in the display, then press and hold the control and press the shutter button. A list of one-touch white balance options will be displayed, from which you can choose the location to which the new value will be saved.</p> <p>To measure white balance during movie recording, frame a reference object (a piece of white paper or the like) in the display and press the button. A list of one-touch white balance options will be displayed, from which you can choose the location to which the new value will be saved.</p>
AF Area Select ([:~:~])	<p>You can choose the AF-target mode (P. 69) and position (P. 72). Press the control to view the AF-target selection display. Use the front or rear dial to choose AF-target mode and the multi selector or arrow pad to position the AF target.</p> <ul style="list-style-type: none"> You can choose the controls used for this operation.   Custom Menu A2 > [:~:~] Select Screen Settings] (P. 207)
[:~:~] Home (AF home position) ([:~:~]HP)	<p>Recall previously-saved [AF Mode], [AF Target Mode], and [AF Target Point] "home position" settings. Press the control to recall saved settings and press it again to restore the settings previously in effect. Home position settings are saved using [:~:~] Set Home] in  Custom Menu A2 (P. 206).</p> <ul style="list-style-type: none"> This role is available for  Button Function] only. You can save separate home positions for landscape and portrait orientations using  Orientation Linked [:~:~] (P. 210) in  Custom Menu A2.
MF (AF/MF toggle)	<p>Switch between AF and MF. Press once to select MF and again to return to the previous mode. The focus mode can also be selected by holding the button and rotating a dial.</p> <p>This option will have no effect during still photography if [mode2] is selected for  Fn Lever Function] (P. 219). It will likewise have no effect during movie recording if [mode2] is selected for  Fn Lever Function] (P. 163).</p>
RAW  (RAW quality)	<p>Switch between RAW + JPEG and JPEG  settings. Press the control to switch from RAW or JPEG to RAW + JPEG or from RAW + JPEG to JPEG. You can also choose an image quality setting by holding the button and rotating a dial.</p> <ul style="list-style-type: none"> This role is available for  Button Function] only.
Test Picture  TEST)	<p>Take a test shot. You can view the effects of selected settings in an actual photograph. If you keep the control pressed while pressing the shutter button, you will be able to view the results but the picture will not be saved to the memory card.</p> <ul style="list-style-type: none"> This role is available for  Button Function] only.

Role	Function
Custom Mode C1-C4	<p>Recall settings for the selected custom mode. Press the control once to recall saved settings, a second time to restore the settings previously in effect (P. 58). The control continues to perform this function when a custom mode is selected with the mode dial.</p> <ul style="list-style-type: none"> • This role is available for [📷 Button Function] only.
Exposure  	<p>Adjust exposure settings. Hold the control and rotate the front or rear dial. Alternatively, you can press the button to activate settings and then rotate the dials. The adjustments available vary with the shooting mode:</p> <p>[P]: Use the front or rear dial or  on the arrow pad for exposure compensation. Use the   buttons for program shift.</p> <p>[A]: Use the front or rear dial or  on the arrow pad for exposure compensation. Use the   buttons for aperture.</p> <p>[S]: Use the front or rear dial or  on the arrow pad for exposure compensation. Use the   buttons for shutter speed.</p> <p>[M]*: Use the rear dial or   on the arrow pad for shutter speed. Use the front dial or the  buttons for aperture.</p> <p>[B]: Use rear dial or   on the arrow pad to switch between bulb/time and live composite photography. Use the front dial or  buttons to choose the aperture.</p> <p>* For information on adjusting exposure settings when [AUTO] is selected for [ISO] (P. 75, 91), see “Adjusting Exposure Compensation” (P. 68).</p>
Digital Teleconverter 	<p>Turn the digital teleconverter on or off (P. 143). Press once to zoom in and again to zoom out.</p>
Keystone Comp. 	<p>Press the control to view keystone compensation settings (P. 156). After adjusting settings, press the control again to exit. To cancel keystone compensation, press and hold the control.</p> <ul style="list-style-type: none"> • This role is available for [📷 Button Function] only.
Fisheye Compensation 	<p>Enable fisheye correction (P. 242). Press once to enable fisheye correction. Press again to disable. Hold the button and rotate the front or rear dial to choose from [Angle] options 1, 2, and 3.</p> <ul style="list-style-type: none"> • This role is available for [📷 Button Function] only.
Magnify 	<p>Press the control once to display the zoom frame and again to zoom in (P. 73). Press the control a third time to exit zoom; to hide the zoom frame, press and hold the control. Use the multi selector, touch controls, or the arrow pad (  ) to position the zoom frame.</p>

Role	Function
HDR (HDR)	Enable HDR (P. 152). Press once to enable HDR. Press again to disable. Hold the button and rotate the front or rear dial to adjust HDR settings, including HDR bracketing. • This role is available for [ Button Function] only.
BKT (BKT)	Enable bracketing (P. 146). Press once to enable bracketing. Press again to disable. Hold the button and rotate the front or rear dial to adjust [Bracketing] settings. • This role is available for [ Button Function] only.
ISO	Adjust [ISO] settings (P. 75). Hold the control and rotate the front or rear dial. Alternatively, you can press the button to activate settings and then rotate the dials. Use the front or rear dial or on the arrow pad to adjust settings.
WB (white balance)	Adjust [WB] settings (P. 94). Hold the control and rotate the front or rear dial. Alternatively, you can press the button to activate settings and then rotate the dials. Use the front or rear dial or on the arrow pad to adjust settings.
Multi Function	Configure the control for use as a multi-function button (P. 124). Hold the control and rotate the front or rear dial to choose the function performed. The selected function can be performed by pressing the control.
Peaking (PEAK)	Toggle focus peaking on or off (P. 215). Press the control once to turn peaking on and again to turn it off. When peaking is on, peaking options (color, amount) can be displayed by pressing the INFO button.
 Level Disp ()	Display the digital level gauge. The exposure bar display in the viewfinder functions as a level gauge. Press the control again to exit. This option takes effect when [Style 1] or [Style 2] is selected for [EVF Style] (P. 240) in  Custom Menu  .
 View Selection (display selection)	Switch between viewfinder photography and live view. If [Off] is selected for [EVF Auto Switch] (P. 196), the display will switch between the viewfinder and the monitor. Press and hold the control to display [EVF Auto Switch] options.
S-OVF ()	Enable [S-OVF] (P. 197). Press once to turn OVF simulation on. Press again to turn it off. • This role is available for [ Button Function] only.
AF Limiter (AFLimit)	Enable the AF limiter (P. 183). Press once to enable [AF Limiter]. Press again to disable. Hold the button and rotate the front or rear dial to choose from three stored settings. • This role is available for [ Button Function] only.

Role	Function
Preset MF (PreMF)	Toggle [AF Mode] > [Preset MF] on or off (P. 64). Press the control once to enable preset MF and again to restore the previous focus mode. Alternatively, you can choose the [AF Mode] by holding the control and rotating a dial. This option will have no effect during still photography if [mode2] is selected for [Fn Lever Function] (P. 219). It will likewise have no effect during movie recording if [mode2] is selected for [Fn Lever Function] (P. 163).
Lens Info Settings (ExifLens)	Recall previously-saved lens data (P. 239). Recall saved data for the current lens after changing lenses or the like.
IS Mode (IS)	Toggle [Image Stabilizer] on or off (P. 97). Press once to select [Off] and again to turn image stabilization on. Hold the control and rotate the front or rear dial to access [Image Stabilizer] options.
Flicker Scan (Flicker Scan)	Adjust settings for [Flicker Scan] (P. 166, 234). Press the control to select [On]. You can adjust shutter speed for best results while viewing banding in the display. Press the control again to display shooting information and access other settings. Press and hold the control to select [Off] for [Flicker Scan].
Lock (touch control lock)	Lock touch controls. Press and hold the button once to lock touch controls and again to unlock. • This function can be assigned to the \triangleright and \triangleright buttons only. You must first set [\leftrightarrow] to [Direct Function].
Electronic Zoom (W\leftrightarrowT)	Zoom power zoom lenses in or out. After pressing the control, use the arrow pad to zoom in or out. Use Δ or \triangleright on the arrow pad to zoom in and ∇ or \triangleleft to zoom out. • This function can be assigned to the \triangleright and \triangleright buttons only. You must first set [\leftrightarrow] to [Direct Function].
Flash Mode (⚡)	Adjust flash settings (P. 86). Press once to display flash options and again select the highlighted option and exit. Highlight settings using the front or rear dial or \triangleleft on the arrow pad. • This function can be assigned to the \triangleright and \triangleright buttons only. You must first set [\leftrightarrow] to [Direct Function]. • This role is available for [Fn Button Function] only.

Role	Function
 (sequential shooting/self-timer)	Choose a drive (sequential shooting/self-timer) mode (P. 78). Press the button to display drive mode options and then choose a mode using the front or rear dial or the $\triangleleft/\triangleright$ buttons on the arrow pad. <ul style="list-style-type: none"> • This function can be assigned to the <math>\triangleright</math> and <math>\nabla</math> buttons only. You must first set [Fn] to [Direct Function]. • This role is available for [Fn Button Function] only.
Live ND Shooting (NR)	Enable the live ND filter (P. 159). Press once to enable [Live ND Shooting]. Press again to disable. Hold the button and rotate the front or rear dial to adjust [Live ND Shooting] settings. <ul style="list-style-type: none"> • This role is available for [Fn Button Function] only.
 Face Selection (AF)	Select the face used for focus when the camera detects multiple portrait subjects. Pressing the button selects the face closest to the current AF target. If [ALL] (all targets) is selected for AF-target mode, pressing the button will instead select the face closest to the center of the frame. To focus on a different face, hold the button and rotate the front or rear dial. This option can also be used during movie recording.
 Face Priority (FP)	Pressing the button when an option other than [Face Priority Off] is selected for [Face Priority] (P. 92) selects [Face Priority Off]; to restore the previous setting, press the button again. To change the option displayed in the [Face Priority] menu, hold the button and rotate the front or rear dial.
Live View Boost (Boost)	Pressing the button when [Off] is selected for [Live View Boost] (P. 188) selects [On1]. If an option other than [Off] is selected, pressing the button selects [Off]; to restore the previous setting, press the button again. To choose an option for [Live View Boost], hold the control and rotate the front or rear dial. <ul style="list-style-type: none"> • This role is available for [Fn Button Function] only.
Focus Ring Lock (FR)	Press the control once to disable, and again to enable, the lens focus ring. This option is available when [S-AF MF], [C-AF MF], [MF], [C-AF+TR MF], [PreMF], or [AF MF] is selected for [AF Mode]. The MF portion of the AF mode indicator is displayed gray while the ring is disabled. In the case of lenses equipped with an MF (manual focus) clutch, pressing the button has no effect when the focus ring is in the MF position (closer to the camera body). Focus ring lock ends when you perform an operation such as turning the camera off or attaching a different lens.

Role	Function
Movie  ()	Zoom in or out using the movie teleconverter (P. 125). Press the control once to display the zoom frame and again to zoom in. Press the control a third time to exit zoom; to hide the zoom frame, press and hold the control. Use the multi selector, touch controls, or the arrow pad (   ) to position the zoom frame. <ul style="list-style-type: none"> • This role is available for [ Button Function] only.
S-AF	Focus using [S-AF]. Press the control to focus. Focus will lock while the control is pressed. <ul style="list-style-type: none"> • This role is available for [ Button Function] only.
Off	The control is not used.

■ Using multi function options (Multi Function)

Assign multiple roles to a single button.

- To use the multi function feature, you must first assign [Multi Function] to a camera control using [Button Function] (P. 116).

Choosing a function

- Hold the button to which [Multi Function] is assigned and rotate the front or rear dial.
 - Rotate the dial until the desired feature is highlighted. Release the button to select the highlighted feature.
- Press the button to which [Multi Function] is assigned.
- Adjust settings.



The multi-function button can be used to:

Highlight&Shadow Control	Adjust brightness using the front or rear dial. Press the INFO button to choose the tone range (highlights, shadows, or mid-tones).
Color Creator	Use the front dial to adjust hue and the rear dial to adjust saturation.
ISO	Choose a setting using the front or rear dial.
WB	
Magnify	The zoom frame will be displayed.
Image Aspect	Choose a setting using the front or rear dial.
S-OVF	Press the button to turn the feature on or off.
Peaking	

- You can choose the options displayed. Custom Menu **D1** > [Multi Function Settings] (P. 187)

■ Adjusting Zoom During Filming (Movie)

You can zoom in on a selected area of the frame for movie recording without using lens controls. Use for instant close-ups or cuts to wider angle. Buttons or touch controls can be used to choose the zoom location and cut to close ups or wide angles during filming.





[Movie ] is a [Custom Button Function] option. It turns on or off with a button and so must be assigned to a control using [Custom Button Function] (P. 116).

- This feature is not available when [4K] or [C4K] is selected for [Custom Button Function] > [Movie Resolution].
- This feature cannot be used to film high-speed movies.
- [Movie ] cannot be combined with [Digital Tele-converter] (P. 143).

Using [Movie]





- 1 Press the button to which [Movie ] is assigned.
 - A frame will appear in the center of the display.

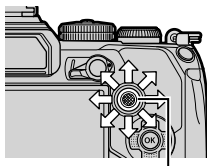

- 2 Position the frame as desired.
 - Position the frame using touch controls, the multi selector, or the arrow pad (   ).
 - To re-center the frame, press the multi selector once or press and hold the  button.



Multi selector

- 3 Press the button to which [Movie ] is assigned once more.
 - The camera will zoom the selected area in to fill the display.
 - To return to the zoom frame, press the button to which [Movie ] is assigned a third time.
- 4 To end zoom, press the  button once, or press and hold the button to which [Movie ] is assigned.

3 Playback

Information display during playback

Playback image information

Simplified display



Overall display

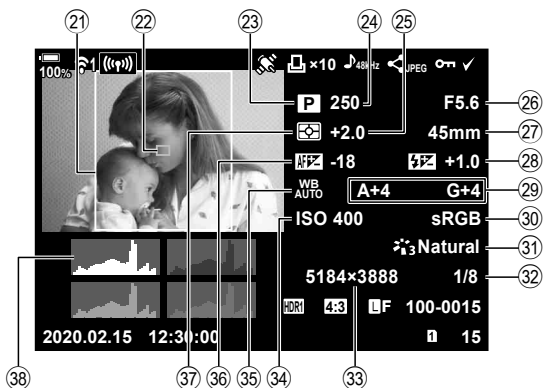

- | | |
|--|--|
| ① Battery level.....P. 32 | ⑲ Live ND filter.....P. 159 |
| ② Wireless LAN connection status.....P. 245, 256 | ⑳ Date and time.....P. 33 |
| ③ Active Bluetooth ® connection.....P. 246 | ㉑ Aspect border.....P. 98 |
| ④ Active connection to computer (Wi-Fi).....P. 256 | ㉒ AF target display.....P. 69 |
| ⑤ Wireless LAN connection.....P. 247, 270 | ㉓ Shooting mode.....P. 41–60 |
| ⑥ GPS data indicator.....P. 254 | ㉔ Shutter speed.....P. 44–50 |
| ⑦ Print order
Number of prints.....P. 134 | ㉕ Exposure compensation.....P. 68 |
| ⑧ Sound record.....P. 136 | ㉖ Aperture value.....P. 44–50 |
| ⑨ Share order.....P. 132 | ㉗ Focal length |
| ⑩ Protect.....P. 131 | ㉘ Flash intensity control.....P. 105 |
| ⑪ Image selected.....P. 133 | ㉙ White balance compensation.....P. 96 |
| ⑫ File number.....P. 195 | ㉚ Color space.....P. 114 |
| ⑬ Frame number | ㉛ Picture mode.....P. 106, 142 |
| ⑭ Playback slot.....P. 237 | ㉜ Compression rate.....P. 236 |
| ⑮ Image quality.....P. 100, 142 | ㉝ Pixel count.....P. 236 |
| ⑯ Aspect ratio.....P. 98 | ㉞ ISO sensitivity.....P. 75, 91 |
| ⑰ HDR image.....P. 152 | ㉟ White balance.....P. 94 |
| ⑱ Focus stacking.....P. 149 | ㊱ Focus adjustment.....P. 183 |
| | ㊲ Metering mode.....P. 77 |
| | ㊳ Histogram |

Switching the information display

You can switch the information displayed during playback by pressing the **INFO** button.

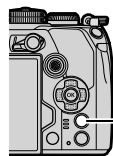

INFO button

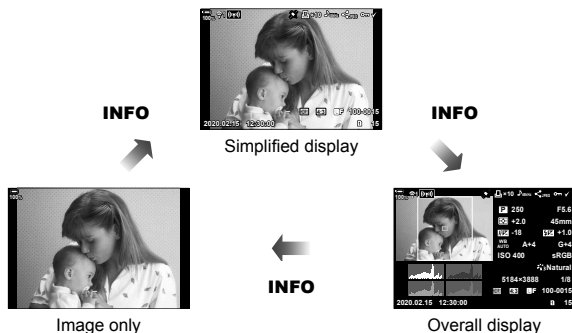





- You can add histogram, highlight & shadow, and Light Box to the information displayed during playback. Custom Menu **01** > /Info Settings > Info (P. 226)

Viewing photographs and movies









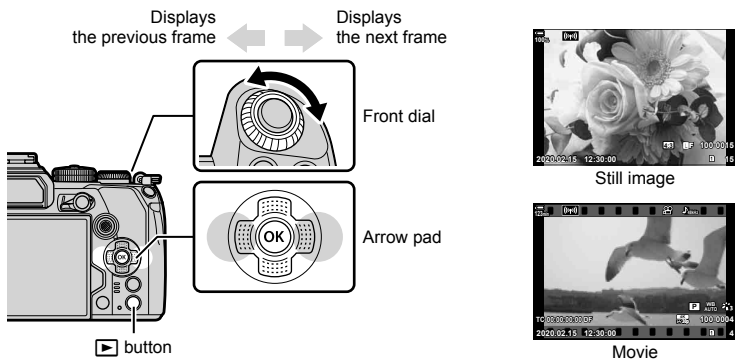











1 Press the button.



- Your most recent photograph or movie will be displayed.
- Select the desired photograph or movie using the front dial or arrow pad.
- Press the shutter button halfway to return to shooting mode.





- The  button can be used to switch between cards while playback is in progress. To choose a card, hold the  button and rotate the front or rear dial. This does not change option selected for [Card Slot Settings] > [ Slot] (P. 237) in  Custom Menu .







Rear dial ()	Zoom in () / Index ()
Front dial ()	Previous () / Next () Operation also available during close-up playback.
Arrow pad () / multi selector ()	Single-frame playback: Next () / previous () / playback volume () Close-up playback: Changing the close-up position <ul style="list-style-type: none"> You can display the next frame () or the previous frame () during close-up playback by pressing the INFO button. Press the INFO button again to display a zoom frame and use    to change its position. Index/calendar playback: Highlight image The above operations can also be performed using the multi selector. <ul style="list-style-type: none"> The operations performed using    can also be performed by pressing the multi selector up, down, left, or right. The operations performed by pressing the INFO button can also be performed by pressing the center of the multi selector.
INFO button	View image info
<input checked="" type="checkbox"/> () button	Select picture (P. 133)

 (AEL/AFL) button	Protect picture (P. 131)
 button	Delete picture (P. 132)
 button	View menus (in calendar playback, press this button to exit to single-frame playback)



Finding Pictures Quickly (Index and Calendar Playback)

- In single-frame playback, rotate the rear dial to  for index playback. Rotate further for calendar playback.
- Turn the rear dial to  to return to single-frame playback.



- You can change the number of frames for index display.   Custom Menu **D1** >  / Info Settings] >  Settings] (P. 228)

Zooming In (Playback Zoom)

In single-frame playback, turn the rear dial to  to zoom in. Turn to  to return to single-frame playback.

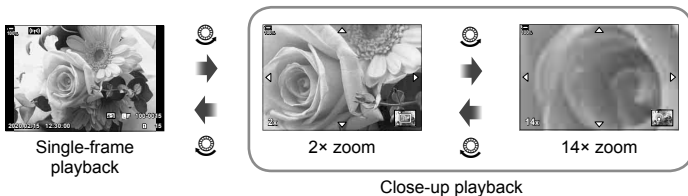

Choose whether to rotate photographs.

- 1 Play the photograph back and press the **OK** button.
- 2 Select [Rotate] and press the **OK** button.
- 3 Press **Δ** to rotate the image counterclockwise, **∇** to rotate it clockwise; the image rotates each time the button is pressed.
 - Press the **OK** button to save settings and exit.
 - The rotated image is saved in its current orientation.
 - Movies and protected images cannot be rotated.



- The camera can be configured to automatically rotate portrait-orientation pictures during playback. **Playback Menu** > [Rotate] (P. 170)
[Rotate] is not available when [Off] is selected for [Rotate].

Watching movies

Select a movie and press the **OK** button to display the playback menu. Select [Play Movie] and press the **OK** button to begin playback. Fast-forward and rewind using **</>**. Press the **OK** button again to pause playback. While playback is paused, use **Δ** to view the first frame and **∇** to view the last frame. Use **</>** or the front dial to view previous or next frame. Press the **MENU** button to end playback.



Viewing Movies over 4 GB in Size

Long movies may exceed 4 GB in size. Movies over 4 GB in size are recorded over multiple files. The files can be played back as a single movie.

- 1 Press the **▶** button.
 - The most recent picture will be displayed.
 - 2 Display a long movie you want to view and press the **OK** button.
 - The following options will be displayed.

[Play from Beginning]:	Plays back a split movie all the way through
[Play Movie]:	Plays back files separately
[Delete entire 🗑️]:	Deletes all parts of a split movie
[Erase]:	Deletes files separately
- We recommend using the latest version of Olympus Workspace to play back movies on a computer (P. 274). Before launching the software for the first time, connect the camera to the computer.

Protecting Pictures



Protect images from accidental deletion. Display the image you want to protect and press the **Protect (AEL/AFL)** button to add **Protect (AEL/AFL)** to the image (protection icon). Press the **Protect (AEL/AFL)** button again to cancel protection. You can also protect multiple selected images. "Selecting Multiple Pictures (**Protect (AEL/AFL)**, Copy Select, Erase Selected, Share Order Selected)" (P. 133)



- Formatting the card erases all data including protected images.
- When an unprotected image is displayed, you can hold the **Protect (AEL/AFL)** button and rotate the front or rear dial to protect all images displayed while the dial is rotated. Any previously-protected images displayed while the dial is rotated will be unaffected.
- When a protected image is displayed, you can hold the **Protect (AEL/AFL)** button and rotate the front or rear dial to remove protection from all images displayed while the dial is rotated. Any previously-unprotected images displayed while the dial is rotated will be unaffected.
- The same operations can be performed during playback zoom or when a picture is selected in the index display.

Copying an image







When there are cards with available space in both slots 1 and 2, you can copy an image to the other card.



- 1 Display an image you want to copy and press the **OK** button.
 - 2 Highlight [Copy] and press the **OK** button.
 - 3 Choose whether to specify the destination folder.
 - If you select [Assign], choose a destination folder.
 - 4 Highlight [Yes] and press the **OK** button.
 - The picture will be copied to the other card.
- You can also copy all images on a card to the other card at a time. Playback Menu > [Copy All] (P. 175)

Deleting Pictures

(Erase)

Display an image you want to delete and press the  button. Select [Yes] and press the  button.

You can erase images without the confirmation step by changing the button settings.   Custom Menu  > [Quick Erase] (P. 196)

- You can choose whether deleting pictures recorded in RAW+JPEG image quality modes deletes both copies, only the JPEG copy, or only the RAW copy.   Custom Menu  > [RAW+JPEG Erase] (P. 196)

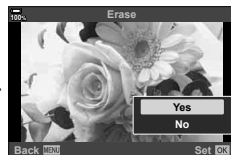
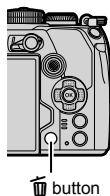









3

Playback

Selecting Pictures for Sharing









(Share Order)

You can select images you want to transfer to a smartphone in advance. When playing back images you want to transfer, press the  button to display the playback menu. Highlight [Share Order], press the  button, and press  or  to mark the image for sharing; a  icon and the file type will be displayed.

To cancel a share order, press  or . You can select images you want to transfer in advance and set a share order all at once.  “Selecting Multiple Pictures (◉, Copy Select, Erase Selected, Share Order Selected)” (P. 133), “Copying Pictures to Smartphones” (P. 251)

- Up to 200 pictures on each slot can be marked for sharing at a time.



- Pictures can also be marked for sharing using the  (◉) button. If the  (◉) button is currently assigned a role other than , assign it the  role using the [◉ Function] option in  Custom Menu  (P. 185).
- When an unmarked image is displayed, you can hold the  (◉) button and rotate the front or rear dial to mark for sharing all images displayed while the dial is rotated. Any previously-marked images displayed while the dial is rotated will be unaffected.
- When a marked image is displayed, you can hold the  (◉) button and rotate the front or rear dial to remove share marking from all images displayed while the dial is rotated. Any previously-unmarked images displayed while the dial is rotated will be unaffected.
- The same operations can be performed during playback zoom or when a picture is selected in the index display.



■ Selecting RAW+JPEG Pictures for Sharing

In the case of pictures recorded with [RAW+JPEG] for image quality, you can choose to share only the JPEG copies, only the RAW copies, or both the JPEG and RAW copies.

- 1 Press the **MENU** button to view the menus.
- 2 Highlight [Wi-Fi/Bluetooth Settings] in the **↓** setup menu and press **▷** on the arrow pad.
- 3 Highlight [RAW+JPEG **↶**] using **△** **▽** and press **▷**.
- 4 Highlight an option using **△** **▽** and press the **OK** button.

JPEG	Only the JPEG copies will be marked for sharing.
RAW	Only the RAW copies will be marked for sharing.
RAW+JPEG	Both RAW and JPEG copies will be marked for sharing.

- Changing the option selected for [RAW+JPEG **↶**] does not affect pictures already marked for sharing.
- Regardless of the option selected, removing share marking removes the marking from both copies.

Selecting Multiple Pictures

(**○**, Copy Select, Erase Selected, Share Order Selected)

You can select multiple images for [**○**], [Copy Select], [Erase Selected] or [Share Order Selected].

Press the **OK** button to display the menu, and then select from [**○**], [Copy Select], [Erase Selected] or [Share Order Selected].

This function is also available in single-frame playback.

- When an unmarked image is displayed, you can hold the **☑** (**○**) button and rotate the front or rear dial to select all images displayed while the dial is rotated. Any previously-marked images displayed while the dial is rotated will be unaffected.
- When a marked image is displayed, you can hold the **☑** (**○**) button and rotate the front or rear dial to deselect all images displayed while the dial is rotated. Any previously-unmarked images displayed while the dial is rotated will be unaffected.



You can save digital “print orders” to the memory card listing the pictures to be printed and the number of copies of each print. You can then have the pictures printed at a print shop that supports DPOF. A memory card is required when creating a print order.

■ Creating a print order

- 1 Press the **OK** button during playback and select **[P]** (Print Order).
- 2 Select **[P]** or **[P]ALL** and press the **OK** button.

Individual picture

Press **<>** to select the frame that you want to set as print reservation, then press **△▽** to set the number of prints.

- To set print reservation for several pictures, repeat this step. Press the **OK** button when all the desired pictures have been selected.



All pictures

Select **[P]ALL** and press the **OK** button.

- 3 Select the date and time format and press the **OK** button.

No	The pictures are printed without the date and time.
Date	The pictures are printed with the shooting date.
Time	The pictures are printed with the shooting time.

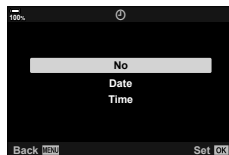













- When printing images, the setting cannot be changed between the images.

- 4 Select **[Set]** and press the **OK** button.
 - The setting will be applied to the images saved on the card being used for playback.
 - The camera cannot be used to modify print orders created with other devices. Creating a new print order deletes any existing print orders created with other devices.
 - Print orders cannot include RAW images or movies.

■ Removing all or selected pictures from the print order

You can reset all print reservation data or just the data for selected pictures.

- 1 Press the  button during playback and select [,] (Print Order).
- 2 Select [,] and press the  button.
 - To remove all pictures from the print order, select [Reset] and press the  button. To exit without removing all pictures, select [Keep] and press the  button.
 - You can also remove all pictures from the print order by selecting [,ALL] and choosing [Reset].
- 3 Press  to select images you wish to remove from the print order.
 - Use  to set the number of prints to 0. Press the  button once you have removed all the desired pictures from the print order.
- 4 Select the date and time format and press the  button.
 - This setting is applied to all frames with print reservation data.
 - The setting will be applied to the images saved on the card being used for playback.
- 5 Select [Set] and press the  button.

Adding Audio to Pictures



You can record audio using the built-in stereo microphone or an optional external microphone and add it to pictures. The recorded audio provides a simple replacement for written notes about the pictures.

- Audio recordings can be up to 30 s long.

- 1 Display the image to which you want to add audio and press the **OK** button.
 - Audio recording is not available with protected images.
 - Audio can also be added to pictures using the [Edit] option in the playback menu. Use [Edit] > [Sel. Image] to select the picture, then press the **OK** button and select **[M]**.
- 2 Select **[M]** and press the **OK** button.
 - To exit without adding audio, select [No].



- 3 Select **[M Start]** and press the **OK** button to begin recording.
- 4 Press the **OK** button to end recording.
 - Pictures with audio are indicated by icons and indicators showing the recording rate.
 - To delete recorded audio, select [Erase] in Step 3.

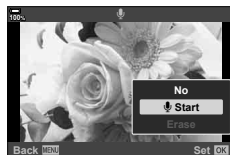

- Audio is recorded at the rate selected for movies. The rate can be selected using [Movie] (P. 169) in the video menu.

■ Audio Playback

Playback begins automatically when a picture with audio is displayed. To adjust the volume:

- 1 Press the **▶** button to display a picture.
- 2 Press **△** or **▽** on the arrow pad.
 - **△** button: Raise volume.
 - **▽** button: Lower volume.



Playback Using Touch Controls

Use touch controls to zoom pictures in and out, scroll pictures, or choose the picture displayed.



■ Full-frame playback

Displaying the previous or next image

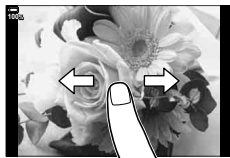
- Slide your finger to the left to view the next image, and right to view the previous image.









■ Magnify

- Lightly tap the screen to display the slider and .
- Slide the bar up or down to zoom in or out.
- Slide your finger to scroll the display when the picture is zoomed in.
- Tap  to display index playback.
- Tap  for calendar playback.



■ Index/Calendar playback

Displaying the previous or next page

- Slide your finger up to view the next page, and down to view the previous page.
- Tap  or  to switch the number of images displayed.  Custom Menu  > /Info Settings] >  Settings] (P. 228)
- Tap  several times to return to single-frame playback.

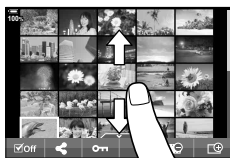





■ Viewing images

- Tap an image to view it full frame.

Selecting and protecting images

In single-frame playback, lightly tap the screen to display the touch menu. You can then perform the desired operation by tapping the icons in the touch menu.

	Select an image. You can select multiple images and delete them collectively.
	Images you want to share with a smartphone can be set.  “Selecting Pictures for Sharing (Share Order)” (P. 132)
	Protects an image.

- Do not tap the display with your fingernails or other sharp objects.
- Gloves or monitor covers may interfere with touch screen operation.

4 Menu functions

Basic menu operations

The menus contain shooting and playback options that are not displayed by the LV super control panel, etc., and let you customize the camera settings for easier use.

Tab	Tab name	Description
	Shooting Menu 1	Photography-related items. Ready the camera for shooting or access basic photo settings.
	Shooting Menu 2	Photography-related items. Adjust advanced photo settings.
	Video Menu	Items related to movie recording. Adjust basic and custom settings.
	Playback Menu	Playback- and retouch-related items.
	Custom Menu	Items for customizing the camera.
	Setup Menu	Items for setting the clock, choosing a language, and the like.
	My Menu*	A customizable menu containing only items you select.

* "My Menu" contains no items at shipment. Use "My Menu" to store and organize frequently-used items from other menus. Select items for addition to "My Menu" from the camera menus (P. 179).

1 Press the **MENU** button to display the menus.

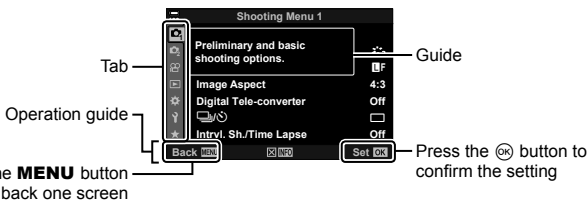

- A guide is displayed about 2 seconds after you select an option. Press the **INFO** button to view or hide guides.

2 Use Δ / ∇ to select a tab and press the **OK** button.

- The menu group tab appears when the **Custom Menu** is selected. Use Δ / ∇ to select the menu group and press the **OK** button.

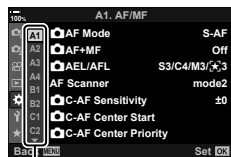

Menu group

- 3 Select an item using Δ ∇ and press the OK button to display options for the selected item.

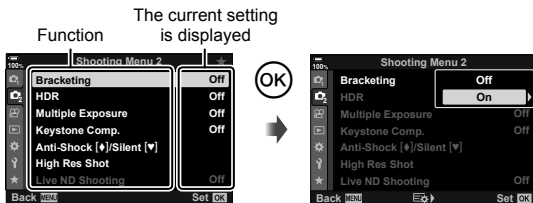

- 4 Use Δ ∇ to highlight an option and press the OK button to select.

- Press the **MENU** button repeatedly to exit the menu.

- For the default settings of each option, refer to “Default Settings” (P. 301).
- Depending on camera status and settings, some items may be unavailable. Items that are not available are grayed out and cannot be selected.
- You can also navigate the menus using the multi selector or the front and rear dials in place of the arrow pad.

Using Shooting Menu 1/Shooting Menu 2



Shooting Menu 1

- 1 Reset / Custom Modes (P. 141)
- Picture Mode (P. 106, 142)
- (P. 100, 142)
- Image Aspect (P. 98)
- Digital Tele-converter (P. 143)
- (drive) (P. 78, 80)
- Intrvl. Sh./Time Lapse (P. 144)

Shooting Menu 2

- 2 Bracketing (P. 146)
- HDR (P. 152)
- Multiple Exposure (P. 154)
- Keystone Comp. (P. 156)
- Anti-Shock /Silent (P. 157)
- High Res Shot (P. 158)
- Live ND Shooting (P. 159)

Restoring Default Settings (Reset)

Camera settings can be easily restored to default settings. You can opt to reset almost all settings or only those directly related to photography.

- 1 Select [Reset / Custom Modes] in Shooting Menu 1 and press the button.
 - 2 Select [Reset] and press the button.
- 
- 3 Highlight [Full] or [Basic], and press the button.
 - To reset all settings except the time, date, and a few others, highlight [Full] and press the button. "Default Settings" (P. 301)
 - 4 Press the button in the [Reset / Custom Modes] menu.
 - 5 Select [Yes] and press the button.

Saving Settings

(Assign to Custom Mode)



Frequently-used settings and shooting modes can be saved to custom modes (C1 through C4) and recalled for use as required simply by rotating the mode dial. Saved settings can also be recalled directly from the menus.  “Recalling Saved Settings” (P. 58)

- At default settings, custom modes are equivalent to mode P.

Processing options

(Picture Mode)

You can make individual adjustments to contrast, sharpness and other parameters in [Picture Mode] (P. 106) settings. Changes to parameters are stored for each picture mode separately.

- 1 Select [Picture Mode] in  Shooting Menu 1 and press the  button.
 - The camera will display the picture mode available in the current shooting mode.

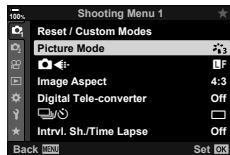

- 2 Select an option with   and press the  button.

- Press  to set the detailed options for the selected picture mode. Detailed options are not available for some picture modes.
- Changes to contrast have no effect at settings other than [Normal].









- You can reduce the number of picture mode options displayed in the menu.
  Custom Menu  > [Picture Mode Settings] (P. 187)

Photo File and Image Size Options



 

 “Photo File and Image Size Options ( )” (P. 100)



- You can change the JPEG image size and compression ratio combination, and [M] and [S] pixel counts. [ Set], [Pixel Count]  “Combinations of JPEG image sizes and compression rates ( Set)” (P. 236)

Shooting automatically with a fixed interval (Intrvl. Sh./Time Lapse)

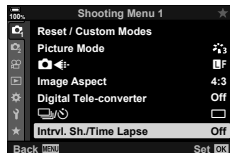

You can set the camera to shoot automatically with a set time lapse. The shot frames can also be recorded as into a single movie. This setting is only available in **P/A/S/M** modes.

- 1 Select [Intrvl. Sh./Time Lapse] in  Shooting Menu 1 and press the  button.



- 2 Select [On] and press .
- 3 Adjust the following settings and press the  button.

Number of Frames	Choose the number of frames shot.
Start Waiting Time	Choose how long the camera waits before starting interval timer photography and taking the first shot.
Interval Length	Choose how long the camera waits between shots once shooting has begun.
Time Lapse Movie	Choose whether to record a time-lapse movie. [Off]: The camera saves the individual shots but does not use them to create a time-lapse movie. [On]: The camera records the individual shots and also uses them to create a time-lapse movie.
Movie Settings	Choose the frame size ([Movie Resolution]) and frame rate ([Frame Rate]) for movies created using [Time Lapse Movie].

- 4 Press the  button repeatedly to return to  Shooting Menu 1.

- Press the **MENU** button to exit the menus.
- A  icon will appear in the shooting display (the icon shows the selected number of shots).

Interval-timer photography



- 5 Take pictures.

- The  icon will turn green and the number of shots remaining will be displayed.
- Frames are shot even if the image is not in focus after AF. If you wish to fix the focus position, shoot in MF.
- [Rec View] (P. 176) starts in 0.5 seconds.

- If the time until shooting or the shooting interval is 1 minute 31 seconds or longer, the monitor will go dark and the camera will enter sleep mode if no operations are performed for 1 minute. The camera and monitor will reactivate automatically 10 seconds before a picture is taken, and can be reactivated manually by pressing the shutter button.
- The camera automatically selects [S-AF] for AF mode (P. 64) in place of [C-AF] and [C-AF+TR], and [S-AF **MF**] in place of [C-AF **MF**] and [C-AF+TR **MF**].
- When [**S**AF] is selected as the AF mode, focus to initiate shooting, then lock focus and start recording.
- Touch operations are disabled during time lapse shooting.
- Time-lapse shooting cannot be combined with bracketing, multiple exposure, HDR, or the live ND filter.
- The flash will not work if the flash charging time is longer than the interval between shots.
- Choosing a value over 1000 for [Number of Frames] selects [Off] for [Time Lapse Movie].
- If any of still pictures are not recorded correctly, the time lapse movie will not be generated.
- If there is insufficient space on the card, the time lapse movie will not be recorded.
- Time lapse shooting will be canceled if any of the following is operated:
Mode dial, **MENU** button,  button, lens release button, or connecting the USB cable.
- Turning the camera off ends interval-timer photography.
- If there is not enough charge left on the battery, the shooting may end partway through. Make sure the battery is charged enough before shooting.
- Time-lapse movies created at a size of [4K] may not display on some computer systems. More information is available on the OLYMPUS website.

Varying settings over a series of photographs (Bracketing)

Bracketing is used to vary shooting settings such as exposure and white balance over a series of shots. Depending on the setting, you may be able to combine several different forms of bracketing. Use bracketing if you are unsure what settings to use or lack the time needed to change settings during shooting. You can also store bracketing settings and later recall them simply by turning bracketing on.

AE BKT (AE bracketing)

The camera varies the exposure of each shot. You can select the bracketing increment from 0.3 EV, 0.7 EV, and 1.0 EV. In single-frame shooting mode, one photograph is taken each time the shutter button is pressed all the way down, while in sequential shooting mode the camera continues to take shots in the following order while the shutter button is pressed all the way down: no modification, negative, positive.

- Number of shots: Choose from 2, 3, 5, or 7.
- A **[BKT]** icon is displayed in green until all the shots in the bracketing sequence have been taken.
- The camera modifies exposure by varying aperture and shutter speed (mode **P**), shutter speed (mode **A**), aperture (mode **S**), or ISO sensitivity (mode **M**).
- If an option other than [AUTO] is selected for [ISO] (P. 75, 91) in mode **M**, the camera will instead modify exposure by varying shutter speed.
- The camera brackets the value currently selected for exposure compensation.
- The size of the bracketing increment changes with the value selected for [EV Step] (P. 191).
- Exposure bracketing cannot be combined with FL or focus bracketing.

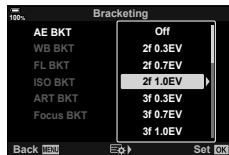

WB BKT (WB bracketing)

Three images with different white balances (adjusted in specified color directions) are automatically created from one shot, starting with the value currently selected for white balance.

- White balance can be varied by 2, 4, or 6 steps on each of the A-B (Amber-Blue) and G-M (Green-Magenta) axes.
- The camera brackets the value currently selected for white balance compensation.
- WB bracketing cannot be combined with ART or focus bracketing.



FL BKT (FL bracketing)

The camera varies flash level over three shots (no modification on the first shot, negative on the second, and positive on the third). The amount can be chosen from 0.3, 0.7, and 1.0 EV. In single-frame shooting mode, one photograph is taken each time the shutter button is pressed all the way down, while in sequential shooting mode the camera continues to take shots in the following order while the shutter button is pressed all the way down: no modification, negative, positive.

- A **[BKT]** icon is displayed in green until all the shots in the bracketing sequence have been taken.
- The size of the bracketing increment changes with the value selected for [EV Step] (P. 191).
- Flash bracketing cannot be combined with AE or focus bracketing.

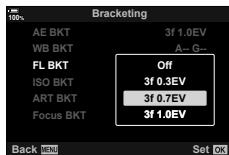

ISO BKT (ISO bracketing)

The camera varies the sensitivity over three shots while keeping the shutter speed and aperture fixed. You can select the bracketing increment from 0.3 EV, 0.7 EV, and 1.0 EV. Each time the shutter button is pressed, the camera shoots three frames with the set sensitivity (or if auto sensitivity is selected, the optimal sensitivity setting) on the first shot, negative modification on the second shot, and positive modification on the third shot.

- The size of the bracketing increment does not change with the value selected for [ISO Step] (P. 191).
- Bracketing is performed regardless of the upper limit set with [ISO-Auto Set] (P. 191).
- During silent photography, the flash sync speed is set to 1/20 s.
- ISO sensitivity bracketing cannot be combined with ART or focus bracketing.

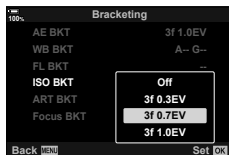

ART BKT (ART bracketing)

Create multiple copies of each picture, each with a different art filter (picture mode) applied. The options selected are indicated by checks (✓).

- With the exceptions of AE and FL bracketing, ART bracketing cannot be combined with other forms of bracketing.

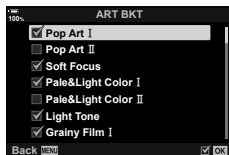

Focus BKT (Focus bracketing)

Take a series of shots at different focus positions. Focus moves successively farther from the initial focus position. Choose the number of shots using [Set number of shots] and the change in focus distance using [Set focus differential]. Choose smaller values for [Set focus differential] to narrow the change in focus distance, larger values to widen it. If you are using a flash other than the dedicated flash unit, you can specify the time it takes to charge using the [⚡ Charge Time] option.

Press the shutter button all the way down and release it immediately. Shooting will continue until the selected number of shots is taken or until the shutter button is pressed all the way down again.

- Focus bracketing is not available with lenses that have mounts conforming to the Four-Thirds standard.
- Focus bracketing ends if zoom is adjusted during shooting.
- Shooting ends when focus reaches infinity.
- Pictures taken using focus bracketing are shot in silent mode.
- To use the flash, select [Allow] for [Silent [♥] Mode Settings] (P. 157) > [Flash Mode].
- Focus bracketing cannot be combined with other forms of bracketing.
- The flash sync speed is set to 1/50 s. Selecting a value over ISO 8000 for [📷 ISO] sets the flash sync speed to 1/20 s.
- Olympus Workspace can be used to stack [Focus BKT] pictures taken using lenses that support [Focus Stacking].
- See the OLYMPUS website for information on the lenses that can be used with [Focus Stacking].

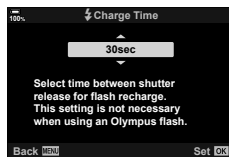
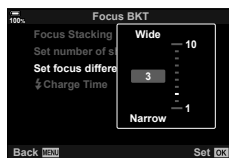
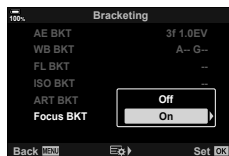

Focus BKT (Focus Stacking)

The camera automatically shifts focus over a series of from 3 to 15 shots and combines to create a single JPEG image that is in focus all the way from the foreground to background.

The camera automatically takes 3 to 15 shots bracketing the current focus position.

- If focus stacking fails, the camera will record the selected number of photos without creating a composite image.
- Shooting will end if zoom is adjusted after the shutter button has been pressed all the way down to start focus stacking photography.
- The angle of view for composited images is narrower than the original images.
- A frame indicating the final crop will be shown in the display. Compose the shot with your subject in the frame.
- Guide line selected in [Displayed Grid] (P. 189) will not be displayed.
- Pictures taken with [e-Portrait] or an art filter selected for picture mode are recorded in [Natural] mode.
- See the OLYMPUS website for information on the lenses that can be used with [Focus Stacking].
- Focus stacking cannot be combined with other forms of bracketing.

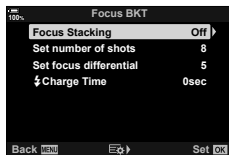

Using Bracketing

- 1 Select [Bracketing] in Shooting Menu 2 and press the button.
- 2 After selecting [On], press and select a bracket shooting type.
 - A menu of bracketing types will be displayed.
- 3 Highlight a bracketing type using the buttons and press the button.
 - The camera will display bracketing options for the selected bracketing type.

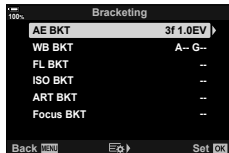
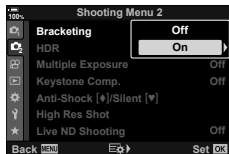
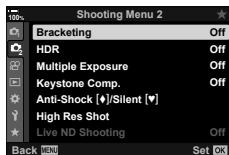

4 Using the Δ ∇ \triangleleft \triangleright buttons, select [On] or a bracketing program.

- **AE BKT**

Highlight the number of shots (for example, 2f) and press the \triangleright button to view bracketing amounts. Use the Δ ∇ buttons to highlight an amount and press \odot to select the highlighted option and return to the previous display.

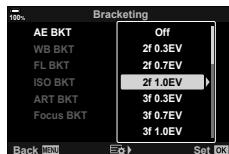

- **WB BKT**

You will be prompted to choose a color axis (A–B or G–M). Use the \triangleleft \triangleright buttons to highlight an axis and the Δ ∇ buttons to choose the bracketing amount. Press the \odot to return to the previous display when settings are complete.



- **ART BKT**

Highlight [On] and press the \triangleright button to display a menu of picture modes and art filters. Use the Δ ∇ buttons to highlight the desired filters and press the \odot button to select (selected filters are indicated by check marks). Press the **MENU** button to return to the previous display when settings are complete.

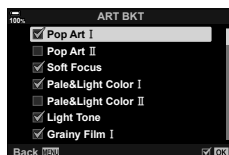

- **Focus BKT**

Highlight [On] and press the \triangleright button to view focus bracketing settings. Use the Δ ∇ buttons to highlight a setting and press the \triangleright button to display options. Use the Δ ∇ buttons to highlight an option and press the \odot button to return to the setting menu. Press the \odot button again to return to the bracketing menu when settings are complete. The [Focus BKT] menu is also used for [Focus Stacking] settings (P. 149).



5 With [On] selected, press the \odot button to save changes and exit.

6 Confirm that [On] is selected for [Bracketing] and press the \odot button.

- To save changes without enabling bracketing, press the **MENU** button or highlight [Off] and press the \odot button.



7 Take pictures.

- A **[BKT]** icon is displayed when bracketing is active.

- Bracketing cannot be combined with HDR, interval-timer photography, keystone compensation, multiple-exposure photography, High Res Shot, fisheye compensation, or the live ND filter.
- Bracketing is not available if there is not enough space on the camera's memory card for the selected number of frames.
- AE, FL, and focus bracketing are not available in mode **B**.





- [BKT] can be assigned to a camera control, which can then be used to enable or disable bracketing, choose the bracketing type, or adjust bracketing settings.  "Assigning functions to buttons (Button Function)" (P. 116)





Taking HDR (High Dynamic Range) images (HDR)

The camera varies exposure over a series of shots, selects from each tone range with the highest level of detail, and combines them to create a single picture with a wide dynamic range. If the photo features a high-contrast subject, details that would otherwise be lost in shadows or highlights will be preserved.

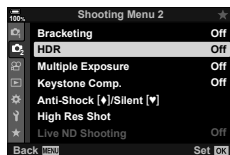
- This option is available in **P**, **A**, **S**, and **M** modes.

- 1 Press the **MENU** button to display the menus.
- 2 Highlight [HDR] in  Shooting Menu 2 and press  on the arrow pad.



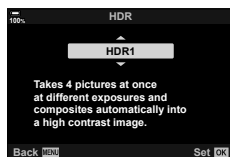

- 3 Highlight an option using the   buttons and press the  button.
 -  Shooting Menu 2 will be displayed.

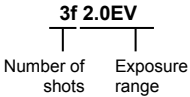

HDR1	Each time you take a photo, the camera will take a series of shots while varying exposure and combine them into a single picture. Choose [HDR1] for natural-looking results, [HDR2] for a more painterly effect. <ul style="list-style-type: none"> •  ISO is fixed at ISO 200.
HDR2	<ul style="list-style-type: none"> • Shutter speeds can be as slow as 4 s. Shooting will continue for up to 15 s. • Picture mode is fixed at [Natural] and color space at [sRGB]. • The combined picture is saved in JPEG format. If [RAW] is selected for image quality, it will instead be recorded in RAW + JPEG format.
3f 2.0EV	<p>Each time you take a photo, the camera will vary exposure over a series of shots. The shots are not combined to create a single picture. The shots can however be combined using HDR software on a computer or other device.</p> <div style="text-align: center;"> <p>3f 2.0EV</p>  <p>Number of shots Exposure range</p> </div>
5f 2.0EV	
7f 2.0EV	
3f 3.0EV	
5f 3.0EV	

- 4 Press the **MENU** button repeatedly to exit the menus.

- The camera will return to the shooting display. An  icon will be displayed.
- The drive mode will be fixed at  (sequential high).



5 Take pictures.

- Each time you press the shutter button, the camera will take the selected number of shots.
- In [HDR1] and [HDR2] modes, the camera will automatically combine the shots into a single picture.
- Exposure compensation is available in modes **P**, **A**, and **S**.
- In mode **M**, the camera takes the values selected for aperture and shutter speed as a base for HDR photography.
- Use a tripod or take similar measures to fix the camera in place.
- The image displayed in the monitor or viewfinder during shooting differs from the final HDR picture.
- Noise may appear in the final picture when a slower shutter speed is selected in [HDR1] or [HDR2] mode.
- The following cannot be used:
 - flash photography, bracketing, multiple exposure, interval-timer photography, keystone compensation, the live ND filter, fisheye correction, and High Res Shot.



- [HDR] can be assigned to a button. You then need only press the button to enable it.
 - ▶ “Assigning functions to buttons (Button Function)” (P. 116)

Recording multiple exposures in a single image

(Multiple Exposure)

Take two shots and combine them into a single picture. Alternatively, you can take a shot and combine it with an existing picture stored on the memory card.

The combined image is recorded at current image quality settings. Only RAW pictures can be selected for multiple exposures that include an existing image.

If you record a multiple exposure with RAW selected for [RAW], you can then select it for subsequent multiple exposures using [Overlay], allowing you to create multiple exposures combining three or more photographs.

- This option is available in **P**, **A**, **S**, **M**, and **B** modes.

- 1 Select [Multiple Exposure] in **C2** Shooting Menu 2 and press the **OK** button.
- 2 Use Δ ∇ to select the item and press **▷**.
 - Use Δ ∇ to select the setting and press the **OK** button.

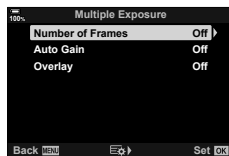

Number of Frames	[Off]: Do not create additional multiple exposures. [2f]: Create a multiple exposure from 2 pictures.
Auto Gain	[On]: Halve the brightness of each picture in the multiple exposure. [Off]: Do not adjust brightness the brightness of the pictures in the multiple exposure.
Overlay	[On]: Shoot a multiple exposure that includes an existing RAW image stored on the memory card. [Off]: Create a multiple exposure from the next 2 pictures taken. <ul style="list-style-type: none">• [Overlay] is only available when [2f] is selected for [Number of Frames].

- 3 If [On] is selected for [Overlay], you will be prompted to choose a picture for the multiple exposure.
 - Highlight a picture using the arrow pad (Δ ∇ \triangleleft \triangleright) and press the **OK** button.
 - Only RAW images can be selected.
- 4 Press the **OK** button in the multiple exposure menu to save the selected settings.
 - The shooting menu will be displayed.

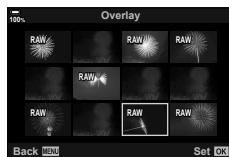



5 Press the **MENU** button to exit the menus.



- A  icon will be displayed.
- If [Overlay] is selected, the chosen photograph will be visible superimposed on the view through the lens.



6 Take pictures.

- The first shot (or if [Overlay] is selected, the previously-chosen photograph) will be visible superimposed on the view through the lens as you compose the next shot.
- The  icon turns green.
- Normally, a multiple exposure will be created after the second shot is taken.
- Pressing the  button allows you to retake the first shot.
- If [On] is selected for [Overlay], you can take additional pictures that will be overlaid on the previously-chosen photograph.

7 Press the **MENU** button or press the button to end multiple exposure photography.

- If you end multiple exposure photography by pressing the **MENU** button, [Off] will be selected for [Number of Frames] in the multiple exposure menu.
- The  icon clears from the display when multiple exposure photography ends.
- The camera will not enter sleep mode during multiple exposure photography.
- Pictures taken with other cameras cannot be used for multiple exposures.
- RAW pictures taken using High Res Shot cannot be used for multiple exposures.
- The RAW pictures listed in the image-selection display when [On] is selected for [Overlay] are those processed using the settings in effect at the time the photograph was taken.
- Exit multiple exposure mode before adjusting shooting settings. Some settings cannot be adjusted while multiple exposure mode is in effect.
- Performing any of the following operations after the first shot is taken ends multiple exposure photography:
 - turning the camera off, pressing the  or **MENU** button, choosing a different shooting mode, or connecting cables of any type. Multiple exposure is also canceled when the battery is exhausted.
- The image-selection display for [Overlay] shows the JPEG copies of photographs taken with RAW + JPEG selected for image quality.
- Live composite photography ([LIVE COMP]) is not available in mode **B**.
- The following are not available in multiple exposure mode:
 - HDR, bracketing, interval-timer photography, keystone compensation, the live ND filter, fisheye correction, and High Res Shot.
- Pictures taken with RAW selected for  can also be overlaid during playback.

Keystone correction and perspective control (Keystone Comp.)

Keystone distortion due to the influence of lens focal length and proximity to the subject can be corrected, or enhanced to exaggerate the effects of perspective. Keystone compensation can be previewed in the monitor during shooting. The corrected image is created from a smaller crop, slightly increasing the effective zoom ratio.

- This option is available in **P**, **A**, **S**, **M**, and **B** modes.

- 1 Select [Keystone Comp.] in **2** Shooting Menu 2, and press the **OK** button.
- 2 Highlight [On], and press the **OK** button.
- 3 Press the **MENU** button to exit the menus.
 - The camera will switch to the keystone compensation display. A slider and **Keystone Comp.** icon be displayed.

Keystone compensation

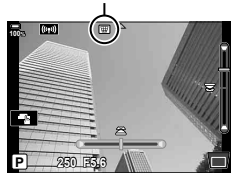

- 4 Frame the shot and adjust keystone compensation while viewing your subject in the display.
 - Rotate the front dial to make horizontal adjustments and the rear dial to make vertical adjustments.
 - Frame the shot and adjust keystone compensation while viewing your subject in the display.
 - Use the arrow pad (**Δ** **▽** **<** **>**) to position the crop. The direction in which the crop can be moved is shown by an arrow (**▲**).
 - To cancel changes, press and hold the **OK** button.
- 5 To adjust aperture, shutter speed, and other shooting settings, press the **INFO** button.
 - Standard shooting indicators will be displayed.
 - A **Keystone Comp.** icon is displayed while keystone compensation is enabled. The icon is displayed in green if adjustments have been made to keystone compensation settings.
 - To return to the keystone compensation display shown in Step 4, press the **INFO** button repeatedly.
- 6 Take pictures.
 - Pictures may seem "grainy" depending on the amount of compensation performed. The amount of compensation also determines the amount the picture will be enlarged when cropped and whether the crop can be moved.
 - Depending on the amount of compensation, you may be unable to reposition the crop.
 - Depending on the amount of compensation performed, the selected AF target may not be visible in the display. If the AF target is outside the frame, its direction is indicated by a **▲**, **▼**, **◀**, or **▶** icon in the display.

- Pictures taken with [RAW] for image quality are recorded in RAW + JPEG format.
- The following cannot be used:
 - live composite photography, burst photography, bracketing, HDR, multiple exposure, the live ND filter, fish-eye correction, the digital teleconverter, movie recording, [C-AF], [C-AF MF], [C-AF+TR], and [C-AF+TR MF] AF modes, [e-Portrait] and art filter picture modes, the custom self-timer, and High Res Shot.
- Lens converters may not produce the desired results.
- Be sure to provide [Image Stabilizer] data for lenses that are not part of the Four Thirds or Micro Four Thirds family (P. 97).
- Where applicable, keystone compensation will be performed using the focal length supplied for [Image Stabilizer] (P. 97) or [Lens Info Settings] (P. 239).



- [Keystone Comp.] can be assigned to a button. You then need only press the button to enable keystone compensation. "Assigning functions to buttons (Button Function)" (P. 116)

Setting anti-shock/silent shooting (Anti-Shock [♦]/Silent [♥])









By setting anti-shock (P. 80)/silent shooting (P. 81), you can select anti-shock or silent shooting when using sequential shooting/self-timer (P. 78).



- 1 Select [Anti-Shock [♦]/Silent [♥]] in Shooting Menu 2 and press the button.
- 2 Use to select the item and press .
 - Use to select the setting and press the button.

Anti-Shock [♦]	Choose the delay between the shutter button being pressed all the way down and the shutter being released in anti-shock mode. Use this mode to suppress small vibrations caused by the operation of the shutter. Anti-shock mode is available in both sequential shooting and self-timer modes (P. 78). Select [Off] to disable anti-shock mode when it is not in use.
Silent [♥]	Choose the delay between the shutter button being pressed all the way down and the shutter being released in silent mode. Use this option in settings in which the sound of the shutter would be unwelcome. Silent mode supports both the self-timer and sequential shooting (P. 78). Select [Off] to disable silent mode when it is not in use.
Noise Reduction [♥]	Select [Auto] to reduce image "noise" in long exposures during silent photography. The sound of the shutter may be audible when noise reduction is active.
Silent [♥] Mode Settings	Choose whether to enable [●]), [AF Illuminator], or [Flash Mode] in silent mode. Select [Allow] to use current settings for the selected item, [Not Allow] to ignore current settings and disable the selected item.

Setting high resolution shooting (High Res Shot)

By specifying the setting for [High Res Shot] (P. 83), high resolution shooting can be activated by selecting  from options for sequential shooting/self-timer mode (P. 78).

- 1 Select [High Res Shot] in  Shooting Menu 2 and press the  button.
- 2 Use   to select the item and press .
 - Use   to select the setting and press the  button.



High Res Shot	Choose how long the camera waits to begin shooting after the shutter button is pressed all the way down. Use this option to prevent blur caused by the camera moving when the shutter button is pressed. Select [Off] to disable High Res Shot.
 Charge Time	Choose how long the camera waits for the flash to charge for High Res Shots taken with the flash. You need not specify a value when using an external flash.
Shooting Method	[Tripod]: Take photos with the camera on a tripod or otherwise secured. RAW pictures are recorded at a size of 80 megapixels (10368×7776). <ul style="list-style-type: none">• The flash sync speed is 1/50 s.• The maximum value for  ISO is 1600. [Handheld]: Take hand-held shots. The camera takes slightly longer to record pictures. RAW pictures are recorded at a size of 50 megapixels (8160×6120). <ul style="list-style-type: none">• The flash is disabled.• The maximum value for  ISO is 6400.

- Electronic shutter is used for high resolution shooting.



Slowing the Shutter in Bright Light (Live ND Shooting)

The camera makes a series of exposures and combines to create a single photo that appears to have been taken at a slow shutter speed.



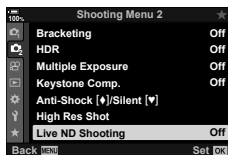



- This option is available in modes **S** and **M**.
- Changing exposure compensation or shutter speed resets the [LV Simulation] display.

- 1 Highlight [Live ND Shooting] in  Shooting Menu 2 and press the  button.





- 2 Highlight [On] using the   buttons and press the  button.



- 3 Use   to select the item and press .
 - Use   to select the setting and press the  button.



ND Number	Choose an ND filter type; the camera will convert it to an exposure value and reduce exposure by that amount. Options are available in increments of 1 EV: [ND2 (1EV)], [ND4 (2EV)], [ND8 (3EV)], [ND16 (4EV)], [ND32 (5EV)]
LV Simulation	Choose whether to preview the effect of the selected filter at the current shutter speed. [On]: The effects of shutter speed are shown in the display. [Off]: Use the standard shooting display.

- 4 To take pictures using the live ND filter, highlight [On] and press the  button, or select [Off] to proceed without enabling the live ND filter.
 -  Shooting Menu 2 will be displayed.







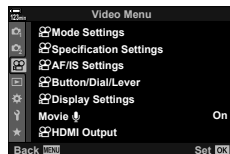















Using the Video Menu













Movie recording functions are set in the Video Menu.



Option	Description	
Mode Settings	Adjust settings for movie recording.	—
Mode	Choose a movie record mode.	165
Flicker Scan	Select [On] to reduce flicker caused by LED lighting. Rotate the front or rear dial or use Δ ∇ on the arrow pad to choose the shutter speed at which flicker reduction applies.	166
Specification Settings	Adjust image quality for movies.	—
ISO	Choose the image quality size and bit rate.	167
ISO-Auto Set	[Upper Limit / Default]: Choose the maximum and standard ISO sensitivity values available to auto ISO sensitivity control when [AUTO] is selected for [ISO] in [Mode] (movie exposure mode) [M]. [ISO-Auto]: [AUTO] is available for [ISO] when [M] is selected for [Mode] (movie exposure mode). Auto ISO sensitivity control settings can be adjusted using [Upper Limit / Default].	75
Noise Filter	Select a noise reduction level for recording high-sensitivity movies.	—
WB	Choose a white balance mode for movie recording.	94
All WB	Fine-tune white balance across the board. [All Set]: Fine-tune white balance for all modes. [All Reset]: Reset fine-tuning for all modes to default values.	96
WB AUTO Keep Warm Color	Choose [On] to preserve warm colors in movies shot under incandescent lighting when [AUTO] is selected for white balance.	94, 96
Picture Mode	Choose [On] to enable selection of a picture mode specifically for use when recording movies.	106









Option	Description	
 AF/IS Settings	Choose focus and image stabilization settings for use when recording movies.	—
 AF Mode	Choose the AF mode for movie recording.	64, 91
 C-AF Speed	Choose how quickly the camera responds to changes to the distance to subject when [C-AF] or [C-AF+TR] is selected for focus mode.	—
 C-AF Sensitivity	<p>Choose how rapidly the camera responds to changes in the distance to the subject while focusing with [C-AF] or [C-AF+TR] selected for  AF Mode]. This can help autofocus track a quickly-moving subject or prevent the camera refocusing when an object passes between the subject and the camera.</p> <ul style="list-style-type: none"> • Choose from three levels of tracking sensitivity. • Select +1 for increased sensitivity. Choose this option for subjects that are moving toward or away from the camera or changing speed unpredictably or for subjects that suddenly enter the frame. • Select -1 for reduced sensitivity. Choose this option to prevent the camera refocusing when the subject is briefly obscured by other objects or to prevent the camera focusing on the background when you are unable to keep the AF target positioned over a quickly-moving subject. 	—
 Image Stabilizer	Adjust image stabilization settings for movie recording.	97
 IS Level	<p>Choose the amount of image stabilization applied.</p> <p>[+1]: Choose for static hand-held shots.</p> <p>[±0]: Recommended in most situations.</p> <p>[-1]: Choose for hand-held panning, tilting, or tracking shots.</p>	—



Option	Description	
 Button/Dial/Lever	Choose the roles played by camera buttons, dials, and levers in movie mode.	—
 Button Function	Choose the roles played by camera buttons in movie mode.	116
 Dial Function	Choose the roles played by front and rear dials in movie mode.	168
 Fn Lever Function	Choose the functions that can be selected using the Fn lever in movie mode. The Fn lever switches to the function set with [ Dial Function] when set to [mode1]. To choose the function selected using the Fn lever, highlight [mode2], press  , and choose from AF mode, AF target mode, and AF target selection. This setting has no effect when [mode3] is selected for [ Fn Lever Function] (P. 185) or when [Power 1] or [Power 2] is selected for [Fn Lever/Power Lever] (P. 185).	—
 Shutter Function	Choose the role played by shutter button in movie mode. When set to [], pressing the shutter button initiates autofocus. Still image photography is not available. When set to [ REC], movie recording can be started or stopped by pressing the shutter button all the way down. The  button cannot be used for starting or stopping movie recording with this setting.	—
 Elec. Zoom Speed	Choose the zoom speed for power zoom lenses. This can be used for slow zooms on your subject and other effects. Choose from [Low], [Normal], and [High].	—

Option	Description	
 Display Settings	Adjust display settings for movie mode.	—
 Control Settings	Choose whether live controls (P. 225) and the live super control panel (P. 88) are displayed in movie mode. For setting not to display, select the item and press the  button to clear the check mark.	—
 Info Settings	Choose the information displayed during recording in movie mode. For setting not to display, select the item and press the  button to clear the check mark.	—
Time Code Settings	Choose how time codes are recorded in movie mode. Set [Time Code Mode] to [Drop Frame] to record time codes corrected for errors with respect to recording time, and to [Non-DF] (no drop frame) to record uncorrected time codes. Set [Count Up] to [Rec Run] to run time codes during recording only, and to [Free Run] to run time codes even while recording is stopped, including when the camera is turned off. In [Starting Time], set a starting time for the time code. Set [Current Time] to set the time code for the current frame to 00. To set to 00:00:00:00, select [Reset]. You can also set time codes using [Manual Input].	—
 Display Pattern	Choose whether the battery level is displayed as a percentage (“%”) or as minutes remaining (“min”) in movie mode and during movie recording.	—
 View Assist	The display can be adjusted for ease of viewing when a movie-only picture mode option ([ Flat] or [ OM-Log400]) is selected. Select [On] to adjust the display hues for ease of viewing.	—
Movie 	Audio will not be recorded in a movie when set to [Off].	169
 HDMI Output	Adjust output settings for movies recorded with the camera connected with an external device via HDMI.	—
Output Mode	Choose the video output mode. When set to [Monitor Mode], image and camera information are output. The camera information is not displayed on the camera screen. When set to [Record Mode], only image is output. The camera information is displayed on the camera screen.	—
REC Bit	If set to [On], the REC trigger is sent from the camera to the connected external device.	—
Time Code	If set to [On], the time code is sent from the camera to the connected external device. <ul style="list-style-type: none"> • The recording by the external device that uses the time code as the REC trigger may be stopped in the following cases. <ul style="list-style-type: none"> - When recording an ART movie, etc., under heavy processing load - When switching the display between the monitor and viewfinder 	—

Choosing an Exposure Mode (Mode (Movie Exposure Modes))

You can create movies that take advantage of the effects available in **P**, **A**, **S**, and **M** modes. This option takes effect when the mode dial is rotated to .

- 1 Select [ Mode Settings] in  Video Menu and press the  button.
- 2 Select [ Mode] (movie exposure modes) and press .
- 3 Use   to select an option and press the  button.

P	Optimal aperture is set automatically according to the brightness of the subject. Use the front dial or rear dial to adjust exposure compensation.
A	Depiction of background is changed by setting the aperture. Use the front dial to adjust exposure compensation and rear dial to adjust aperture.
S	Shutter speed affects how the subject appears. Use the front dial to adjust exposure compensation and rear dial to adjust shutter speed. Shutter speed can be set to values between 1/24 s and 1/32000 s.
M	<p>Freely adjust both aperture and shutter speed. Use the front dial to select aperture value and the rear dial to select shutter speed.</p> <ul style="list-style-type: none"> • Choose from shutter speeds of 1/24–1/32000 s. Values of ISO 200–6400 are available using the [ ISO] manual sensitivity control options. • The display shows the difference between the exposure produced by the selected aperture and shutter speed and the optimal exposure metered by the camera. The display will flash if the difference exceeds ± 3 EV. • The option chosen for [ Specification Settings] > [ ISO-Auto Set] (P. 161) takes effect.

- Blurred frames caused by such factors as the subject moving while the shutter is open can be reduced by selecting the fastest available shutter speed.
- The low end of the shutter speed changes according to the frame rate of the movie record mode.
- Excessive camera shake may not be compensated enough.
- When the inside of the camera becomes hot, shooting is automatically stopped to protect the camera.

Reducing Flicker Under LED Lighting (Flicker Scan)

Banding may occur in movies filmed under LED lighting. Use [Flicker Scan] to optimize shutter speed while viewing banding in the display.

This option is in [Mode] (movie exposure modes) [S] and [M].

- The range of available shutter speeds is reduced.

- 1 Select [S] or [M] for [Mode] (movie exposure modes; P. 165).
- 2 Highlight [Mode Settings] in the video menu and press the [OK] button.
- 3 Highlight [Flicker Scan] and press \blacktriangleright .
- 4 Highlight [On] using the Δ ∇ buttons and press the [OK] button.
- 5 Press the **MENU** button repeatedly to exit the menu.
 - A **Flicker Scan** icon is displayed when flicker scan is enabled.



Flicker Scan icon

- 6 Choose a shutter speed while viewing the display.
 - Choose a shutter speed using the front or rear dial or the Δ ∇ buttons. If desired, the shutter speed can be selected by keeping Δ ∇ pressed.
 - You can also rotate the front dial to adjust shutter speed in the exposure increments selected for [EV Step] in **Custom Menu** [E].
 - Continue adjusting shutter speed until banding is no longer visible in the display.
 - Press the **INFO** button; the display will change and the **Flicker Scan** icon will no longer be displayed. You can adjust aperture and exposure compensation. Do so using the front or rear dial or the arrow pad.
 - Press the **INFO** button repeatedly to return to the flicker scan display.
- 7 Begin filming when settings are complete.
 - Focus peaking, the LV super control panel, and live controls are not available in the flicker scan display. To view these items, first press the **INFO** button to exit the flicker scan display.



Shutter speed



- [Flicker Scan] can be assigned to a button. You then need only press the button to enable flicker scan. \mathbb{I} "Assigning functions to buttons (Button Function)" (P. 116)

Frame Size, Rate, and Compression







You can set combinations of movie image size and bit rate. The settings can be selected from options of movie record mode (P. 101).



- 1 Select [⏏ Specification Settings] in [⏏ Video Menu] and press the [OK] button.
- 2 Select [⏏ ←] and press [▶].
- 3 Use [▲ ▼] to select the item and press [▶].
 - Use [▲ ▼] to select the setting and press the [OK] button.













Image size	Sets the image size to [C4K] (Custom only), [4K], [FHD] (Full HD), or [HD].
Bit rate	Sets the bit rate to [A-I] (All-Intra), [SF] (Super Fine), [F] (Fine), or [N] (Normal). <ul style="list-style-type: none">• When [4K] or [C4K] is set for the image size, you cannot select the bit rate.
Frame rate	Sets the frame rate to [60p], [50p], [30p], [25p], or [24p]. <ul style="list-style-type: none">• [60p] and [50p] are not available in the following situations.<ul style="list-style-type: none">- When [FHD] (Full HD) is set for the image size and [A-I] (All Intra) is set for the bit rate.- When [C4K] or [4K] is set for the image size.• If the image size is set to [C4K], the frame rate is locked to 24p.• When shooting movies that will be viewed on a television, choose a frame rate that matches the video standard used in the device, as otherwise the movie may not play back smoothly. Video standards vary by country or region: some use NTSC, others PAL.<ul style="list-style-type: none">- When shooting for display on NTSC devices, choose 60p (30p)- When shooting for display on PAL devices, choose 50p (25p)
Slow or Fast Motion	Sets slow or fast motion. Available settings differ depending on the set frame rate. <ul style="list-style-type: none">• Slow and fast motions cannot be used in some image quality modes.

Assigning Roles to the Front and Rear Dials (Dial Function)











Choose the roles played by the front and rear dials in  (movie) mode. You can reverse the roles of the dials or reassign them for ease of use or as required by shooting conditions. If [mode1] is selected for  Fn Lever Function], the roles played by the dials will vary with the position of the **Fn** lever. Different assignments can be made for each  Mode] (movie exposure mode).





The roles assigned to the dials using this item take effect in  (movie) mode. In **P**, **A**, **S**, **M**, and **B** (still photography) modes, the dials perform the roles selected in the  custom menu.





Role	Function	Exposure mode			
		P	A	S	M
Shutter	Choose the shutter speed.	—	—	✓	✓
FNo.	Adjust aperture.	—	✓	—	✓
	Adjust exposure compensation.	✓	✓	✓	✓
ISO	Adjust ISO sensitivity.	—	—	—	✓
WB	Adjust white balance.	✓	✓	✓	✓
CWB Kelvin	Choose a color temperature when CWB (custom) is selected for white balance.	✓	✓	✓	✓
 VOL	Adjust the recording level.	✓	✓	✓	✓
 VOL	Adjust headphone volume.	✓	✓	✓	✓
Off	None.	✓	✓	✓	✓

- 1 Highlight  Button/Dial/Lever] in the  video menu and press  on the arrow pad.
- 2 Highlight  Dial Function] using the   buttons and press the  button.
- 3 Highlight the desired mode and press the  button.
 - Choose a dial using the   buttons and use the   buttons to choose a role.
 - Press the **INFO** button to move between lever positions.
 - Press the  button when settings are complete.

Adjust settings for recording sound during filming. You can also access settings for use when an external microphone or recorder is connected.

- 1 Select [Movie ) in  Video Menu and press the  button.
- 2 Select [On] and press .
- 3 Use   to select the item and press .
 - Use   to select the setting and press the  button.

Recording Volume	Adjust microphone sensitivity. Choose separate values for the built-in stereo microphone and external microphones. [Built-In ]: Adjust the sensitivity of the camera's built-in stereo microphone. [MIC ]: Adjust the sensitivity of external microphones connected to the microphone jack.
 Volume Limiter	Choose the maximum volume at which the camera will record sound. Use this option to automatically reduce the level of sounds above a certain volume.
Wind Noise Reduction	Reduce wind noise during audio recording.
Recording Rate	Choose an audio recording format. [96kHz/24bit]: High-quality audio. [48kHz/16bit]: Standard-quality audio.
 Plug-in Power	Adjust settings for use with condenser microphones and other devices that draw power from the camera. [Off]: For devices that do not require power from the camera (general-purpose dynamic microphones). [On]: For devices that require power from the camera (condenser microphones).
Headphone Volume	Adjust the volume of audio output to the headphones.

- Operation sounds of the lens and camera may be recorded in a movie. To prevent it from recording, reduce the operation sounds by setting  [AF Mode] (P. 64) to [S-AF], [MF], or [PreMF], or by minimizing the button operations of the camera.
- Sound is not recorded:
 - with high-speed or slow- or fast-motion movies or when  (diorama) is selected for picture mode.
- When [Movie ) is set to [Off],  is displayed.
- Audio can only be played on devices that support the option selected for [Recording Rate].

Using the Playback Menu

Playback Menu

- 🖼️ (P. 170)
- Edit (P. 170)
- Print Order (P. 134)
- Reset Protect (P. 175)
- Reset share Order (P. 175)
- Copy All (P. 175)
- 📶 Wi-Fi Connect (P. 247)

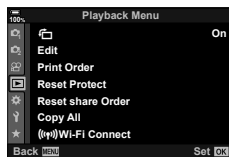

Automatically Rotating Portrait-Orientation Pictures for Playback



If set to [On], images in portrait orientation are automatically rotated to be displayed in the correct orientation on the playback display.

Retouching Pictures



(Edit)

Create retouched copies of pictures. In the case of RAW pictures, you can adjust the settings in effect at the time the picture was taken, such as white balance and picture mode (art filters included). With JPEG pictures, you can make simple edits such as cropping and resizing.

The images to be edited can be chosen from those on the card currently selected for playback. 📷 “Setting the card to record to (Card Slot Settings)” (P. 237)

- 1 Select [Edit] in the 📺 Playback Menu and press the Ⓞ button.
- 2 Use Δ ∇ to select [Sel. Image] and press the Ⓞ button.
- 3 Use \triangleleft \triangleright to select the image to be edited and press the Ⓞ button.
 - [RAW Data Edit] is displayed if a RAW image is selected, and [JPEG Edit] if a JPEG image is selected. For images recorded in RAW+JPEG format, both [RAW Data Edit] and [JPEG Edit] are displayed. Select the desired option from them.
- 4 Select [RAW Data Edit] or [JPEG Edit] and press the Ⓞ button.

RAW Data Edit	Creates a JPEG copy of a RAW image according to the selected settings.	
	Current	Retouch pictures and save the resulting copies in JPEG format. Adjust the camera settings before choosing this option. Some settings such as exposure compensation are not applied.
	Custom1	Press \odot and adjust settings while previewing the results in the display. The settings are saved as [Custom1] or [Custom2].
	Custom2	
ART BKT	The camera creates multiple JPEG copies of each image, one for each art filter selected. Select one or more filters and apply them to one or more images.	

JPEG Edit	The [JPEG Edit] menu contains the following options.	
	Shadow Adj.	Brighten back-lit subjects.
	Redeye Fix	Reduce "red-eye" in pictures taken with a flash.
		Crop pictures. Size the crop with the front or rear dial and position it with the arrow pad.
	Aspect	Change the aspect ratio from the standard 4:3 to [3:2], [16:9], [1:1], or [3:4]. After choosing an aspect ratio, use the arrow pad to position the crop.
	Black & White	Create a black-and-white copy of the current picture.
	Sepia	Create a sepia copy of the current picture.
	Saturation	Adjust the vividness of colors. The results can be previewed in the display.
		Create a resized copy 1280 × 960, 640 × 480, or 320 × 240 pixels in size. Pictures with an aspect ratio other than the standard 4:3 are resized to dimensions as close as possible to the selected option.
	e-Portrait	Smooth complexions. The desired effect may not be achieved if no faces are detected.

- Red-eye reduction may not produce the desired results with some pictures.
- Retouch is not available:
 - with pictures that were taken with another camera or edited on a computer or if the space available on the memory card is insufficient.



5 Press the **OK** button when settings are complete.

- The selected settings will be applied.

6 Press the **OK** button again.

- Highlight [Yes] using the **Δ** **∇** buttons and press the **OK** button to save the retouched copy.



- To create additional copies from the same original RAW image, highlight [Reset] and press the **OK** button. To exit without creating more copies, highlight [No] and press the **OK** button.
- Selecting [Reset] displays the retouch menu. Repeat the process from Step 4.
- You can also edit selected pictures during playback.
 -  button → Display a picture you want to retouch → Press the **OK** button to view options → [RAW Data Edit] or [JPEG Edit]
- Red-eye correction may not work depending on the image.
- The image cannot be resized () to the larger size than the original size.
- [] (trimming) and [Aspect] can only be used to edit images with an aspect ratio of 4:3 (standard).
- When [ART] is selected for picture mode, [Color Space] (P. 114) will be locked at [sRGB].









Combining Pictures

(Image Overlay)

Overlay existing RAW photos and to create a new picture. Up to 3 pictures can be included in the overlay.

The results can be modified by adjusting brightness (gain) separately for each picture.

- The overlay is saved in the format currently selected for image quality. Overlays created with [RAW] selected for image quality are saved in RAW format and in JPEG format using the image quality option selected for [Q:2] (P. 194).
- Overlays saved in RAW format can in turn be combined with other RAW images to create overlays containing 4 or more pictures.



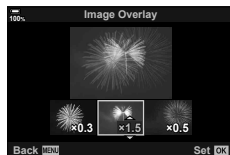
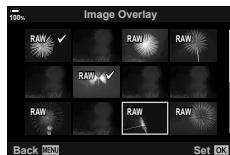









- 1 Select [Edit] in the  Playback Menu and press the  button.
- 2 Use Δ ∇ to select [Image Overlay] and press the  button.
- 3 Select the number of images to be overlaid and press the  button.
- 4 Use Δ ∇ \triangleleft \triangleright to select the RAW images to be overlaid.
 - Selected pictures are marked with a . To deselect, press the  button again.
 - The overlaid image will be displayed if images of the number specified in step 3 are selected.
- 5 Adjust the gain for each image to be overlaid.
 - Use \triangleleft \triangleright to select an image and Δ ∇ to adjust gain.
 - Gain can be adjusted in the range 0.1–2.0. Check the results in the monitor.
- 6 Press the  button to display the confirmation dialog.
 - Select [Yes] and press the  button.



Creating Movie Stills (In-Movie Image Capture)













Save a still copy of a selected frame.

- This option is available only with [4K] movies recorded with the camera.

- 1** Select [Edit] in the  Playback Menu and press the  button.
- 2** Use  to select [Sel. Image] and press the  button.
- 3** Use  to select a movie and press the  button.
- 4** Select [Movie Edit] and press the  button.
- 5** Use  to select [In-Movie Image Capture] and press the  button.
- 6** Use  to select a frame to be saved as a still image and press the  button.
 - The camera will save a still copy of the selected frame.
 - Use the  button to go back 2 seconds and the  button to skip ahead 2 seconds.





Cut selected footage from movies. Movies can be trimmed repeatedly to create files containing only footage you want to preserve.

- This option is available only with movies recorded with the camera.

- 1** Select [Edit] in the  Playback Menu and press the  button.
- 2** Use Δ ∇ to select [Sel. Image] and press the  button.
- 3** Use \triangleleft \triangleright to select a movie and press the  button.
- 4** Select [Movie Edit] and press the  button.
- 5** Use Δ ∇ to select [Movie Trimming] and press the  button.
 - You will be prompted to choose how you want to save the edited movie.
[New File]: Save the trimmed movie in a new file.
[Overwrite]: Overwrite the existing movie.
[No]: Exit without trimming the movie.
 - If the image is protected, you cannot select [Overwrite].
- 6** Highlight the desired option and press the  button.
 - You will be presented with an edit display.
- 7** Trim the movie.
 - Use the Δ button to skip to the first frame and the ∇ button to skip to the last frame.
 - Using the front or rear dial, highlight the first frame of the footage you want to delete and press the  button.
 - Using the front or rear dial, highlight the last frame of the footage you want to delete and press the  button.
- 8** Highlight [Yes] and press the  button.
 - The edited movie will be saved.
 - To select different footage, highlight [No] and press the  button.
 - If you selected [Overwrite], you will be prompted to choose whether to trim additional footage from the movie. To trim additional footage, highlight [Continue] and press the  button.





Removing Protection from All Pictures (Reset Protect)

Protections of multiple images can be canceled at a time.

- 1 Select [Reset Protect] in the  Playback Menu and press the  button.
 - When there are cards in both slots 1 and 2, card slot selection appears. Select a card slot and press the  button.
- 2 Select [Yes] and press the  button.



Cancelling a share order (Reset share Order)



Cancel share orders that are set on images.

- 1 Select [Reset share Order] in the  Playback Menu and press the  button.
 - When there are cards in both slots 1 and 2, card slot selection appears. Select a card slot and press the  button.
- 2 Select [Yes] and press the  button.

Copying All Pictures (Copy All)

All images can be copied between the cards inserted in the camera (card slot 1 and 2).

- 1 Select [Copy All] in the  Playback Menu and press the  button.
- 2 Select an option and press the  button.

	All images are copied from the card in card slot 1 to the card in card slot 2.
	All images are copied from the card in card slot 2 to the card in card slot 1.

- 3 Select [Yes] and press the  button.
 - Copying ends when the destination card is full.

Using the setup menu

Adjust basic camera settings. Examples include language selection and monitor brightness. The setup menu also contains options used during the initial setup process.

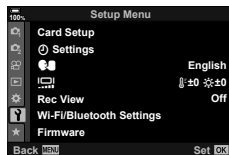

Option	Description	
Card Setup	Format the card and delete all images.	177
Settings (Date/time setting)	Set the camera clock.	33
Language (Changing the display language)	Choose a language for camera menus and guides.	35
Monitor (Monitor brightness adjustment)	<p>You can adjust the brightness and color temperature of the monitor. Color temperature adjustment is only applied to the monitor display during playback. Use $\leftarrow \rightarrow$ to highlight $\text{[Color Temperature]}$ or [Brightness] (color temperature) or [Brightness] (brightness) and $\uparrow \downarrow$ to adjust the value.</p> <p>Press the INFO button to switch the saturation of the monitor between [Natural] and [Vivid] settings.</p>	—
Rec View	<p>Choose whether pictures are automatically displayed in the monitor after they are taken and if so, for how long. This is useful for a brief check of the picture you have taken. You can shoot the next shot by pressing the shutter button halfway even while the captured image is displayed on the monitor.</p> <p>[0.3sec]–[20sec]: Choose how long (in seconds) pictures are displayed in the monitor after shooting.</p> <p>[Off]: The captured image is not displayed on the monitor.</p> <p>[Auto] [▶]: After shooting, the camera displays the latest picture and then enters playback mode. This is useful for erasing a picture after checking it.</p>	—
Wi-Fi/Bluetooth Settings	Adjust settings for connection to Wi-Fi/ Bluetooth [®] -compatible smartphones using the camera's wireless function.	178
Firmware	View the firmware versions of the camera and connected accessories. Check the versions when you inquire about the camera or accessories or when you download the software.	—



Formatting the card



(Card Setup)

Cards must be formatted with this camera before first use or after being used with other cameras or computers.

All data stored on the card, including protected images, is erased when the card is formatted.

When formatting a used card, confirm there are no images that you still want to keep on the card.  “Usable cards” (P. 284)

1 Select [Card Setup] in the  Setup Menu and press the  button.

- When there are cards in both slots 1 and 2, card slot selection appears. Select a card slot and press the  button.
- If there is data on the card, menu items appear. Select [Format] and press the  button.

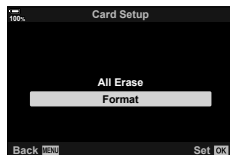



2 Select [Yes] and press the  button.

- Formatting is performed.

Deleting all images

(Card Setup)

All images on a card can be deleted at a time. Protected images are not deleted.

1 Select [Card Setup] in the  Setup Menu and press the  button.

- When there are cards in both slots 1 and 2, card slot selection appears. Select a card slot and press the  button.

2 Select [All Erase] and press the  button.

3 Select [Yes] and press the  button.

- All images are deleted.

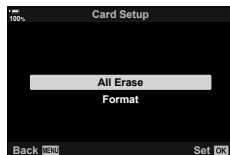

Adjust settings for connection to wireless networks. Take pictures and view pictures using a computer, or leave the camera off and view pictures on your smartphone while on the road. For information on establishing a connection and using these features, see “Connecting to Smartphones via Wi-Fi” (P. 245) and “Connecting to Computers via Wi-Fi” (P. 256).

Availability	Disable Wi-Fi and Bluetooth [®] . Disable Wi-Fi and Bluetooth [®] , for example in settings in which their use is prohibited, without changing network settings (P. 255).
Connection Password	Change the Wi-Fi/ Bluetooth [®] password.
Power-off Standby	Choose whether the camera will connect to smartphones while off.
RAW+JPEG 	In the case of pictures recorded with [RAW+JPEG] for image quality, you can choose to share only the JPEG copies, only the RAW copies, or both the JPEG and RAW copies (P. 133).
Reset Settings	Restore defaults for [Wi-Fi/Bluetooth Settings].
Wi-Fi MAC Address	Display the camera MAC address, which is sometimes needed when adjusting wireless network settings.

Using “My Menu”

You can use “My Menu” to create a personalized menu tab containing only items you select. “My Menu” can contain up to 5 pages of 7 items each. You can delete items or change the page or item order.

At purchase, “My Menu” contains no items.

- 1 Press the **MENU** button to display the menus.
- 2 Highlight an item for inclusion in “My Menu”.
 - Items that can be added to “My Menu” are indicated by a ★ icon at the top right corner of the display.

Item can be added to
“My Menu”

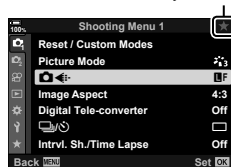

- 3 Press the **MOVIE** button.

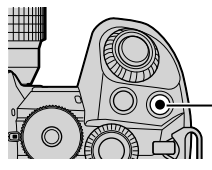

MOVIE (movie) button

- You will be prompted to choose a page. Use **UP**/**DOWN** on the arrow pad to choose the “My Menu” page to which the item will be added.

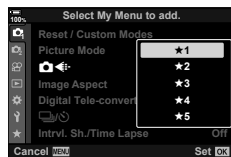

4 Press the **OK** button to add the item to the selected page.

- The camera will display a message stating that the item has been added to "My Menu".

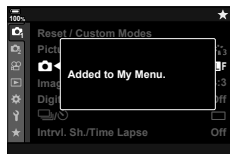

- Items that have been added to "My Menu" are indicated by a yellow **★**.
- The next available page will be displayed once the seventh item is added to the current page.
- Items marked with a **★** can be removed from "My Menu" by pressing the **OK** button. A confirmation dialog will be displayed; to proceed, highlight [Yes] and press the **OK** button.
- Items saved to "My Menu" are added to the **★** ("My Menu") tab.

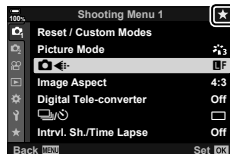

★ ("My Menu") tab

5 To access "My Menu", select the **★** ("My Menu") tab.

■ Managing "My Menu"

You can rearrange items in "My Menu", move them between pages, or remove them from "My Menu" altogether.

1 Press the **MENU** button to display the menus.

2 Display the "My Menu" page you want to edit and press the **OK** (movie) button.

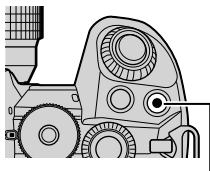

OK (movie) button

- The options below will be displayed.

[Rearrange Order]: Change the order of items or pages. Use the arrow pad (**△ ▽ <|>**) to choose the new location.

[Remove this item]: Remove the highlighted item from "My Menu". Highlight [Yes] and press the **OK** button.



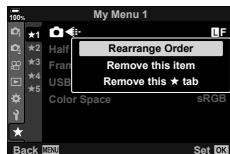



[Remove this **★** tab]: Remove from "My Menu" all items on the current page. Highlight [Yes] and press the **OK** button.



Using the custom menus

Camera settings can be customized using the  Custom Menu.





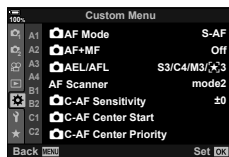

Custom Menu



A1/A2/A3/A4	AF/MF (P. 181)
B1/B2	Button/Dial/Lever (P. 185)
C1/C2	Release/  Image Stabilizer (P. 186)
D1/D2/D3/D4	Disp/  PC (P. 187)
E1/E2/E3	Exp/ISO/BULB/  (P. 191)
F	 Custom (P. 193)
G	 WB/Color (P. 194)
H1/H2	Record/Erase (P. 195)
I	EVF (P. 196)
J1/J2	 Utility (P. 198)









A1 AF/MF

MENU →  → **A1**











Option	Description	
 AF Mode	Choose the AF mode for still image shooting.	64, 91
 AF+MF	You can rotate the lens focus ring to adjust focus manually after focusing with autofocus.	200
 AEL/AFL	Choose how the camera sets focus and exposure when the shutter button or AEL/AFL button is pressed.	201
AF Scanner	<p>Choose the type of AF scan* performed in autofocus mode when the camera is unable to focus or the scene lacks contrast.</p> <p>* Scans whole range from minimum range to infinity for focus point when the camera cannot focus on the subject or the contrast is not clear.</p> <ul style="list-style-type: none"> The selected option takes effect when [C-AF], [C-AF+TR], [C-AF MF], or [C-AF+TR MF] is chosen for [ AF Mode] (P. 64). This item is for still photography. <p>[mode1]: AF Scanner is not activated. [mode2]: An AF scan is performed only once at the start of the focus operation. [mode3]: AF Scanner is activated.</p>	—
 C-AF Sensitivity	Choose how rapidly the camera responds to changes in the distance to the subject while focusing with [C-AF], [C-AF MF], [C-AF+TR], or [C-AF+TR MF] selected for [ AF Mode]. This can help autofocus track a quickly-moving subject or prevent the camera refocusing when an object passes between the subject and the camera.	203

Option	Description	
 C-AF Center Start	When used in combination with an AF-target mode other than single target, [C-AF], [C-AF MF], [C-AF+TR], and [C-AF+TR MF] focus on the center of the selected group only during the initial scan. During later scans, the camera will focus using the surrounding targets. Combining this option with an AF-target mode that covers a wide area makes it easier to focus on erratically-moving subjects.	204
 C-AF Center Priority	When focusing using group- or custom-target AF in [C-AF] and [C-AF MF] modes, the camera always assigns priority to the center target in the selected group for a repeated series of focus operations. Only if the camera is unable to focus using the center focus target will it focus using the surrounding targets in the selected focus group. This helps you track subjects that are moving quickly but relatively predictably. C-AF center priority is recommended in most situations.	205



A2 AF/MF**MENU** →  →  **A2**

Option	Description	
 [:::]Mode Settings	Choose the target modes displayed during AF-target mode selection. Hiding unused modes speeds target-mode selection. To hide an item, highlight it and press the  button to remove the check (✓).	69, 71
AF Area Pointer	In autofocus mode, the position of the subject on which the camera has focused is shown by a green focus target. This item controls the display of the focus target. [Off]: The focus target is not displayed. [On1]: The focus target is displayed only briefly after the camera focuses. [On2]: After the camera focuses, the focus target will be displayed while the shutter button is pressed halfway. • To enable cluster AF targeting when  (all targets) is selected and [S-AF], [S-AF MF], [C-AF], or [C-AF MF] is chosen for  AF Mode] (P. 64) or [C-AF] is selected for  AF Mode], select [On2] for [AF Area Pointer]. The camera will display AF targets for all areas that are in focus.	—
[:::] Set Home	Choose the home position AF mode, AF target selection mode, and AF target mode. Press the  button to select the desired options in the [:::] Set Home] display.	206























Option	Description	
 Select Screen Settings	Choose the roles played by the front and rear dials or arrow pad during AF target selection.	207
 Loop Settings	Choose whether AF-target selection “wraps around” the edges of the display. You can also choose whether you have the option of selecting  (all targets) before AF-target selection “wraps around” to the opposite border of the display. • Wrap is disabled in movie mode and when  AF or  AF MF is selected for  AF Mode].	208
 Target Mode Settings	Choose the number of AF targets available and how far the AF target moves during AF-target selection.	209
 Orientation Linked 	The camera can be configured to change the AF-target position and AF-target mode automatically when it detects that it has been rotated between landscape (wide) or portrait (tall) orientations.	210

 AF/MF**MENU** →  →  ****

Option	Description	
AF Targeting Pad	If [On] is selected, the AF target can be positioned by tapping the monitor during viewfinder photography. Tap the monitor and slide your finger to position the AF target. • When set to [On], drag operation can be disabled or enabled by double-tapping the monitor. • [AF Targeting Pad] can also be used with zoom frame AF (P. 73).	—
AF Limiter	Limits the AF area when turned [On].	211
AF Illuminator	Select [Off] to disable the AF illuminator. To use the AF illuminator during silent photography, you will need to change the option selected for [Silent  Mode Settings] (P. 157).	—
 Face Priority	You can select the face priority or eye priority AF mode.	92
AF Focus Adj.	Focal location adjustment for phase-difference AF can be fine tuned within a range of ± 20 steps. • Normally there is no need to fine-tune autofocus using this item. Fine-tuning focus may prevent the camera focusing normally.	212







Option	Description	
Starry Sky AF Setting	[Accuracy]: Prioritize focus accuracy over speed. Use a tripod. [Speed]: Prioritize focus speed over accuracy.	64
Preset MF distance	Choose the Preset MF focus position. Numerical value and unit (m, ft) can be set. The distance is approximate and not exact.	—
MF Assist	You can automatically switch to zoom or peaking in manual focus mode by rotating the focus ring.	215
MF Clutch	Disable the manual focus clutch. This can prevent autofocus being disabled by the clutch engaging accidentally. [Operative]: The camera responds to the position of the lens focus ring. [Inoperative]: The camera focuses according to the option selected for [AF Mode], regardless of the position of the lens focus ring. Manual focus is not available even when the focus ring is in the manual focus position.	286
Focus Ring	You can customize how the lens adjusts to the focal point by selecting the rotational direction of the focus ring.	—
Bulb/Time Focusing	You can change the focus position during exposure by using manual focus (MF). When set to [Off], rotation of the focus ring is disabled.	216
Reset Lens	When set to [Off], the focus position of the lens is not reset even when the power is turned off. When set to [On], the focus of power zoom lenses is also reset. • Regardless of the option selected, the focus position will be reset when the camera is turned off if [PreMF] (P. 64) is selected for [AF Mode].	—

Option	Description	
 Button Function	Other roles can be assigned to buttons in place of their existing functions.	116
 Center Button	Choose the operation performed by pressing the multi selector.	217
 Direction Key	Choose the operation performed by tilting the multi selector.	217
 Dial Function	You can change the function of the front dial and rear dial.	218
Dial Direction	Choose the direction in which the dial is rotated to adjust shutter speed or aperture. Change the program shift direction in which the dial is rotated.	—
 Fn Lever Function	Choose the function performed by the Fn lever.	219
Fn Lever/Power Lever	Use the Fn lever as a power switch. [Fn]: Follows settings for the Fn lever function. [Power 1]: The power turns on when the Fn lever is in position 1, and off when in position 2. [Power 2]: The power turns on when the Fn lever is in position 2, and off when in position 1. When [Power 1] or [Power 2] is set, the ON/OFF lever (power lever),  Fn Lever Function] and  Fn Lever Function] are disabled.	—

Option	Description	
 Elec. Zoom Speed	Choose the speed at which power zoom lenses zoom in or out when the zoom ring is rotated. Adjust zoom speed if it is so quick that you find it hard to frame your subject. Choose from [Low], [Normal], and [High].	—
  Function	Choose the role played by the  button during playback. [<]: Create or modify a "share order" by marking pictures for upload to a smartphone. [✓]: Select multiple pictures.	—
 Lock	If [On] is selected,    and  button operations for PBH (Power Battery Holder) are disabled.	—
 Lock	Select [On] to disable the  button.	16





1 Release//Image Stabilizer











MENU → * → 1



Option	Description	
S-AF Release Priority	If [On] is selected, the shutter can be released even when the camera is not in focus. This option can be set separately for S-AF and C-AF modes (P. 64).	—
C-AF Release Priority	<ul style="list-style-type: none"> Regardless of the option selected, [S-AF Release Priority] is used when [AF] is selected for AF mode. This item is for still photography. 	—
 L Settings	Choose frame advance rates and shot limits for [], [], and [] modes. You can also adjust Pro Capture settings, including the frame advance rate, number of frames buffered, and the shot limit. Figures for sequential shooting speed are the approximate maximums. <ul style="list-style-type: none"> This item is for still photography. 	220
 H Settings		
Flicker Reduction	Reduce flicker in photos taken under fluorescent or other artificial lighting. <ul style="list-style-type: none"> This item is for still photography. <hr/> [Anti-Flicker LV]: Reduce flicker during live view under some kinds of lighting, including fluorescent lamps. If [Auto] does not have the desired effect, select [50 Hz] or [60 Hz] according to the frequency of the local power supply. <hr/> [Anti-Flicker Shooting]: The camera automatically detects the flicker frequency and times the shutter release accordingly.	222

2 Release//Image Stabilizer

MENU → * → 2

Option	Description	
 Image Stabilizer	Adjust image stabilization settings for still photography.	97
 Image Stabilizer	Choose whether the camera prioritizes frame rate or image stabilization during burst photography. <ul style="list-style-type: none">  Image Stabilizer] is fixed at [Fps Priority] in P_{CapL} (Pro Capture Low) and P_{CapH} (Pro Capture High) modes. <hr/> [Fps Priority]: Shooting speed gets priority over image stabilization. The sensor will not be reset to the center during sequential shooting. <hr/> [IS Priority]: Image stabilization gets priority over shooting speed. The sensor will be reset to the center per frame of sequential shooting. The shooting speed will drop slightly.	—
Half Way RIs With IS	When set to [Off], the IS (Image Stabilization) function while the shutter button is pressed halfway will not be activated.	—
Lens I.S. Priority	Select [On] to give priority to lens on-board image stabilization when shooting with third-party lenses. [S-IS 1] will be used when [S-IS AUTO] is selected for [ Image Stabilizer] (P. 97). <ul style="list-style-type: none"> This option has no effect on lenses that are equipped with an image stabilization switch. 	—

Option	Description	
 Control Settings	Use this option to hide live controls (P. 225) or the LV super control panel (P. 90) for each shooting mode so that they cannot be displayed via the INFO button. To hide an item, highlight it and press the  button to remove the check mark.	224
 /Info Settings	Choose the information displayed when the INFO button is pressed. [] Info : Choose the information displayed in full frame playback. [] Info : Choose the information displayed in magnified playback. [LV-Info]: Choose the information displayed when the camera is in shooting mode. [LV OFF-Info]: Choose a shooting display. [] Settings : Choose the information displayed in index and calendar playback.	226, 228
Picture Mode Settings	Choose the picture modes (P. 106) available for selection. To hide an item, highlight it and press the  button to remove the check mark.	—
 Settings	Choose the sequential shooting/self-timer modes (P. 78) available for selection. To hide an item, highlight it and press the  button to remove the check mark.	—
Multi Function Settings	Choose the multi function options (P. 124) available for selection. To hide an item, highlight it and press the  button to remove the check mark.	—

Option	Description	
Live View Boost	<p>Adjust brightness for ease of viewing when lighting is poor. Settings can be adjusted separately for mode M, bulb photography, live composite photography, and the like.</p> <p>[Off]: Preview exposure in live view. Exposure can be previewed before shooting.</p> <ul style="list-style-type: none"> This option does not apply during bulb or time photography. <p>[On1]: Exposure preview disabled; brightness is adjusted for ease of viewing. The brightness of the preview differs from the final photograph.</p> <p>[On2]: As for [On1] but brighter. Choose when framing shots of the night sky or the like.</p> <ul style="list-style-type: none"> The brightness of the preview differs from the final photograph. Subject motion may also appear slightly jerky. Press ▷ on the arrow pad and choose from the following: <ul style="list-style-type: none"> [Quality Priority]: Prioritize display quality. [Frame Rate Priority]: Prioritize display speed. 	—
Art LV Mode	<p>[mode1]: The filter effect is always displayed.</p> <p>[mode2]: Priority is given to smooth display while the shutter button is pressed halfway. The quality of art filter effect previews may be affected.</p>	—
Frame Rate	<p>[Normal]: The normal display rate. Select this option in most circumstances.</p> <p>[High]: Smooths motion even when the subject is moving quickly. Fast-moving subjects are easier to track. [Normal] will be selected automatically if the camera's internal temperature rises during shooting.</p>	—
LV Close Up Settings	<p>[LV Close Up Mode]: When set to [mode1], pressing the button halfway in the magnified live view returns to the magnified frame display. When set to [mode2], pressing the button halfway in the magnified live view switches to the Zoom AF display.</p> <p>[Live View Boost]: If [On] is selected, the camera will adjust display brightness for ease of viewing during focus zoom. When set to [Off], the magnified area is displayed with the brightness of live view before magnification. This is useful to check the focus when shooting in backlit locations.</p> <ul style="list-style-type: none"> This item is available when [Off] is selected for [Live View Boost] in ⚙ Custom Menu D2. 	—
  Default Setting	Choose the starting zoom ratio for playback zoom (close-up playback).	229









Option	Description	
Settings	<p> Lock: Select [On] to maintain the aperture at the selected value even when releasing the button.</p> <p>[Live View Boost]: If [On] is selected, the camera will adjust display brightness for ease of viewing during depth-of-field preview (P. 117).</p> <ul style="list-style-type: none"> This item is available when [Off] is selected for [Live View Boost] in Custom Menu D2. 	—

D3 Disp//PC

MENU → → **D3**



Option	Description	
Grid Settings	<p>Adjust settings for the framing grid.</p> <p>[Display Color]: Adjust guide color and transparency. The camera can store up to two combinations of settings.</p> <p>[Displayed Grid]: Select the type of guides displayed. Choose from: , , , , , and </p> <ul style="list-style-type: none"> When is selected, the guides are adjusted for a 16:9 movie frame when movies are shot in still photography mode. Depending on the option selected for : 17:9, the guides may be displayed with an aspect ratio of 17:9. <p>[Apply Settings to EVF]: Choose whether the option selected for [Displayed Grid] is reflected in the viewfinder display. The option selected for [EVF Grid Settings] in Custom Menu D1 (P. 197) has no effect.</p>	—
Peaking Settings	<p>Highlight objects using color outlines. This makes objects that are in focus easier to see during manual focus and the like.</p> <p>[Peaking Color]: Choose the focus peaking color.</p> <p>[Highlight Intensity]: Choose the focus peaking level.</p> <p>[Image Brightness Adj.]: Adjust background brightness to make focus peaking easier to see.</p> <ul style="list-style-type: none"> When [On] is selected for [Image Brightness Adj.], the live view display may be brighter or darker than the final photograph. 	—
Histogram Settings	<p>[Highlight]: Choose the lower bound for the highlight display.</p> <p>[Shadow]: Choose the upper bound for the shadow display.</p>	226
Mode Guide	Select [On] to display a help for the selected mode when the mode dial is rotated to a new setting.	41
Selfie Assist	If [On] is selected, the camera will display a mirror image of the view through the lens when the monitor is in the selfie position.	229

Option	Description	
■) (Beep sound)	<p>[On]: A beep sounds after successful autofocus operations. The beep sounds only when the camera first focuses using [C-AF].</p> <p>[Off]: A beep does not sound after successful autofocus operations.</p>	—
HDMI	<p>[Output Size]: Selecting the digital video signal format for connecting to a TV via an HDMI cable.</p> <p>[HDMI Control]: Select [On] to allow the camera to be operated using remotes for TVs that support HDMI control. This option takes effect when pictures are displayed on a TV. When [On] is selected, the camera can be used for playback only.</p> <p>[Output Frame Rate]: Select the output frame rate from [50p Priority] or [60p Priority] for using the camera connected to a TV with an HDMI cable.</p>	230
USB Mode	Choose how the camera functions when connected to external devices via USB.	231, 275, 277, 278

Option	Description	☞
EV Step	Choose the size of the increments used when adjusting shutter speed, aperture, exposure compensation, and other exposure-related settings.	—
ISO Step	Choose the size of the increments used when adjusting ISO sensitivity.	—
 ISO-Auto Set	Adjust [AUTO] ISO sensitivity settings for still photography. [Upper Limit/Default]: Choose the maximum and default ISO sensitivity used when [AUTO] is selected for ISO. Select [Upper Limit] to choose the maximum sensitivity, [Default] to choose the default sensitivity. The maximum is 6400. The maximum ISO sensitivity automatically changes: <ul style="list-style-type: none"> • to ISO 800 when the live ND filter is enabled, • to ISO 1600 when [Shooting Method] > [Tripod] is selected for High Res Shot, and • to ISO 1600 when [Dramatic Tone] or [Watercolor] is selected for picture mode. [Lowest S/S Setting]: Choose the shutter speed at which the camera starts raising ISO sensitivity automatically in modes P and A . Choose [Auto] to let the camera choose a shutter speed automatically.	—
 ISO-Auto	Choose the shooting modes in which [AUTO] ISO sensitivity takes effect. [P/A/S]:  ISO > [AUTO] takes effect only in modes P , A , and S . If [AUTO] is in effect when mode M or B is selected,  ISO will be set to ISO 200. [All]:  ISO > [AUTO] takes effect only in modes P , A , S , and M . If you select mode B after choosing [AUTO],  ISO will be set to ISO 200.	—
 Noise Filter	Choose the amount of noise reduction performed at high ISO sensitivities.	—
 Low ISO Processing	Choose the type of processing applied to photographs taken at low ISO sensitivities. [Drive Priority]: Image processing is adapted so as not to curtail the number of pictures that can be taken in a single burst. [Detail Priority]: Image processing prioritizes image quality.	—

Option	Description	
Noise Reduct.	<p>This function reduces the noise that is generated during long exposures.</p> <ul style="list-style-type: none"> The time required for noise reduction is shown in the display. [Off] is selected automatically during sequential shooting. This function may not work effectively with some shooting conditions or subjects. <p>[Auto]: Noise reduction is performed at slow shutter speeds, or when the internal temperature of the camera has risen.</p> <p>[On]: Noise reduction is performed with every shot.</p> <p>[Off]: Noise reduction off.</p>	—









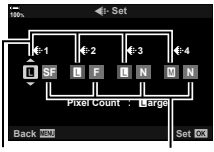

E2 Exp/ISO/BULB/ 
MENU →  → 

Option	Description	
Bulb/Time Timer	Choose the maximum exposure for bulb and time photography.	52
Live Composite Timer	Choose the maximum exposure time for composite photography.	54
Bulb/Time Monitor	Choose the brightness of the monitor when shooting in B (bulb) mode.	—
Live Bulb	Choose the display interval during shooting. The number of update times is limited. Choose [Off] to disable the display.	232
Live Time		232
Composite Settings	Set an exposure time to be the reference in composite photography.	233
 Flicker Scan	Reduce flicker under LED lighting.	234

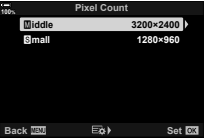
Option	Description	
Metering	Choose a metering mode according to the scene.	77
AEL Metering	Choose the metering method used to meter exposure when exposure is locked using the AEL/AFL button. This allows you to use one metering method when exposure is locked by pressing the shutter button halfway and another when exposure is locked by pressing the AEL/AFL button. <ul style="list-style-type: none"> • This item is for still photography. [Auto]: Exposure is metered using the method selected for [Metering] (P. 77).	—
[⋮] Spot Metering	Choose whether the [Spot], [Spot Highlight], and [Spot Shadow] spot metering options meter the selected AF target. <ul style="list-style-type: none"> • [☺ Face Priority] is automatically set to [Face Priority Off]. • The selected option takes effect when [·] (single target) or [·]s (small target) is selected as the AF-target mode (P. 69). • The camera zooms in on the selected AF target during focus zoom (P. 73). • This item is for still photography. 	—
Exposure Shift	Adjust correct exposure separately for each metering mode.	235

F ⚡ Custom

Option	Description	
⚡ X-Sync.	Choose the fastest shutter speed available when a flash is used.	236
⚡ Slow Limit	Choose the slowest shutter speed available when a flash is used.	236
[+/-] + [⊞]	When set to [On], the exposure compensation value is added to the flash compensation value.	68, 105
⚡ +WB	Adjust white balance for use with a flash. <ul style="list-style-type: none"> [Off]: The camera uses the value currently selected for white balance. [Auto]: The camera uses auto white balance ([Auto]). [WB⚡]: The camera uses flash white balance ([WB⚡]). 	—
⚡ RC Mode	Wireless remote-control flash units can be used with the flash unit for wireless remote-control flash photography.	288



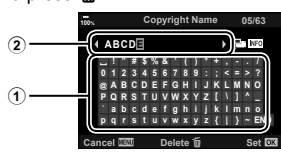











Option	Description	
<p>← Set</p>	<p>You can select the JPEG image quality mode from combinations of three image sizes and three compression rates.</p> <p>1) Use <math>\triangleleft \triangleright</math> to select a combination ([←1] – [←4]) and use <math>\triangle \nabla</math> to change.</p> <p>2) Press the  button.</p> <div data-bbox="319 244 841 463" style="border: 1px solid gray; padding: 5px;">  </div>	<p>100, 142, 236</p>
<p>Pixel Count</p>	<p>Choose the pixel count for [M]- and [S]-size images.</p> <p>1) Select [Middle] or [Small] and press <math>\triangleright</math>.</p> <p>2) Choose a pixel count and press the  button.</p> <div data-bbox="319 521 841 681" style="border: 1px solid gray; padding: 5px;">  </div>	<p>100, 142, 236, 316</p>
<p>Shading Comp.</p>	<p>Choose [On] to correct peripheral illumination according to the type of lens.</p> <ul style="list-style-type: none"> • Compensation is not available for teleconverters or extension tubes. • Noise may be visible at the edges of photographs taken at high ISO sensitivities. 	<p>—</p>
<p> WB</p>	<p>Choose a white balance mode for still photography. You can also fine-tune the white balance for each mode.</p>	<p>94</p>
<p> All </p>	<p>Fine-tune white balance across the board.</p> <ul style="list-style-type: none"> • This item is for still photography. <p>[All Set]: Fine-tune white balance for all modes.</p> <p>[All Reset]: Reset fine-tuning for all modes to default values.</p>	<p>96</p>
<p>  AUTO Keep Warm Color</p>	<p>Select [On] to preserve “warm” colors in pictures taken with [AUTO] white balance under incandescent lighting.</p> <ul style="list-style-type: none"> • This item is for still photography. 	<p>94, 96</p>
<p>Color Space</p>	<p>You can select a format to ensure that colors are correctly reproduced when shot images are regenerated on a monitor or using a printer.</p>	<p>114</p>

Option	Description	
Card Slot Settings	Choose the card used to record photographs or movies.	237
File Name	<p>[Auto]: Even when a new card is inserted, the file numbers are retained from the previous card. File numbering continues from the last number used or from the highest number available on the card.</p> <p>[Reset]: When you insert a new card, the folder numbers starts at 100 and the file name starts at 0001. If a card containing images is inserted, the file numbers start at the number following the highest file number on the card.</p>	—
Edit Filename	<p>Choose how image files are named by editing the portion of the filename highlighted below in gray.</p> <p>sRGB: Pmdd0000.jpg _____ Pmdd</p> <p>AdobeRGB: _mdd0000.jpg _____ mdd</p> <ul style="list-style-type: none"> • Select [Off] to use the default prefixes. 	—
dpi Settings	Choose the print resolution.	—
Copyright Settings*	<p>Add the names of the photographer and copyright holder to new photographs. Names can be up to 63 characters long.</p> <p>[Copyright Info.]: Select [On] to include the names of the photographer and copyright holder in the Exif data for new photographs.</p> <p>[Artist Name]: Enter the name of the photographer.</p> <p>[Copyright Name]: Enter the name of the copyright holder.</p> <div style="border: 1px solid gray; padding: 5px; margin: 10px 0;"> <p>1) Select characters from ① and press the OK button. The selected characters appear in ②.</p> <p>2) Repeat Step 1 to complete the name, then highlight [END] and press the OK button.</p> <ul style="list-style-type: none"> • To delete a character, press the INFO button to place the cursor in the name area ②, highlight the character, and press DEL. </div>  <p>* OLYMPUS does not accept liability for damages arising from disputes involving the use of [Copyright Settings]. Use at your own risk.</p>	—
Lens Info Settings	Save lens info for up to 10 lenses that do not automatically supply info to the camera.	239

Option	Description	
Quick Erase	If [On] is selected, pressing the button in the playback display will immediately delete the current image.	—
RAW+JPEG Erase	Choose the operation performed when pictures recorded at settings of RAW+JPEG are deleted using [Erase]. • Both the RAW and JPEG copies are deleted when selected images are deleted or when [All Erase] (P. 177) is selected. [JPEG]: Only the JPEG copy is erased. [RAW]: Only the RAW copy is erased. [RAW+JPEG]: Both copies are erased.	100, 132, 142
Priority Set	Choose the default selection ([Yes] or [No]) for confirmation dialogs.	—



I EVF

Option	Description	
EVF Auto Switch	[Off]: The viewfinder display does not light automatically when you put your eye to the viewfinder. Press the button to switch between the viewfinder and monitor displays. [On1]: The viewfinder display lights automatically when you put your eye to the viewfinder. Pressing the button displays [EVF Auto Switch] options. [On2]: Putting your eye to the viewfinder turns the viewfinder display on only if the monitor is closed. Pressing the button displays [EVF Auto Switch] options.	38
EVF Adjust	Adjust viewfinder brightness and hue. Brightness is automatically adjusted when [EVF Auto Luminance] is set to [On]. The contrast of the information display is also adjusted automatically.	—
EVF Style	Choose the viewfinder display style.	240
Info Settings	Choose the information that can be viewed by pressing the INFO button in the viewfinder display. It takes effect when [Style 1] or [Style 2] is selected for [EVF Style].	241

Option	Description	
EVF Grid Settings	<p>Choose the type and color of framing grid displayed in the viewfinder when [Off] is selected for [Grid Settings] > [Apply Settings to EVF] in  Custom Menu  and [Style 1] or [Style 2] is selected for [EVF Style]. Choose the framing grid from , , , ,  or .</p> <ul style="list-style-type: none"> When  is selected, the guides are adjusted for a 16:9 movie frame when movies are shot in still photography mode. Depending on the option selected for  , the guides may be displayed with an aspect ratio of 17:9. 	—
 Half Way Level	<p>Choose whether the level gauge can be displayed in the viewfinder by pressing the shutter button halfway when [Style 1] or [Style 2] is selected for [EVF Style].</p> <p>[On]: The level gauge is displayed in the viewfinder while the shutter button is pressed halfway. The level gauge appears in place of the exposure bar.</p> <p>[Off]: The level gauge is not displayed.</p>	—
S-OVF	<p>Select [On] to increase the dynamic range of the viewfinder display, increasing the amount of detail visible in highlights and shadows in a manner similar to optical viewfinders. Backlit subjects and the like are easier to see.</p> <ul style="list-style-type: none">  is displayed in the viewfinder when [S-OVF] starts. The display is not adjusted for settings such as white balance, exposure compensation, and picture mode. 	—

Option	Description	
Pixel Mapping	The pixel mapping feature allows the camera to check and adjust the image pickup device and image processing functions.	295
Press-and-hold Time	Choose the length of time buttons must be pressed to activate the “button hold” option.	241
Level Adjust	You can calibrate the angle of the level gauge. [Reset]: Reset the gauge to factory default settings. [Adjust]: Choose the current camera angle as the 0 position.	—
Touchscreen Settings	Activate the touch screen. Choose [Off] to disable the touch screen.	—
Menu Recall	Set [Recall] to display the cursor at the last position of operation when you display a menu. The cursor position will be retained even when you turn off the camera.	—
Fisheye Compensation	Correct fisheye distortion when shooting with fisheye lenses.	242

Option	Description	
Battery Settings	[Battery Priority]: Choose which battery is used first. When [Body Battery] is selected, the battery in the body takes priority. When [PBH Battery] is selected, the battery in the PBH (Power Battery Holder) takes priority. [Battery Status]: View the status of the batteries inserted in the camera.	—
Backlit LCD	Choose the length of time before the monitor backlight dims when no operations are performed. Dimming the backlight reduces the drain on the battery. • Choose from [Hold], [8sec], [30sec], and [1min]. The backlight will not dim if [Hold] is selected.	—

Option	Description	
Sleep	<p>Choose the delay before the camera enters sleep mode when no operations are performed. In sleep mode, camera operations are suspended and the monitor turns off.</p> <ul style="list-style-type: none"> • Choose from [Off], [1min], [3min], and [5min]. • The camera will not enter sleep mode if [Off] is selected. • Normal operation can be restored by pressing the shutter button halfway or by using the buttons or multi selector. • The camera will not enter sleep mode: <ul style="list-style-type: none"> while a multiple exposure is in progress or while connected to an HDMI device, smartphone, or via Wi-Fi or USB to a computer 	32
Auto Power Off	<p>The camera will turn off automatically if no operations are performed for a set time after it has entered sleep mode. This option is used to choose the delay before the camera turns off automatically.</p> <ul style="list-style-type: none"> • Choose from [Off], [5min], [30min], [1h], and [4h]. • The camera will not turn off automatically if [Off] is selected. • To reactivate the camera after it has turned off automatically, turn the camera on using the ON/OFF lever. 	32
Quick Sleep Mode	<p>If [On] is selected, the camera will enter power-saving mode more quickly when the live view display in the monitor is off. [Backlit LCD] and [Sleep] can be set to shorter intervals than normal.  is displayed in the monitor while power-saving is in effect.</p> <ul style="list-style-type: none"> • Power saving is not available: <ul style="list-style-type: none"> during live view photography, while the viewfinder is on, while multiple exposure or interval timer photography is in progress, or while connected to an HDMI device, smartphone, or via Wi-Fi or USB to a computer 	—
Certification	Display certification icons.	—

MENU → * → [A1] → [📷 AF+MF]

After focusing using autofocus, you can adjust focus manually by keeping the shutter button pressed halfway and rotating the focus ring. Switch from auto to manual focus at will or fine-tune focus manually after focusing with autofocus.

- The procedure varies with the AF mode selected.
- [Off] is selected by default.

On	<p>Enable manual focus adjustment in autofocus mode. MF is displayed next to [S-AF], [C-AF], [C-AF+TR], or [📷 AF].</p> <ul style="list-style-type: none"> • When [S-AF MF] is selected, you can keep the shutter button pressed halfway after focusing using single AF and adjust focus manually. Alternatively, you can switch to manual focus by rotating the focus ring while the camera is focusing. Focus can also be adjusted manually while the shutter is open and during burst photography in [Sequential Low] mode. • When [C-AF MF] or [C-AF+TR MF] is selected, you can switch to manual focus by rotating the focus ring while the camera is focusing in continuous AF and continuous tracking AF modes. Press the shutter button halfway a second time to refocus using autofocus. Focus can also be adjusted manually while the shutter is open and during burst photography in [Sequential Low] mode. • When [📷 AF MF] is selected, you can focus manually after focusing or before initiating focus using autofocus.
Off	Manual focus adjustment disabled during autofocus.

- Autofocus with manual focus is also available when autofocus is assigned to other camera controls. 📷 * Custom Menu [A1] > [📷 AEL/AFL] (P. 201)
- The lens focus ring can be used to interrupt autofocus only when M.ZUIKO PRO (Micro Four Thirds PRO) lenses are used. For information on other lenses, visit the OLYMPUS website.
- In **B** (bulb) mode, manual focus is controlled by the option selected for [Bulb/Time Focusing].

Setting Focus and Exposure with the **AEL/AFL** Button



MENU → * → **AF** → [**AEL/AFL**]

Choose how the camera sets focus and exposure when the shutter button or **AEL/AFL** button is pressed. The camera normally focuses and locks exposure when the shutter button is pressed halfway, but this can be changed according to the subject or shooting conditions.

S-AF	
C-AF	Choose the focus or metering operation performed using the shutter or AEL/AFL button (P. 202).
MF	
[AF]	
Half Way AF	
Face Priority AF	Choose whether the AEL/AFL and shutter buttons perform the same or different functions when faces are detected. If [On] is selected, the camera will focus on faces or eyes when the AEL/AFL button is pressed. If [Off] is selected, the camera will instead focus on the current AF target.

The table below shows how this setting interacts with [Half Way AF].

- “1” indicates the operation performed when [Half Way AF] is enabled, “2” the operation performed when it is disabled.

AEL/AFL mode		Shutter button pressed				AEL/AFL button	
		Halfway		All the way down		Kept pressed	
		AF	AE	AF	AE	AF	AE
S-AF	mode1	S-AF	Locks	—	—	—	Locks
	mode2	S-AF	—	—	Locks	—	Locks
	mode3	1: S-AF 2: —	Locks	—	—	S-AF	—
C-AF	mode1	C-AF	Locks	Ends	—	—	Locks
	mode2	C-AF	—	Ends	Locks	—	Locks
	mode3	1: C-AF 2: —	Locks	Ends	—	C-AF	—
	mode4	1: C-AF 2: —	—	Ends	Locks	C-AF	—
MF	mode1	—	Locks	—	—	—	Locks
	mode2	—	—	—	Locks	—	Locks
	mode3	—	Locks	—	—	S-AF	—
[Star]AF*	mode1	[Star]AF	Locks	—	—	—	Locks
	mode2	—	Locks	—	—	[Star]AF	—
	mode3	—	Locks	—	—	[Star]AF start/ end	—

* The behavior of [Star]AF is affected by the option selected for [Starry Sky AF Setting] (P. 184).

MENU → **⚙️** → **A1** → [📷 C-AF Sensitivity]

Choose how rapidly the camera responds to changes in the distance to the subject while focusing with [C-AF], [C-AF **MF**], [C-AF+TR], or [C-AF+TR **MF**] selected for [📷 AF Mode]. This can help autofocus track a quickly-moving subject or prevent the camera refocusing when an object passes between the subject and the camera.

- Choose from five levels of tracking sensitivity.
- The higher the value, the higher the sensitivity. Choose positive values for subjects that suddenly enter the frame, that are moving rapidly away from the camera, or that change speed or stop suddenly while moving toward or away from the camera.
- The lower the value, the lower the sensitivity. Choose negative values to prevent the camera refocusing when the subject is briefly obscured by other objects or to prevent the camera focusing on the background when you are unable to keep the subject in the AF target.

- 1 Highlight [📷 C-AF Sensitivity] in **⚙️** Custom Menu **A1** and press the **OK** button.

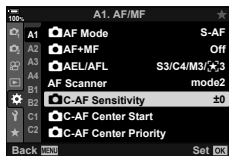

- 2 Highlight a setting using the **Δ**/**∇** buttons and press the **OK** button.
 - **⚙️** Custom Menu **A1** will be displayed.

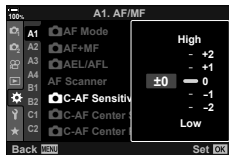

- 3 Press the **MENU** button repeatedly to exit the menus.

C-AF Starting Focus Target

(C-AF Center Start)

MENU → → **A1** → [C-AF Center Start]

When used in combination with an AF-target mode other than single target, [C-AF], [C-AF], [C-AF+TR], and [C-AF+TR] focus on the center of the selected group only during the initial scan. During later scans, the camera will focus using the surrounding targets. Combining this option with an AF-target mode that covers a wide area makes it easier to focus on erratically-moving subjects.

- 1 Highlight [C-AF Center Start] in Custom Menu **A1** and press the button.

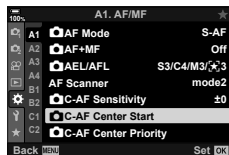

- 2 Using the buttons, highlight the AF target modes to which [C-AF Center Start] will apply and then press the button.

- Selected modes are marked with a check (). To deselect, press the button again.

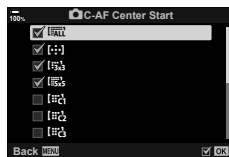



- 3 Press the **MENU** button repeatedly to exit the menus.





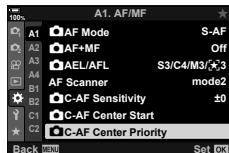

- This option is not available when [C-AF Center Priority] (P. 205) is enabled.

MENU →  → **A1** →  **C-AF Center Priority**

When focusing using group-target AF in [C-AF] and [C-AF MF] modes, the camera always assigns priority to the center target in the selected group for a repeated series of focus operations. Only if the camera is unable to focus using the center focus target will it focus using the surrounding targets in the selected focus group. This helps you track subjects that are moving quickly but relatively predictably. Center priority is recommended in most situations.

- 1 Highlight  C-AF Center Priority in  Custom Menu **A1** and press the  button.



- 2 Using the   buttons, highlight the AF target modes to which  C-AF Center Priority will apply and then press the  button.
 - Selected modes are marked with a check (). To deselect, press the  button again.



- 3 Press the **MENU** button repeatedly to exit the menus.

MENU → * → A2 → [[::]] Set Home

Choose the home position for the [[::]] Home feature. The [[::]] Home feature lets you recall a previously-saved “home position” for autofocus at the touch of a button. This item is used to choose the home position. To access [[::]] Home, assign it to a control using [📷 Button Function] (P. 116). You also have the option of assigning it to the multi selector using [📷 Center Button] (P. 217). If [📷 Orientation Linked [[::]]] (P. 210) is active, the camera will store separate home positions for landscape (wide) and portrait (tall) orientations. [HP] appears in the AF-target selection display when the current home position is selected.

- This item is for still photography.

AF Mode	Choose the home position autofocus mode. [S-]AF and [S-]AF MF cannot be assigned home positions.
AF Target Mode	Choose the home position AF target mode. Only options selected for [📷 [[::]] Mode Settings] (P. 182) are available.
AF Target Point	Choose the home position focus target.

- 1 Highlight [[::]] Set Home in * Custom Menu A2 and press the [OK] button.

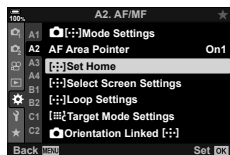

- 2 Highlight a setting you wish to store with the home position and press the [OK] button.

- Selected items are marked with a check (✓). Items marked with a ✓ are included in the home position.

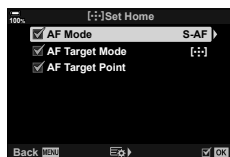

- 3 Press [▶] on the arrow pad to display options for the highlighted setting.

- Choose settings for the home position.
- When [📷 Orientation Linked [[::]]] is active, you will be prompted to select landscape or portrait (camera rotated left/camera rotated right) orientation before pressing the [▶] button to display options.

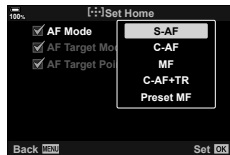

- 4 Press the [OK] button to save changes when settings are complete.
- The camera will return to the “[[::]] Set Home” display.

- 5 Press the **MENU** button repeatedly to exit when settings are complete.

AF-Target Selection ([::]) Select Screen Settings)

MENU → * → A2 → [::] Select Screen Settings]

Choose the roles played by the front and rear dials or arrow pad during AF target selection. The controls used can be selected according to how the camera is used or personal taste. You can choose up to two combinations.

- This item applies during both still photography and movie recording.
- If you select [Set 2], the options in the [::] Select Screen Settings] menu will be checked (✓). [Set 2] can be recalled by pressing the **INFO** button in the AF-target selection display.

Available Controls

Front dial, rear dial, △ ▽ on the arrow pad, the ◀ ▶ buttons.

Available Roles

[☑Pos]: Position the AF target (P. 72).

[::]Mode]: Choose the AF target mode (e.g., all, small, or group) (P. 69).

[☉]: Adjust settings for face/eye detection AF (P. 92).

MENU → * → A2 → [:·:] Loop Settings]

You can choose whether AF-target selection “wraps around” the edges of the display. You can also choose whether you have the option of selecting [ALL] (all targets) before AF-target selection “wraps around” to the opposite border of the display.

<p>[:·:] Loop Selection</p>	<p>[Off]: Wrap disabled. Target selection stays within the borders of the display.</p> <p>[Loop 1]: If you continue to press the multi selector in the same direction after reaching the border of the display, the target in the same row or column on the opposite border will be selected.</p> <p>[Loop 2]: If you continue to press the multi selector in the same direction after reaching the border of the display, the target in the next row or column on the opposite border will be selected.</p> <div data-bbox="702 342 927 720"> <p style="text-align: center;">"Loop 1"</p> <p style="text-align: center;">"Loop 2"</p> </div>
<p>Via [ALL]</p>	<p>[No]: Target selection does not pass through [ALL] (all targets) before wrapping around.</p> <p>[Yes]: If [Loop 1] or [Loop 2] is chosen for [:·:] Loop Selection, target selection will pass through [ALL] (all targets) before wrapping around to the opposite border.</p> <ul style="list-style-type: none"> • Hiding [ALL] (all targets) in [Mode Settings] fixes [Via [ALL]] at [No].

- [:·:] Loop Settings] is fixed at [Off] during movie recording and when [AF] is selected for focus mode.

AF Target Size and Positioning (Target Mode Settings)

MENU → * → A2 → [Target Mode Settings]

Choose the number of AF targets available and how far the AF target moves during AF-target selection. Targets can be larger than group targets or sized for subjects whose motion can be predicted. You can also increase the distance between available targets for faster target selection. The camera can store up to four different combinations of settings.

- If the AF-target or step size is altered from the default value, checks (✓) will appear next to the custom target options in [Mode Settings] (P. 182).
- This item is for still photography.

Size	Choose the target size. Target width and height can be set separately. Choose from options of 1, 3, 5, 7, 9, and 11.
Step	Choose the number of steps the target moves during target selection. The horizontal and vertical step sizes can be set separately; choose from steps of 1, 2, and 3.

Matching AF-Target Selection to Camera Orientation

(📷 Orientation Linked [:::])

MENU → ⚙ → A2 → [📷 Orientation Linked [:::]]

The camera can be configured to change the AF-target position and AF-target mode automatically when it detects that it has been rotated between landscape (wide) or portrait (tall) orientations. Rotating the camera changes the composition and consequently also the position of the subject in the frame. The camera can store the AF target mode and AF target position separately according to camera orientation. When this option is active, [:::] Set Home] (P. 206) can be used to store separate home positions for landscape and portrait orientations.

AF Target Mode	Choose separate AF target modes (e.g., all, small, or group) for landscape and portrait orientations.
AF Target Point	Choose separate AF targets for landscape and portrait orientations.

- 1 Highlight [📷 Orientation Linked [:::]] in ⚙ Custom Menu A2 and press ▷ on the arrow pad.

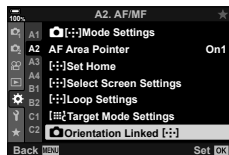

- 2 Highlight a setting you wish saved separately and press the OK button.
 - Selected items are marked with a check (✓).

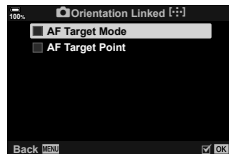



- 3 Press the **MENU** button repeatedly to exit when settings are complete.
 - Press the **MENU** button repeatedly to exit the menus.
- 4 Choose the AF target mode or target position with the camera first in one orientation and then the other.
 - Separate settings are stored for landscape orientation, portrait orientation with the camera rotated to the right, and portrait orientation with the camera rotated to the left.

MENU → * →  → [AF Limiter]

Choose the range in which the camera will focus using autofocus. This is effective in situations in which an obstacle presents itself between the subject and the camera during the focus operation, causing drastic changes in focus. You can also use it to prevent the camera focusing on foreground objects when shooting through a fence, window, or the like.

Distance settings	Choose the range of focus distances available. The camera can store up to three settings for different situations. Distances are approximate and intended as guides only.
Release Priority	The shutter can still be released if the camera is unable to focus when [On] is selected for [AF Limiter].



- [AF Limiter] can be assigned to a button. You then need only press the button to limit focus range. Hold the button and rotate a dial to choose from the three stored settings.  “Assigning functions to buttons (Button Function)” (P. 116)
- AF Limiter is not available in the following cases.
 - When the focus limiter is enabled on the lens
 - When using focus bracketing
 - While in the movie mode or recording a movie
 - When []AF or []AF MF is selected for focus mode

MENU → **☼** → **A3** → **[AF Focus Adj.]**

Fine-tune phase-detection autofocus. Focus can be fine-tuned by up to ± 20 steps.

- Normally there is no need to fine-tune autofocus using this item. Fine-tuning focus may prevent the camera focusing normally.
- Focus fine-tuning has no effect in [S-AF] and [S-AF MF] modes.
- This item is for still photography.

Off	Fine-tuning disabled.
Default Data	Fine-tune focus for all lenses.
Lens Data	Save fine-tuning values on a lens-by-lens basis. The camera can store fine-tuning values for up to 20 lenses. Focus for individual lenses can be fine-tuned in specific areas of the frame. In the case of zoom lenses, separate values can be stored for long and short focal lengths.

- 1 Highlight [AF Focus Adj.] in **☼** Custom Menu **A3** and press **▷** on the arrow pad.

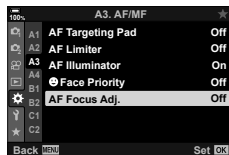

- 2 Highlight [Default Data] or [Lens Data] and press the **▷** button.

- If you selected [Default Data], proceed to Step 5.
- To disable fine-tuning, highlight [Off] and press the **OK** button.



- 3 Highlight [Create Lens Data Set] and press the **OK** button.

- You will be prompted to choose the area of the frame for which focus will be fine-tuned.

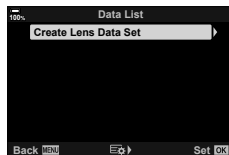

- 4 Use the **△** **▽** **◀** **▶** buttons to choose an area of the frame and then press the **OK** button.

- With zoom lenses, you can press the **INFO** button to choose between long (telephoto) and short (wide) focal lengths.



- 5** Choose a fine-tuning value using the Δ ∇ buttons and press the OK button.
- The selected value will be saved. If you chose [Default Data], the options shown in Step 2 will be displayed.
 - If you chose [Lens Data], the dialog shown in Step 3 will be displayed. The display will show the name of the lens for which the fine-tuning value was saved.
 - Rotate the front dial to zoom in and check focus.
 - Before pressing the OK button, press the shutter button to take a test shot and check focus.
 - To save another fine-tuning value for the current lens, press the \triangleright button and repeat the process from Step 4.
- 6** To fine-tune focus for the same lens but in a different area of the frame, highlight the lens name using the Δ ∇ buttons and press the \triangleright button.
- Repeat the process from Step 4.

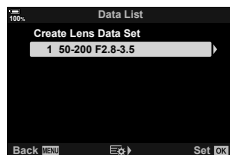

- 7** When the process is complete, press the **MENU** button repeatedly to exit the menus.

■ Deleting Saved Values

- 1** Highlight [AF Focus Adj.] in CUSTOM Menu **A3** and press \triangleright on the arrow pad.

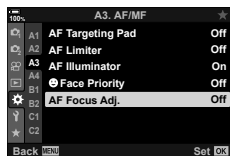

- 2** Highlight [Lens Data] using the Δ ∇ buttons and press the \triangleright button.



- 3** Use the Δ ∇ buttons to highlight the name of the lens you wish to delete from the fine-tuning list and then press the \triangleright button.

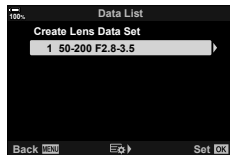

- 4 Highlight [Delete] using the Δ ∇ buttons and press the \triangleright button.

- A confirmation dialog will be displayed.

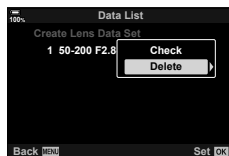

- 5 Highlight [Yes] using the Δ ∇ buttons and press the OK button.

- The dialog shown in Step 3 will be displayed. Confirm that the lens name has been deleted.



- To disable AF fine-tuning without deleting the entries for the current lens, select [Off] for [AF Focus Adj.].



- The camera can store multiple values for each lens.



■ Enabling Fine-Tuning

Display the lens data list and place checks (✓) next to the items you wish to use.

MENU → * → A4 → [MF Assist]

This is a focus assist function for MF. When the focus ring is rotated, the edge of the subject is enhanced or a portion of the screen display is magnified. When you stop operating the focus ring, the screen returns to the original display.

- This item applies during both still photography and movie recording.

Magnify	Magnifies a portion of the screen. The portion to be magnified can be set in advance using AF target.  "Choosing a Focus Target (AF Target Point)" (P. 72)
Peaking	Displays clearly defined outlines with edge enhancement. You can select the enhancement color and intensity.  * Custom Menu D3 > [Peaking Settings] (P. 189)

- Rotate the front or rear dial to zoom in or out during focus zoom.
- [Peaking] can be displayed using button operations. The display is switched every time the button is pressed. Focus peaking must first be assigned to a button using [Button Function] (P. 116).
- Press the **INFO** button to change the color and intensity when Peaking is displayed.
- When Peaking is in use, the edges of small subjects tend to be enhanced more strongly. This is no guarantee of accurate focusing.
- Focus zoom is not available during movie recording or when [C-AF **MF**] or [C-AF+TR **MF**] is selected for focus mode.

Adjusting Focus During Exposures (Bulb/Time Focusing)

MENU → * → A4 → [Bulb/Time Focusing]

You can adjust focus manually while shooting in **B** (bulb) mode. This allows you to defocus during the exposure or focus at the end of the exposure.

- 1 Highlight [Bulb/Time Focusing] in * Custom Menu A4 and press the \odot button.

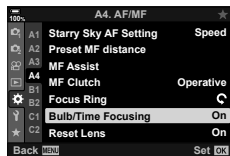







- 2 Highlight an option using the Δ ∇ buttons.
[Off]: The focus position cannot be adjusted manually during an exposure.
[On]: The focus position can be adjusted manually during an exposure.
- 3 Press the \odot button to select the highlighted option.
 - * Custom Menu A4 will be displayed.
- 4 Press the **MENU** button repeatedly to exit the menu.

Multi Selector Press

( Center Button)

MENU → → **B1** → [Center Button]

Choose the operation performed by pressing the multi selector. The multi selector can then function as a button.

Off	No role assigned. Pressing the multi selector has no effect.
[] (AF target selection)	Press the multi selector to adjust settings for AF target selection, AF target mode, or face priority AF. The arrow pad or front and rear dials can be used according to the setting selected for [ Select Screen Settings] (P. 207) in  Custom Menu A2 . <ul style="list-style-type: none"> • This item applies during both still photography and movie recording.
[] Home (AF area HOME)	The multi selector performs the function selected for [ Button Function] > [ Home] (P. 118). <ul style="list-style-type: none"> • This option applies in still photography modes only.

Multi Selector Tilt

( Direction Key)

MENU → → **B1** → [Direction Key]

Choose the operation performed by tilting the multi selector. The multi selector is normally used to position the AF target, but this function can be disabled to prevent unintended operation.





- This item applies during both still photography and movie recording.

Off	Pressing the multi selector up, down, left, or right has no effect.
[] (AF-target position)	The multi selector can be used to position the AF-target (P. 72).





Assigning Roles to the Front and Rear Dials Dial Function)

MENU → → **B1** → Dial Function]

Choose the roles performed by the front and rear dials. You can also choose the function selected using the **Fn** lever (P. 219). You can also choose the operations performed during playback or when menus are displayed.

- This item is for still photography. The functions assigned using  Button/Dial/Lever >  Dial Function] (P. 163) in the  video menu take effect in  (movie) mode.

The roles that can be performed by the dials in photo shooting and  playback modes are listed below.

Role	Function	Shooting mode				
		P	A	S	M	B
Ps	Program shift (P. 45).	✓	—	—	—	—
Shutter	Choose the shutter speed.	—	—	✓	✓	✓*
FNo.	Adjust aperture.	—	✓	—	✓	✓
	Adjust exposure compensation.	✓	✓	✓	✓	✓
	Adjust flash compensation.	✓	✓	✓	✓	✓
ISO	Adjust ISO sensitivity.	✓	✓	✓	✓	✓
WB	Adjust white balance.	✓	✓	✓	✓	✓
CWB Kelvin	Choose a color temperature when CWB (custom) is selected for white balance.	✓	✓	✓	✓	✓
Off	None.	✓	✓	✓	✓	✓
 /Value	Move the cursor up or down or highlight values or options while menus are displayed.	—				
	Move the cursor left or right while menus are displayed.					
 Q (index/playback zoom)	Zoom in or out or switch to the index display during playback.	—				
Prev/Next	View the next or previous image during playback.					

* Switch between bulb, time, and live composite.

MENU → ⚙️ → [B1] → [📷 Fn Lever Function]

Choose the role played by the **Fn** lever.

- This item is for still photography. The functions assigned to controls using this item are available only in modes **P**, **A**, **S**, **M**, and **B** (still photography modes). The functions assigned using [📷 Button/Dial/Lever] > [📷 Fn Lever Function] (P. 163) in the 📷 video menu take effect in 📷 (movie) mode.

mode1	Switch the functions of the front and rear dials. The functions for Positions 1 and 2 conform to the setting selected for [📷 Dial Function] (P. 218).
mode2	Switch between two groups of settings previously selected for [AF Mode], [AF Target Mode], and [AF Target Point]. • You can choose the options selected by pressing ▷ on the arrow pad.
mode3	Toggle the shooting mode. You can switch to 📷 (movie) mode without rotating the mode dial. • The Fn lever cannot be used to perform the function assigned using [📷 Fn Lever Function].
Off	The Fn lever function is turned off.

- The **Fn** lever cannot be used to perform the selected function when [Power 1] or [Power 2] is selected for [Fn Lever/Power Lever] (P. 185) in ⚙️ Custom Menu [B1].

Burst Shooting Options































(L Settings / H Settings)

MENU → ⚙ → → [L Settings] / [H Settings]

Adjust settings for sequential shooting modes, including the maximum frame advance rate and number of shots per burst. Shooting ends if the maximum number of shots is reached while the shutter button is pressed all the way down.

Choose the advance rate and number of shots per burst for (sequential low) and (sequential high) modes.

<p> L Settings (sequential low options)</p>	<p>Choose the frame rate and maximum number of shots per burst for (sequential low), (anti-shock sequential low), and (silent sequential low) modes. You can also adjust settings for (Pro Capture Low) mode (P. 81).</p> <ul style="list-style-type: none"> • and modes: [Max fps]: 1–10 fps [Frame Count Limiter]: 2–99, Off (no limit) • mode: [Max fps]: 1–10, 15, or 18 fps [Frame Count Limiter]: 2–99, Off (no limit) • mode: [Max fps]: 10, 15, or 18 fps [Pre-shutter Frames]: 0–35 [Frame Count Limiter]: 2–99, Off (no limit) Includes shots captured before recording begins.
<p> H Settings (sequential high options)</p>	<p>Choose the frame rate and maximum number of shots per burst for (sequential high) and (silent sequential high) modes. You can also adjust settings for (Pro Capture High) mode (P. 82).</p> <ul style="list-style-type: none"> • mode: [Max fps]: 10–15 fps [Frame Count Limiter]: 2–99, Off (no limit) • mode: [Max fps]: 15, 20, 30, or 60 fps [Frame Count Limiter]: 2–99, Off (no limit) • mode: [Max fps]: 15, 20, 30, or 60 fps [Pre-shutter Frames]: 0–35 [Frame Count Limiter]: 2–99, Off (no limit) Includes shots captured before recording begins.

- 1 Highlight [Custom Settings] or [Custom Settings] in  and press the  button.
 - Custom Menu 
- 2 Highlight an option using the   buttons and press the  button.
 - The camera will display options for the selected item.
- 3 Choose a setting for [Max fps].
 - Highlight [Max fps] using the   buttons and press the  button.
 - Highlight an option using the   buttons and press the  button.
- 4 Choose a setting for [Pre-shutter Frames].
 - This option will only be available if you selected [Pro] in Step 2.
 - Highlight [Pre-shutter Frames] using the   buttons and press the  button.
 - Highlight an option using the   buttons and press the  button.
- 5 Choose the maximum number of shots per burst ([Frame Count Limiter]).
 - Highlight [Frame Count Limiter] using the   buttons and press the  button.
 - To keep shooting as long as the shutter release button is pressed all the way down, select [Off].
 - To choose a maximum number of shots, highlight the current setting and press the  button to display options. Highlight digits using the   buttons and use the   buttons to change.
 - The maximum number of shots per burst includes shots captured while the shutter button is pressed halfway.  “Shooting without a release time lag (Pro Capture shooting)” (P. 81)
 - Press the  button to save changes to settings.
- 6 Press the  button.
 -  Custom Menu  will be displayed.
- 7 Press the **MENU** button repeatedly to exit the menus.

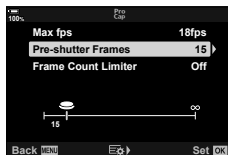
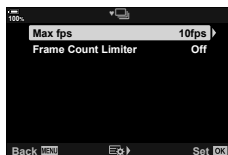

Pro Capture options

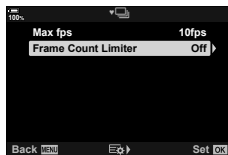

MENU → **⚙** → **C1** → **[Flicker Reduction]**

When shooting under fluorescent or other artificial workplace or outdoor lighting, you may notice flicker in the live view display or uneven exposure in photos taken at fast shutter speeds. This item reduces these effects.

■ Reducing Flicker in Live View (Anti-Flicker LV)

Reduce flicker under fluorescent lighting and the like. Choose this option if flicker makes the display difficult to view.

Auto	The camera detects and reduces flicker.
50Hz	Reduce flicker under workplace or outdoor lighting powered by alternating current with a frequency of 50 Hz.
60Hz	Reduce flicker under workplace or outdoor lighting powered by alternating current with a frequency of 60 Hz.
Off	Flicker reduction off. • This option is not available when [On] is selected for [Anti-Flicker Shooting] (P. 223).

- 1 Highlight [Flicker Reduction] in **⚙** Custom Menu **C1** and press the **OK** button.

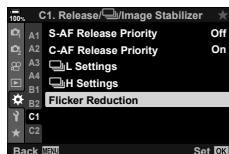

- 2 Highlight [Anti-Flicker LV] using the **Δ** **∇** buttons and press the **▷** button.
 - [Anti-Flicker LV] options will be displayed.

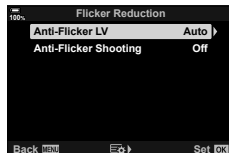

- 3 Highlight an option using the **Δ** **∇** buttons and press the **OK** button.
 - [Flicker Reduction] options will be displayed.



- 4 Press the **MENU** button repeatedly to exit the menus.

■ Reducing Flicker in Photographs (Anti-Flicker Shooting)

You may notice uneven exposure in photos taken under flickering light. When this option is enabled, the camera will detect the flicker frequency and adjust the timing of the shutter release accordingly. This feature applies to photos taken with the mechanical shutter.

- 1 Highlight [Flicker Reduction] in **Custom Menu C1** and press the **OK** button.

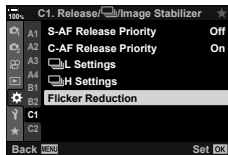

- 2 Highlight [Anti-Flicker Shooting] using the **Δ** **▽** buttons and press the **▷** button.
 - [Anti-Flicker Shooting] options will be displayed.

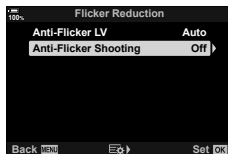

- 3 Highlight [On] or [Off] using the **Δ** **▽** buttons and press the **OK** button.
 - [Flicker Reduction] options will be displayed.

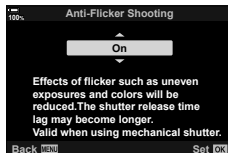

- 4 Press the **MENU** button repeatedly to exit the menus.
 - A **FLK** icon appears in the display when [On] is selected.



- This option does not take effect in modes that use the electronic shutter, including silent modes, High Res Shot, and Pro Capture modes.
- The camera may be unable to detect flicker at some settings. Normal release timing will be used if flicker is not detected.
- Normal release timing is used at slow shutter speeds.
- Enabling flicker reduction may cause release lag, slowing the frame advance rate during burst photography.

Choosing the control panel displays (Control Settings)

MENU → * → [D1] → [Control Settings]

Choose the control panel displays available in each shooting mode. Use this option to hide on-screen controls (live controls and the LV super control panel) so that they cannot be displayed via the **INFO** button.

- 1 Highlight [Control Settings] in * Custom Menu [D1] and press the **OK** button.

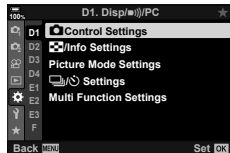

- 2 Highlight items using the Δ ∇ buttons and press the **OK** button.
 - Selected items are marked with a check (✓). Selected items will be displayed.

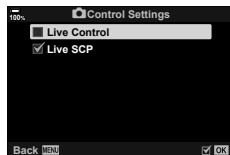

- 3 Press the **MENU** button repeatedly to exit the menus.

- For movie mode, set with [Control Settings] of [Display Settings] (P. 164).

■ Displaying On-Screen Controls

- At default settings, live controls are hidden during still photography. To toggle between live controls and the LV super control panel, you must first place a check (✓) next to both [Live Control] and [Live SCP] in the [Control Settings] display.

- 1 Press the **OK** button during live view in **P**, **A**, **S**, **M**, or **B** mode.
 - The LV super control panel will be displayed.



OK

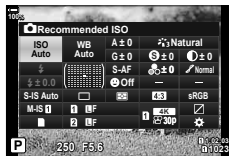

2 Press the **INFO** button to display live controls.

- The on-screen controls displayed change each time the **INFO** is pressed.

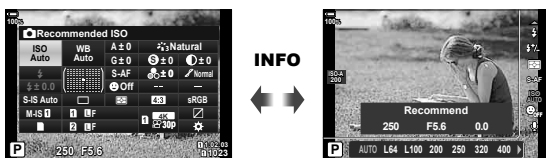

3 After adjusting settings, press the **OK** button to exit the on-screen controls.

- Pressing the **OK** button will in future display the last on-screen controls used.

- The **INFO** button cannot be used to toggle on-screen controls if it can be used to display options for the item currently selected in the live control display. Select a different item before using the **INFO** button to toggle the display.

■ Live control



Available settings

Image stabilizer*.....P. 97	☞ mode (movie exposure mode)*P. 165
Picture mode*.....P. 106, 142	Flash mode.....P. 86
White balance*.....P. 94	Flash intensity control.....P. 105
Sequential shooting/Self-timer.....P. 78, 98	Metering mode.....P. 77
Aspect ratio.....P. 98	AF mode*.....P. 64
📷⏪ (image quality)*	ISO sensitivity*P. 75, 91
Still imageP. 100	Face priority*P. 92
MovieP. 101	Movie sound record*.....P. 169

* Available in movie mode

- Some functions cannot be used depending on the shooting mode.
- When the controls in [📷 Control Settings] is set to [Live Control], you can use live control even in **P**, **A**, **S**, **M**, **B** modes (P. 224).

1 Press the **OK** button to display the live control.

- Press the **OK** button again to hide live control.

2 Use **Δ**/**∇** to move the cursor to the desired function, then use **◀**/**▶** to select it and press the **OK** button.

- The setting is confirmed if you leave the camera as-is for 8 seconds.

MENU → * → [D1] → [Info]/Info Settings]

■ [Info] Info (Playback information displays)

Use [Info] to add the following playback information displays. The added displays are displayed by repeatedly pressing the **INFO** button during playback. You can also choose to not show displays that appear at the default setting.



Histogram display



Highlight & Shadow display



Light box display

Highlight & Shadow display

Areas above the upper limit of brightness for the image are shown in red, those below the lower limit in blue. [Info] * Custom Menu [D3] > [Histogram Settings] (P. 189)



Light box display

Compare two images side-by-side. Press the [OK] button to select the base image.

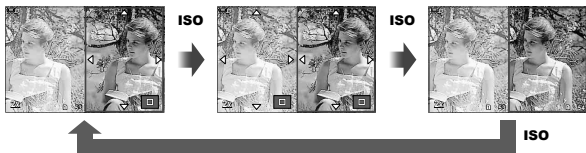
- The base image is displayed on the right. Use the front dial to select an image and press the [OK] to move the image to the left. The image to be compared to the image on the left can be selected on the right. To choose a different base image, highlight the right frame and press the [OK].
- To change the zoom ratio, turn the rear dial. Press the **ISO** button and then Δ ∇ <|> to scroll the zoomed-in area, and rotate the front dial to select between images.



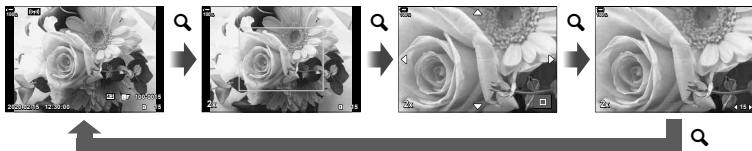

■ Info (Magnified playback information display)

The magnified playback information displays can be set with  Info. If  (Magnify) is assigned to a button with Button Function (P. 116) in advance, the set displays can be switched by repeatedly pressing the  button during playback. You can also choose to not show displays that appear at the default setting.



■ LV-Info (Shooting information displays)

Choose the info shown in the live view shooting display.  "Switching the information display" (P. 39)

To add highlights and shadows to the [LV-Info] display, press  on the arrow pad to place a check next to [Custom1] or [Custom2]. The added displays are displayed by repeatedly pressing the **INFO** button during shooting. You can also choose to not show displays that appear at the default setting.

To choose the information displayed when the shutter button is pressed halfway, select [LV-Info], highlight [Image Only] and press the  button.

On	Shooting info is displayed while the shutter button is pressed halfway.
Off	Shooting info is not displayed while the shutter button is pressed halfway.

■ LV OFF-Info (Shooting information displays)

Choose a shooting display (P. 40).

■ [Settings] (Index/calendar display)

You can change the number of frames to be displayed on the index display and set to not display the screens that are set to be displayed by default with [Settings]. Screens with a check can be selected on the playback screen using the rear dial.

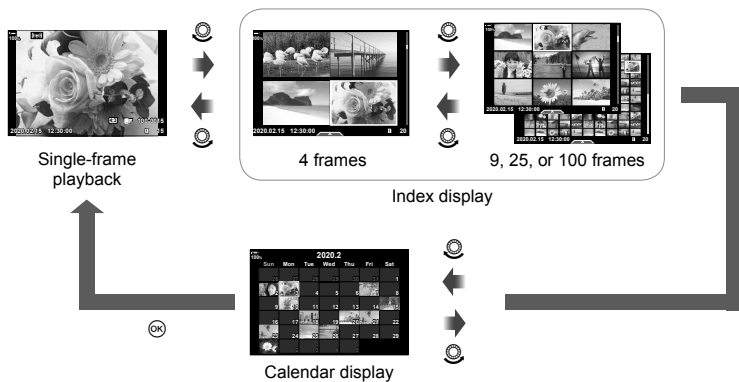

4

Menu functions (Custom menus)

Choosing the Playback Zoom Ratio (▶🔍 Default Setting)

MENU → * → D2 → [▶🔍 Default Setting]

Choose the starting zoom ratio for playback zoom (close-up playback).

Recently	Zoom in to the most recently selected zoom ratio.
Equally Value	Images are displayed at a zoom ratio of 1:1. A 1:1 icon appears in the monitor.
x2, x3, x5, x7, x10, x14	Choose the starting zoom ratio.

Selfie Assist (Selfie Assist)

MENU → * → D3 → [Selfie Assist]

Choose the display used when the monitor is reversed for self-portraits.

- This item applies during both still photography and movie recording.

On	When reversed for self-portraits, the monitor shows a mirror image of the view through the lens.
Off	The display does not change when the monitor is reversed.

- 1 Select [On] for [Selfie Assist] in * Custom Menu **D3**.
- 2 Turn the monitor towards you.

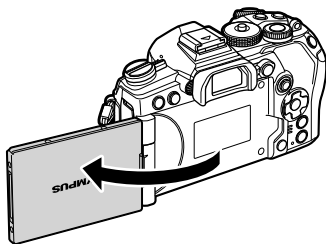

Viewing camera images on TV

(HDMI)

MENU → * → [D4] → [HDMI]

Use the separately sold cable with the camera to playback recorded images on your TV. This function is available during shooting. Connect the camera to an HD TV using an HDMI cable to view high-quality images on a TV screen.

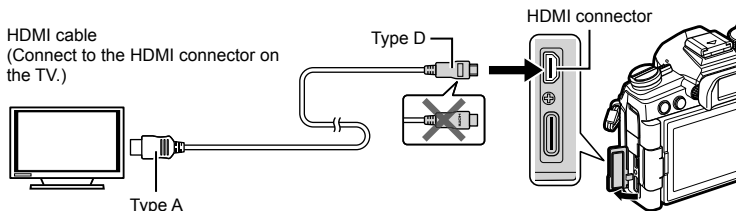

Connect the TV and camera and switch the input source of the TV.

- If [On] is selected for [HDMI Control] (P. 282), the camera monitor will turn off when an HDMI cable is connected.
- For details on changing the input source of the TV, refer to the TV's instruction manual.
- Depending on the TV's settings, the displayed images and information may become cropped.
- If the camera is connected via an HDMI cable, you will be able to choose the digital video signal type. Choose a format that matches the input format selected with the TV.

C4K	The signal is output in 4K digital cinema (4096 × 2160) format.
4K	If possible, the signal is output in 4K (3840 × 2160).
1080p	If possible, the signal is output in Full HD (1080p).
720p	If possible, the signal is output in HD (720p).
480p/576p	The signal is output in 480p/576p format.

- Do not connect the camera to other HDMI output devices. Doing so may damage the camera.
- HDMI output is disabled while the camera is connected to a computer via USB.
- When [Record Mode] is selected for [Output Mode] (P. 164), movies will be output at the resolution selected during recording. The images cannot be displayed on the connected TV if the TV does not support the record mode.
- 1080p output will be used in place of [4K] or [C4K] while the camera is being used to take photographs.

Using the TV remote control

The camera can be operated by a TV remote control when connected to a TV that supports HDMI control.  "Using a TV Remote (HDMI Control)" (P. 282)



The camera monitor turns off.

- You can operate the camera by following the operation guide displayed on the TV.
- During single-frame playback, you can display or hide the information display by pressing the "Red" button, and display or hide the index display by pressing the "Green" button.
- Some televisions may not support all features.

Choosing a USB Connection Mode (USB Mode)

MENU →  →  → **[USB Mode]**

Choose how the camera functions when connected to external devices via USB.

Auto	You will be prompted to choose a connection mode each time a USB cable is connected.
Storage	The camera functions as an external storage device. The data on the camera memory card can be copied to the computer.
MTP	The pictures on the memory card can be viewed or copied to the computer using standard software supplied with Windows.
 PC RAW	Employing computer controls available via Olympus Workspace, process pictures using the camera's high-speed image processing engine. You can also edit RAW pictures stored on memory cards inserted in the camera. Be sure to install and launch the latest version of Olympus Workspace on your computer (P. 274). <ul style="list-style-type: none">• RAW processing is not available with pictures taken with other cameras or when the camera battery is low.
	The camera can be controlled from the computer, while pictures shot using OLYMPUS Capture can be downloaded as they are taken. For more information, see "Connecting to Computers via USB" (P. 274).
USB PD	The camera can be powered by external devices connected via USB. For more information, see "Powering the Camera via USB (USB Power Delivery)" (P. 278).

Live Bulb Update Frequency (Live Bulb)

MENU → * → **E2** → **[Live Bulb]**

Choose the frequency with which the display is updated during live bulb photography in mode **B** (bulb). The display will be refreshed at the selected interval while live bulb photography is in progress, allowing you to view the results in the display.

- [Live Bulb] options can also be displayed by pressing the **MENU** button during [BULB] or [LIVE BULB] photography.

Live Time Update Frequency (Live Time)

MENU → * → **E2** → **[Live Time]**

Choose the frequency with which the display is updated during live time photography in mode **B** (bulb). The display will be refreshed at the selected interval while live time photography is in progress, allowing you to view the results in the display.

- [Live Time] options can also be displayed by pressing the **MENU** button during [TIME] or [LIVE TIME] photography.

Choosing the Shutter Speed (Composite Settings)

MENU → * → [E2] → [Composite Settings]

The exposure time for each exposure made during live composite photography can be chosen in advance using the menus.

- 1 Highlight [Composite Settings] in * Custom Menu [E2] and press the [OK] button.

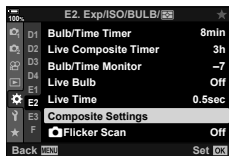

- 2 Highlight an option using the [Δ] [▽] buttons.
 - Choose an exposure time of from 1/2 to 60 s.



- 3 Press the [OK] button to select the highlighted option.
 - * Custom Menu [E2] will be displayed.

- 4 Press the **MENU** button repeatedly to exit the menus.

- The maximum exposure time can be selected using [Live Composite Timer] in * Custom Menu [E2] (P. 192). The default setting is [3h].
- This item applies during still photography in **B** (bulb) mode. See page 54 for more information on composite photography.
- [Composite Settings] options can also be displayed by pressing the **MENU** button in [LIVE COMP] mode.

Reducing Flicker Under LED Lighting (📷 Flicker Scan)

MENU → ⚙️ → [E2] → [📷 Flicker Scan]

Banding may occur in photographs taken under LED lighting. Use [📷 Flicker Scan] to optimize shutter speed while viewing banding in the display.

- This item is for still photography.
- This item can be used in **S**, **M**, and silent mode and with High Res Shot and Pro Capture shooting.
- The range of available shutter speeds is reduced.

1 Choose shooting and drive modes.

- Choose shooting mode **S** or **M**.
- Choose one of the following drive modes:
 - Silent mode (🔇, 📷, 📷_L, 📷_H, 📷_{2s}, 📷_{2s}, or 📷_{2c})
 - High Res Shot (📷)
 - Pro Capture (Pro_L or Pro_H)

2 Highlight [📷 Flicker Scan] in ⚙️ Custom Menu [E2] and press the [OK] button.

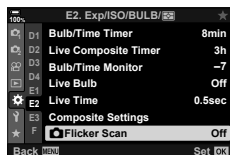

3 Highlight [On] using the [Δ] [▽] buttons and press the [OK] button.

- The camera will return to the previous menu.

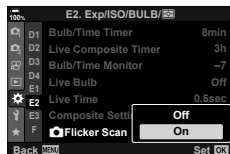

4 Press the **MENU** button repeatedly to exit the menus.

- The camera will exit to the shooting display. A **Flicker Scan** icon will be displayed.



Flicker Scan icon

- 5** Choose a shutter speed while viewing the display.
- Choose a shutter speed using the front or rear dial or the Δ ∇ buttons. If desired, the shutter speed can be selected by keeping Δ ∇ pressed.
 - You can also rotate the front dial to adjust shutter speed in the exposure increments selected for [EV Step] in **Custom Menu 3**.
 - Continue adjusting shutter speed until banding is no longer visible in the display.
 - Press the **INFO** button; the display will change and the **Flicker Scan** icon will no longer be displayed. You can adjust aperture and exposure compensation. Do so using the front or rear dial or the arrow pad.
 - Press the **INFO** button repeatedly to return to the flicker scan display.

6 Take pictures once settings have been adjusted to your satisfaction.

- Focus peaking, the LV super control panel, and live controls are not available in the flicker scan display. To view these items, first press the **INFO** button to exit the flicker scan display.



- [Flicker Scan] can be assigned to a button. You then need only press the button to enable flicker scan. "Assigning functions to buttons (Button Function)" (P. 116)

Fine-Tuning Exposure (Exposure Shift)

MENU → * → 3 → [Exposure Shift]

Fine-tune exposure. Use this option if you want the results of auto exposure to be consistently brighter or darker.

- This item applies during both still photography and movie recording.
- Fine-tuning is not normally required. Use only as necessary. In normal circumstances, exposure can be adjusted using exposure compensation (P. 68).
- Fine-tuning exposure reduces the amount of exposure compensation available in the direction (+ or -) exposure was fine-tuned.
- Exposure fine-tuning can be applied to the following metering methods.

Metering	Fine-tuning amount
(digital ESP)	-1 to +1 EV in steps of 1/6 EV
(center-weighted averaging)	
(spot)	

Shutter speeds when the flash fires (⚡ X-Sync./⚡ Slow Limit)

MENU → **⚙** → **Ⓛ** → [⚡ X-Sync.]/[⚡ Slow Limit]

You can set shutter speed conditions for when the flash fires.

- This item is for still photography.

Shooting mode	Flash firing shutter speed	Upper limit	Lower limit
P	The camera automatically sets the shutter speed.	[⚡ X-Sync.] setting	[⚡ Slow Limit] setting
A			
S	The set shutter speed		No lower limit
M			

Combinations of JPEG image sizes and compression rates (⏪ Set)

MENU → **⚙** → **Ⓜ** → [⏪ Set]

You can set the JPEG image quality by combining image size and compression rate.

- This item is for still photography.

Image size		Compression rate			Application
Name	Pixel Count	SF (Super Fine)	F (Fine)	N (Normal)	
L (Large)	5184×3888*	L SF*	L F*	L N*	Select for the print size
M (Middle)	3200×2400* 1920×1440	M SF	M F	M N*	
S (Small)	1280×960 1024×768	S SF	S F	S N	For small prints and use on a website









* Default

Setting the card to record to (Card Slot Settings)

MENU → * → [M] → [Card Slot Settings]



When there are cards in both slots 1 and 2, you can select which card to record still images and movies to.

- 1 Highlight [Card Slot Settings] in * Custom Menu [M] and press the [OK] button.
- 2 Use Δ ∇ to select the item and press ▷.
 - Use Δ ∇ to select the setting and press the [OK] button.

 Save Settings	Choose the recording method for still images.  “Setting the saving method for shooting data ( Save Settings)” (P. 99)
 Save Slot	Choose the card used to record photographs. This option takes effect when [Standard] or [Auto Switch] is selected for [ Save Settings].
 Save Slot	Choose the card used to record movies.
 Slot	Choose the card used for still image playback when [ Save Settings] is set to [Dual Independent ↓], [Dual Independent ↑], [Dual Same ↓], or [Dual Same ↑].
Assign Save Folder	Choose the destination folder. <ul style="list-style-type: none">• This option is also available when only one card is inserted.

- Settings other than [ Save Slot] and [Assign Save Folder] can only be accessed in still photography modes.



- You can also choose a card for playback using the [▶] button. Hold the [▶] button and rotate the front or rear dial to switch cards while playback is in progress. This does not change the option selected for [▶ Slot].
- When [] (Auto Switch) is selected for [ Save Settings], the camera will automatically switch between the last picture on the first card and the first picture on the second card.
- In [ (movie) mode, the slot selected for [ Save Slot] also serves as the [▶ Slot].

Assign Save Folder

- 1 Select [Assign Save Folder] and press \blacktriangleright .
- 2 Select [Assign] and press \blacktriangleright .
- 3 Select a folder and press the OK button.
 - If you select [New Folder], specify the 3-digit folder number and press the OK button.
 - If you select [Existing Folder], use Δ ∇ to select the existing folder and press the OK button.
The first 2 frames and the last frame in the selected folder are displayed.

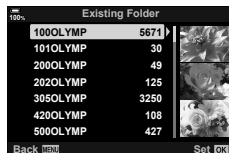

MENU → * → [Fn] → [Lens Info Settings]

The camera can store information for up to 10 lenses that do not conform to the Micro Four Thirds or Four Thirds system standards. These data also supply the focal length used for the image stabilization and keystone compensation features.

- This item applies during both still photography and movie recording.

1 Select [Create Lens Information] for [Lens Info Settings] in * Custom Menu [Fn].

2 Select [Lens Name] and enter a lens name. After entering a name, highlight [END] and press the [OK] button.

3 Use $\Delta \nabla \langle \triangleright$ to choose the [Focal Length].

4 Use $\Delta \nabla \langle \triangleright$ to choose the [Aperture Value].

5 Select [Set] and press the [OK] button.

- The lens will be added to the lens info menu.
- When a lens that does not supply info automatically is attached, the info used is indicated by checks (✓). Highlight lenses to which you want to add checks (✓) and press the [OK] button.



- [Lens Info Settings] can be assigned to a button. The button can then be used to recall lens info, for example after lenses are exchanged. "Assigning functions to buttons (Button Function)" (P. 116)

Selecting the display style of the viewfinder (EVF Style)

MENU → * → [] → [EVF Style]

Style 1/2: Similar to film camera viewfinder displays.

Style 3: The same as the monitor display.



Style 1/ Style 2



Style 3

■ Viewfinder display when shooting using the viewfinder (Style 1/Style 2)

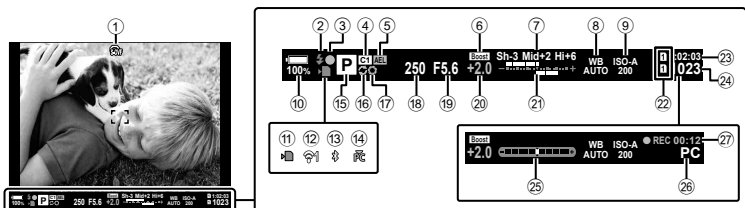

- | | |
|---|--|
| ① OVF simulation*1P. 197 | ⑮ Shooting mode..... P. 41–60 |
| ② Flash.....P. 84
(blinks: charging in progress, lights up:
charging completed) | ⑯ Pro Capture activeP. 81 |
| ③ AF confirmation mark.....P. 42 | ⑰ PreviewP. 117 |
| ④ Custom modeP. 57, 142 | ⑱ Shutter speedP. 44–50 |
| ⑤ AE lock.....P. 77, 201 | ⑲ Aperture value P. 44–50 |
| ⑥ Live view boost.....P. 188 | ⑳ Exposure compensation value.....P. 68 |
| ⑦ Highlight & shadow control.....P. 115 | ㉑ Top: Flash intensity controlP. 105
Bottom: Exposure compensation....P. 68 |
| ⑧ White balance.....P. 94 | ㉒ Card slot settings |
| ⑨ ISO sensitivityP. 75, 91 | Top: Save slot.....P. 237 |
| ⑩ Battery level.....P. 32 | Bottom: Save settingsP. 99 |
| ⑪ Card write indicator.....P. 21, 27 | ㉓ Available recording timeP. 317 |
| ⑫ Wireless LAN connection
statusP. 245, 256 | ㉔ Number of storable still pictures ...P. 316 |
| ⑬ Active Bluetooth® connectionP. 246 | ㉕ Level gauge*2P. 40 |
| ⑭ Active connection to computer (Wi-Fi)
.....P. 256 | ㉖ Active connection to computer (USB)*3
.....P. 274 |
| | ㉗ Recording time (displayed during
recording).....P. 59 |

*1 Displayed in the viewfinder only. [] * Custom Menu [] > [S-OVF] (P. 197)

*2 Displayed when the shutter button is pressed halfway. [] * Custom Menu [] > [Half Way Level] (P. 197)

*3 Displayed only if a computer is currently selected in the [] menu as the sole destination for new pictures (P. 275).

MENU → → → **[Info Settings]**

Choose the information that can be viewed by pressing the **INFO** button in the viewfinder display. Just as you can with the monitor, you can display a histogram or level gauge in the viewfinder by pressing the **INFO** button. This item is used to choose the types of display available. It takes effect when [Style 1] or [Style 2] is selected for [EVF Style].

- This item is for still photography. The option selected for [Info Settings] takes effect in mode (P. 164).

Basic Information	The camera displays icons and the like showing camera settings.
Custom1/ Custom2	In addition to the base display, you can opt to view or hide: []: A histogram superimposed on the display in the viewfinder. [Highlight&Shadow]: Tints applied to over- and under-exposed areas. [Level Gauge]: The level gauge.

- Items marked with checks (✓) appear in the viewfinder display.
- To choose the custom displays available in the viewfinder, highlight [Custom1] or [Custom2] and press on the arrow pad.

Button Hold Options**(Press-and-hold Time)****MENU** → → → **[Press-and-hold Time]**

Choose how long buttons must be pressed to perform resets and other similar functions for various features. For ease of use, button hold times can be set separately for different features.

- This item applies during both still photography and movie recording.

Available Features

- End LV
- Reset LV Frame
- End (movie teleconverter zoom frame display)
- Reset Frame (movie teleconverter zoom frame position)
- Reset
- Reset (flash compensation)
- Reset (highlight and shadow control)
- Reset (color creator)
- Reset
- Call EVF Auto Switch
- End
- End
- Reset
- Switch Lock (touch controls)
- Call BKT Settings
- End Flicker Scan

Correcting Fisheye Distortion (Fisheye Compensation)

MENU → * → [1] → [Fisheye Compensation]

Correct distortion caused by fisheye lenses to give photos the appearance of pictures taken with a wide-angle lens. The amount of correction can be selected from three different levels. You can also opt simultaneously to correct distortion in photos taken under water.

- This option is available in **P**, **A**, **S**, **M**, and **B** modes.
- This option is only available with compatible fisheye lenses.

As of November 2019, it could be used with the M.ZUIKO DIGITAL ED 8mm f1.8 Fisheye PRO.

Angle	When fisheye correction is performed, the picture is cropped to eliminate blacked-out areas. Choose from three different crops.
 Correction	Choose whether to correct distortion in photos taken under water in addition to the correction performed using [Angle].

- 1 Highlight [Fisheye Compensation] in * Custom Menu [1] and press the (OK) button.



- 2 Highlight [On] using the Δ ▽ buttons and press the ▷ button.
 - [Angle] and [ Correction] will be displayed.



- 3 Highlight an item using the Δ ▽ buttons and press the ▷ button.
 - Highlight an option using the Δ ▽ buttons and press the (OK) button.
 - If you are not taking photos under water, choose [Off] for [ Correction].
 - [Fisheye Compensation] options will be displayed.



4 Press the **OK** button repeatedly to exit to the **Custom Menu 01**.

- After confirming that [On] is selected for [Fisheye Compensation], press the **MENU** button to exit the menus.
- When fisheye compensation is enabled, a **FF** icon will be displayed together with the selected crop.

Fisheye compensation

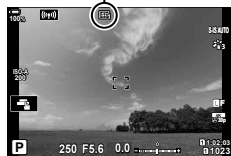

5 Take pictures.

- Pictures taken with [RAW] selected for image quality are recorded in RAW + JPEG format. Fisheye compensation is not applied to the RAW image.
- Focus peaking is not available in the fisheye compensation display.
- AF-target selection is restricted to single- and small-target modes.
- The following cannot be used:
 - live composite photography, burst photography, bracketing, HDR, multiple exposure, the live ND filter, keystone compensation, the digital teleconverter, movie recording, [C-AF], [C-AF **MF**], [C-AF+TR], and [C-AF+TR **MF**] AF modes, [e-Portrait] and art filter picture modes, the custom self-timer, and High Res Shot.



- [Fisheye Compensation] can be assigned to a button. You then need only press the button to enable fisheye correction. **☞** "Assigning functions to buttons (Button Function)" (P. 116)

A number of tasks can be accomplished by connecting the camera to an external device such as a computer or smartphone. Choose a connection type and software according to your goals.

Precautions for Using Wi-Fi and Bluetooth®

Disable wireless LAN and **Bluetooth®** in countries, regions, or locations in which their use is prohibited.

The camera is equipped with wireless LAN and **Bluetooth®**. Use of these features in countries outside the region of purchase may violate local wireless regulations.

Some countries and regions may prohibit the acquisition of location data without prior governmental permission. In some Olympus sales areas, the camera may consequently ship with location data displays disabled.

Each country and region has its own laws and regulations. Check them before traveling and observe them while abroad. Olympus assumes no liability for any failure on the part of the user to observe local laws and regulations.

Disable Wi-Fi on airplanes and in other locations where their use is prohibited.

 "Disabling Wi-Fi/**Bluetooth®**" (P. 255, 271)

- Wireless transmissions are vulnerable to interception by third parties. Use wireless features with this in mind.
- The wireless transceiver is located in the camera grip. Keep it as far away as practicable from metal objects.
- When transporting the camera in a bag or other container, be aware that the contents of the container or the materials of which it is constructed may interfere with wireless transmissions, which can prevent the camera connecting to a smartphone.
- Wi-Fi connections increase the drain on the batteries. The connection may be lost during use if the batteries are low.
- Devices such as microwave ovens and cordless phones that generate radio-frequency emissions, magnetic fields, or static electricity may slow or otherwise interfere with wireless data transmission.
- Some wireless LAN features are unavailable when the memory card write-protect switch is in the "LOCK" position.

Connecting to Smartphones via Wi-Fi

Connect the camera and smartphone using a direct Wi-Fi link.

Installing Apps

To connect to the camera from your smartphone via Wi-Fi, use “OLYMPUS Image Share” (OI.Share).

What You Can Do Using OLYMPUS Image Share

- Download pictures from the camera (P. 251)
- Take pictures remotely (P. 253)
- Save camera settings to your smartphone
- Update camera firmware

OLYMPUS Image Share is available for download from:

<http://app.olympus-imaging.com/oishare/>

In addition to OI.Share, Olympus offers the following apps for viewing sensor logs and retouching pictures:

- **OLYMPUS Image Track (OI.Track)**

Use “OLYMPUS Image Track” (OI.Track) to view and manage field sensor logs recorded with the camera (P. 254).

OLYMPUS Image Track is available for download from:

<http://app.olympus-imaging.com/oitrack/>

- **OLYMPUS Image Palette (OI.Palette)**

Use “OLYMPUS Image Palette” (OI.Palette) to retouch pictures downloaded to the smartphone. Supported are such features as art filters, the Color Creator, and cropping pictures.

OLYMPUS Image Palette is available for download from:

<http://app.olympus-imaging.com/oipalette/>

Connecting to Smartphones (Wi-Fi/Bluetooth Settings)

Adjust camera settings for connection to a smartphone. OI.Share (P. 245) is required. Changes made using OI.Share apply to both Wi-Fi and **Bluetooth**[®]. Install the app on the smartphone before proceeding.

■ Readyng the Camera (Availability)

Enable Wi-Fi and **Bluetooth**[®] on the camera. Note that this is not necessary at default settings, as Wi-Fi is enabled by default. The camera displays a  icon when Wi-Fi is enabled.

- 1 Press the **MENU** button to display the menus.
- 2 Highlight [Wi-Fi/Bluetooth Settings] in the \updownarrow setup menu and press \triangleright on the arrow pad.

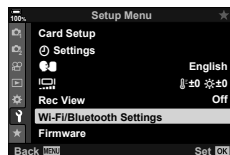

- 3 Highlight [Availability] using the Δ ∇ buttons and press the \triangleright button.



- 4 Highlight [On] using the Δ ∇ buttons and press the OK button.
 - [Wi-Fi/Bluetooth Settings] options will be displayed.



- 5 Press the **MENU** button repeatedly to exit the menus.
 - A  icon will be displayed.



■ Pairing the Camera and Smartphone

Follow the steps below when connecting the devices for the first time.

- Adjust pairing settings using OI.Share, not the settings app that is part of the smartphone operating system.

- 1 Launch the copy of the dedicated OI.Share app previously installed on your smartphone.

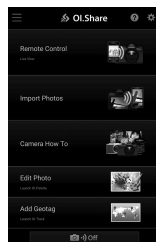

- 2 Press the **MENU** button on the camera to display the camera menus.

- 3 Highlight [(Wi-Fi) Wi-Fi Connect] in the [▶] playback menu and press [▶] on the arrow pad.

- [(Wi-Fi) Wi-Fi Connect] options will be displayed.
- This item is only available when [On] is selected for [Wi-Fi/Bluetooth Settings] > [Availability] in the camera ⚙ setup menu.

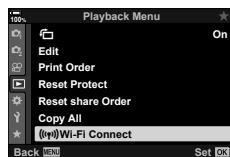

- 4 Highlight [Device Connection] using the [Δ] [▽] buttons and press the [OK] button.

- A pairing guide will be displayed in the camera monitor.



- 5 Press the [OK] button after reading each page of instructions.

- Stop when you reach the following display.

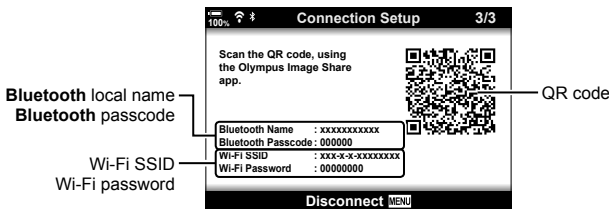

- The display lists the **Bluetooth** local name and passcode, the Wi-Fi SSID and password, and a QR code.

- 6 Tap the camera icon at the bottom of the OI.Share display.
- An [Easy Setup] tab will be displayed.

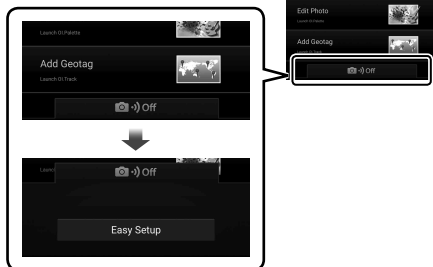

- 7 Following the instructions displayed by OI.Share, scan the QR code to proceed with pairing.
- OI.Share will display a message when settings are complete.
 - If the smartphone is unable to read the QR code, you will need to configure the device manually following the instructions displayed by OI.Share.
 - Bluetooth®:** In the OI.Share **Bluetooth®** settings dialog, select the local name displayed in the camera monitor and enter the passcode.
 - Wi-Fi:** Display Wi-Fi settings in the smartphone settings app and enter the SSID and password displayed by the camera. For information on the settings app, see the documentation for your smartphone.
 - 📶 will be displayed when pairing is complete.



- 8 Once the devices are paired, tap [Import Photos] in the smartphone OI.Share display to view the pictures on the camera memory card.
- To end the connection, press the camera **MENU** button or tap [Disconnect] in the monitor.
 - You can also end the connection by turning the camera off from inside the OI.Share display.



- You can change the connection password generated by the camera (P. 272).

Connecting When the Camera Is Off (Power-off Standby)

The camera can be configured not to end the connection to the smartphone when turned off. The smartphone can then access the camera and automatically download pictures while the camera is off.

- Before proceeding, confirm that:
 - [On] is selected for [Wi-Fi/Bluetooth Settings] > [Availability] (P. 246),
 - the camera and smartphone are paired (P. 247), and
 - a memory card is inserted
- The camera performs network-related processing while powering down with [On] (enabled) selected for [Power-off Standby]. It may therefore require additional time to power on immediately after having been turned off.

Select	When turning the camera off via the ON/OFF lever, you will be prompted to choose whether the wireless connection to the smartphone remains active while the camera is off.
Off	Turning the camera off ends the wireless connection to the smartphone.
On	The wireless connection to the smartphone remains active after the camera is turned off. The smartphone can be used to download pictures from the camera or view the pictures on the camera memory card.

- 1 Press the **MENU** button to display the menus.
- 2 Highlight [Wi-Fi/Bluetooth Settings] in the \updownarrow setup menu and press \triangleright on the arrow pad.
- 3 Highlight [Power-off Standby] using the $\Delta \nabla$ buttons and press the \triangleright button.
- 4 Highlight an option using the $\Delta \nabla$ buttons and press the \odot button.
- 5 Press the **MENU** button repeatedly to exit the menus.

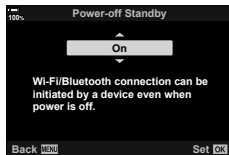
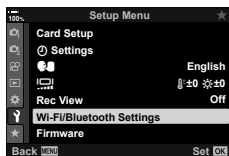

[Select]

If you select [Select] for [Power-off Standby], a confirmation dialog will be displayed the next time the camera is turned off. Highlight an option using Δ ∇ on the arrow pad and press the \odot button.

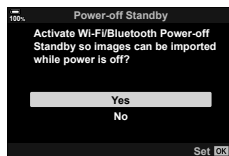

Yes	The camera will turn off, leaving the wireless connection to the smartphone active.
No	The camera will end the connection to the smartphone before turning off.

- If no operations are performed about a minute after the confirmation dialog is displayed, the camera will end the wireless connection to the smartphone and turn off automatically.
- The connection will end automatically under the conditions listed below. The connection will be re-enabled when next you turn the camera on.
 - 12 hours pass with no data being exchanged with the smartphone.
 - The memory card is removed and reinserted.
 - The batteries are replaced.

Copying Pictures to Smartphones

Pictures on the camera memory card can be downloaded to a smartphone using either of the following methods:

- Use the smartphone to select pictures for download.
- Automatically download previously-selected pictures while the camera is off.
 - ▶ “Selecting Pictures for Sharing (Share Order)” (P. 132)

These methods are described below.

■ Downloading Pictures Selected with OI.Share

Use the smartphone to view the pictures on the camera and select pictures for download.

- 1 Connect to the camera using OI.Share (P. 247).
- 2 Tap [Import Photos] in OI.Share.
 - OI.Share will list the images on the camera.
 - The memory card can be selected using OI.Share.



- 3 Select pictures and tap the save button.



■ Auto Download

Pictures previously marked for sharing on the camera can be downloaded automatically when the camera is off.

1 Mark pictures for sharing.

- Display pictures and mark them for sharing. See “Selecting Pictures for Sharing (Share Order)” (P. 132) for more information.

2 Choose the operation performed when the camera is off.

- Choose an option for [Power-off Standby]. See “Connecting When the Camera Is Off (Power-off Standby)” (P. 249) for more information.
- **MENU** button → **↑** (setup menu) → [Wi-Fi/Bluetooth Settings] → [Power-off Standby] → Highlight [On] or [Select] and press the **OK** button

3 Turn the camera off.

- The selected photos and movies will be uploaded to the smartphone automatically. If you are using an iOS device, launch OI.Share on the smartphone before turning the camera off.
- If [Select] is chosen for [Power-off Standby], a confirmation dialog will be displayed (P. 250). Highlight [Yes] and press the **OK** button.
- Up to 200 pictures on each slot can be marked for sharing at a time.
- iOS devices will not connect to the camera automatically via a router or other wireless access point. Use OI.Share to download pictures.
- Some smartphones may end download on entering sleep mode. Configure the smartphone to not enter sleep mode.

Remote Photography Using a Smartphone

Use OI.Share to control the camera remotely and take pictures from a smartphone.

- Not all shooting options are available.

1 Connect to the camera using OI.Share (P. 247).

2 Tap [Remote Control] in OI.Share.

- Remote control options will be displayed.

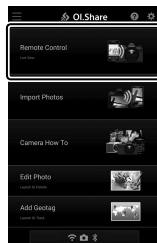

3 Tap the shutter button to take pictures.





- The pictures will be saved to the memory card.



Shutter button

Adding position information to images

You can add GPS tags to images that were taken while the GPS log was saving by transferring the GPS log saved on the smartphone to the camera.

- 1** Before taking pictures with the camera, launch OI.Track on the smartphone to begin saving the GPS log.
 - Before starting a GPS track log, you will need to connect once via OI.Track and synchronize the clock.
 - You can use the phone or other apps while the GPS log is saving. Do not terminate OI.Track.
 - 2** Once you have finished taking pictures with the camera, end tracking in OI.Share.
 - 3** Tap the  icon in the camera monitor to connect to the smartphone.
 - You can also connect by selecting [Wi-Fi Connect] in the  playback menu (P. 247).
 - 4** Upload the GPS log to the camera using OI.Track.
 - The GPS log will be used to add location data to any pictures taken after you launched OI.Track in Step 1.
 -  is displayed on images to which position information has been added.
- Addition of location information can only be used with smartphones that have a GPS function.
 - Position information cannot be added to movies.

Ending the Connection

End the connection to the smartphone. The camera uses Wi-Fi and **Bluetooth®** when connecting to smartphones. The use of these features may be prohibited in some countries or regions, in which case they should be disabled.

■ Ending the Current Connection

- 1 Use the [Power Off] slider in the OI.Share or OI.Track settings dialog.
 - Alternatively, you can press the camera **MENU** button and tap [Disconnect] in the monitor.



MENU button



Disconnect



- 2 Select [Off] for [Power-off Standby] to disable the “auto upload while off” feature.
 - **MENU** button → \updownarrow setup menu → [Wi-Fi/Bluetooth Settings] → [Power-off Standby] → [Off]

■ Disabling Wi-Fi/Bluetooth®

- 1 Press the **MENU** button to display the menus.
- 2 Highlight [Wi-Fi/Bluetooth Settings] in the \updownarrow setup menu and press \triangleright on the arrow pad.
- 3 Highlight [Availability] using the $\Delta \nabla$ buttons and press the \triangleright button.
- 4 Highlight [Off] using the $\Delta \nabla$ buttons and press the \odot button.

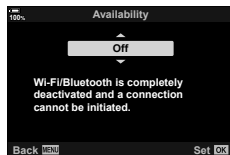
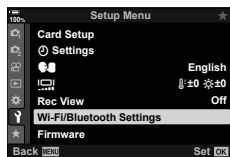

Connecting to Computers via Wi-Fi

Connect the camera and computer via Wi-Fi. Using Wi-Fi, the camera can connect via a router to a computer on a household network or the like.

Installing Software

Use “OLYMPUS Capture” to connect the camera and computer via Wi-Fi.

OLYMPUS Capture

Use “OLYMPUS Capture” to automatically download and view pictures taken with a camera connected via Wi-Fi to the same network as the computer. To learn more or to download the software, visit the website below. When downloading the software, be prepared to provide the camera serial number.

<http://app.olympus-imaging.com/olympuscapture/>

Follow the on-screen instructions to install the software. System requirements and installation instructions are available at the website above.

Readying the Computer (Windows)

If Windows is unable to detect a camera connected via a router or access point, follow the steps below to register the device manually.

■ Windows 8/Windows 10

- 1 Click the [Start] button on the computer desktop to display the Start menu.
- 2 Click  (Settings) to display [Windows Settings] options.



- 3 Click [Devices] to display options for [Bluetooth & other devices].

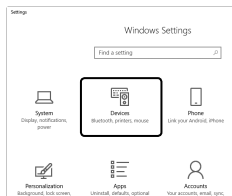

- 4 Click [Add Bluetooth or other devices].
- 5 Click [+ Everything else].
 - An [Add a device] window will open and [E-M1 Mark III] will be displayed after a short pause.
- 6 Click [E-M1 Mark III].
 - When a message is displayed stating the preparation is complete, click [Done].

■ Windows 7

- 1 Launch Windows Explorer and select "Network".
 - [E-M1 Mark III] will be displayed in Windows Explorer.
- 2 Right-click [E-M1 Mark III] and select [Install].
 - A message will be displayed when device registration is complete.
 - Check that the device is registered in the Device Manager.

Pairing the Computer with the Camera

(New Link)

The camera and computer must be paired in order to connect. Up to four computers can be paired with the camera at a time. To pair a computer with the camera, connect it via USB. Pairing need only be performed once per computer.

- 1 After confirming that the camera is off, connect it to the computer using the USB cable.

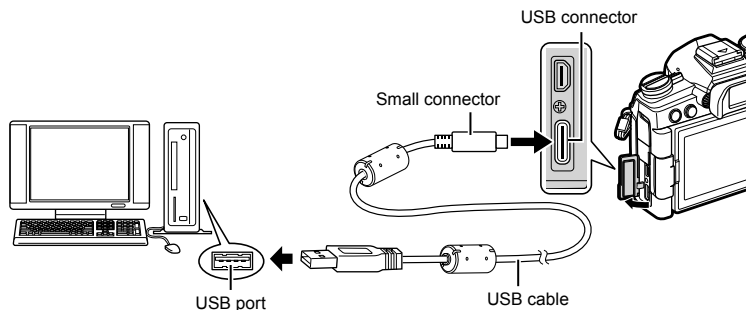

- The locations of USB ports vary from computer to computer. See the documentation provided with the computer for information on USB ports.

- 2 Turn the camera on.

- The camera will display a message prompting you to identify the device to which the USB cable is connected.
- If the message is not displayed, select [Auto] for [USB Mode] (P. 190) in **Custom Menu D4**.
- If the batteries are very low, the camera will not display a message when connecting to a computer. Be sure the batteries are charged.

- 3 Highlight [📷] using Δ ∇ on the arrow pad and press the **OK** button.

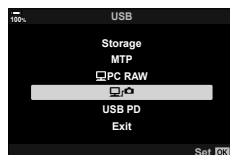

- 4 Launch the copy of "OLYMPUS Capture" installed on the computer.

- After starting up, "OLYMPUS Capture" will prompt you to choose the connection type.



5 Click the [+] to the right of [Create new link].

- If nothing happens, reconnect the camera.



- Enter the name that will be used on the camera to identify the computer. The default is the computer's "Computer Name".
- The name used on the camera can be up to 15 characters long.

6 Click [Settings] in "OLYMPUS Capture".

- When a message is displayed stating that pairing is complete, disconnect the camera as instructed.

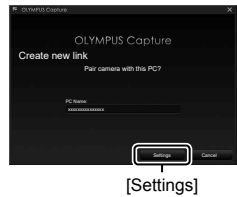
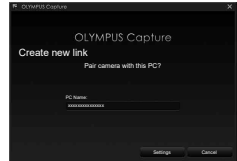



- Repeat the above steps to pair the camera with each additional computer.
- The pairing information stored on the camera can be viewed and deleted using "OLYMPUS Capture".

Adjust settings for connection to the network to which the paired computer belongs.

Before the camera can connect to the computer via Wi-Fi, it must be configured for connection to the network via the Wi-Fi router or access point. Multiple network profiles can be stored on the camera and recalled as desired. (((Wi-Fi Connect))) settings can be adjusted via the following methods:

Connect by WPS	Configure the camera for automatic connection (P. 262). To connect using a WPS router or access point, simply press the device's WPS button. [PBC Method]: Connect using only the router WPS button. The camera connects automatically when the button is pressed. [PIN Method]: The camera connects in PIN mode. Enter the camera PIN on the router to connect.
Connect from Access Point List	Choose the network from a list (P. 266). The camera will search for available networks; to connect, select a network from the list and enter the network password.
Connect manually	Adjust connection settings manually (P. 264). To connect, enter the network name (SSID) and other settings.

- WPS connections require a WPS-compatible router or access point.
- Connecting via WPS in PIN mode requires that the router itself be connected to an administrator computer from which the PIN can be entered.
- Manual connection requires that you have information on the network to which you are connecting.
- The camera can connect via routers or access points of the following types:
 - Standard: IEEE802.11a/b/g/n/ac
 - Band: 2.4 GHz or 5 GHz
 - Security: WPA2
- The camera can store settings for up to eight networks. The camera will automatically connect to networks to which it has previously connected.
- Each new connection after the eighth overwrites settings for the connection that has been left unused for the longest period of time.
- Adding a network profile for an access point with the same MAC address as existing profile overwrites the settings for the existing profile.
- For information on using routers or access points, see the documentation provided with the device.
- Network profiles are not reset when you select [Full] for [Reset / Custom Modes] (P. 141) > [Reset] in  Shooting Menu 1. To reset network settings, use [Wi-Fi/Bluetooth Settings] (P. 273) > [Reset Settings] in the  setup menu.

■ Enabling Camera Wi-Fi (Wi-Fi/Bluetooth Settings)

Before connecting to a network via Wi-Fi, you will need to enable Wi-Fi on the camera. Note that this is not necessary at default settings, as Wi-Fi is enabled by default. Proceed to page 262.

- 1 Press the **MENU** button to display the menus.
- 2 Highlight [Wi-Fi/Bluetooth Settings] in the \updownarrow setup menu and press \triangleright on the arrow pad.
- 3 Highlight [Availability] using the $\Delta \nabla$ buttons and press the \triangleright button.
- 4 Highlight [On] using the $\Delta \nabla$ buttons and press the \odot button.
 - [Wi-Fi/Bluetooth Settings] options will be displayed.
- 5 Press the **MENU** button repeatedly to exit the menus.

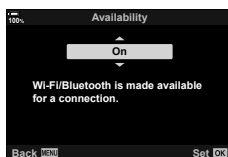
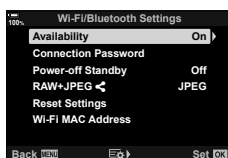
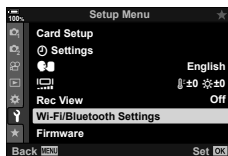

■ Connecting via WPS (Connect by WPS)

Connect using the WPS feature on the router or access point.

1 Press the **MENU** button on the camera to display the camera menus.

2 Highlight [(Wi-Fi)] Wi-Fi Connect] in the [▶] playback menu and press [▶] on the arrow pad.

- [(Wi-Fi)] Wi-Fi Connect] options will be displayed.
- This item is only available when [On] is selected for [Wi-Fi/Bluetooth Settings] > [Availability] in the camera [⏏] setup menu.

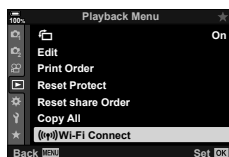

3 Highlight [Access Point Connection] using the [Δ] [▽] buttons and press the [OK] button.

- [Access Point Connection] options will be displayed.



4 Highlight [Connect by WPS] using the [Δ] [▽] buttons and press the [OK] button.



5 Highlight an option using the [Δ] [▽] buttons and press the [OK] button.

- If you selected [PBC Method], press the WPS button on the router or access point.
- Press the camera [OK] button to start the connection.
- Some time may be required for connection after the button is pressed.
- If you selected [PIN Method], the camera will display a PIN; enter it on the router or access point. Press the camera [OK] button when the router is ready to connect.

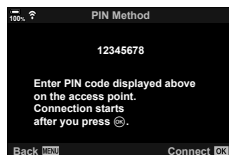

6 If the camera is able to connect, the network will be displayed with a check (✓) next to the network name.

- If the camera has been paired with more than one computer, you will be prompted to choose a computer before the network is displayed. Highlight the desired computer using the Δ ∇ buttons and press the \odot button.
- The camera can be used only with the selected computer. To select a different computer, you must first terminate the current connection.
- If the connection fails, the camera will display a message to that effect, followed by the options shown in Step 5. Repeat Steps 5–6.

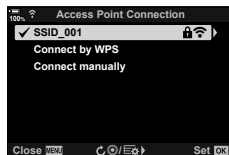

7 Press the \odot button to exit to the shooting display.

- The camera will return to the standard shooting display. A  icon will be displayed in the monitor.



■ Connecting Manually (Manual Connections)

Adjust network settings manually. You will need to provide:

SSID	The network name (SSID).
Authentication	The type of security used on the network.
Password	The password for connection to a secured network.
IP Address Assign	Choose whether the camera IP address is assigned automatically by the network DHCP server.
IP Address	These fields are required when the IP address is assigned manually. The settings used vary with the network.
Subnet Mask	
Default Gateway	
DNS	

- 1 Press the **MENU** button on the camera to display the camera menus.
- 2 Highlight [(Wi-Fi)] Wi-Fi Connect] in the [▶] playback menu and press [▶] on the arrow pad.
 - [(Wi-Fi)] Wi-Fi Connect] options will be displayed.
 - This item is only available when [On] is selected for [Wi-Fi/Bluetooth Settings] > [Availability] in the camera [↵] setup menu.
- 3 Highlight [Access Point Connection] using the [Δ] [▽] buttons and press the [OK] button.
 - [Access Point Connection] options will be displayed.
- 4 Highlight [Connect manually] using the [Δ] [▽] buttons and press the [OK] button.



- 5** Highlight items using the Δ ∇ buttons and press the $\text{\textcircled{OK}}$ button.
- Options for the selected item will be displayed.

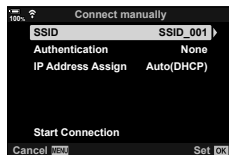

SSID	Enter the network SSID.
Authentication	Select the type of security used on the network. Choose from [None] and [WPA2].
Password	If you selected [WPA2] for [Authentication], enter the network password.
IP Address Assign	Choose from [Auto(DHCP)] and [Manual]. Automatic IP address assignment requires a network with a DHCP server configured to supply IP addresses automatically.
IP Address	
Subnet Mask	
Default Gateway	
DNS	

- 6** Highlight [Start Connection] using the Δ ∇ buttons and press the $\text{\textcircled{OK}}$ button.

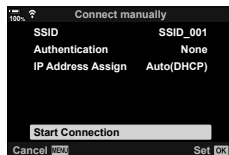

- 7** If the camera is able to connect, the network will be displayed with a check (\checkmark) next to the network name.

- If the camera has been paired with more than one computer, you will be prompted to choose a computer before the network is displayed. Highlight the desired computer using the Δ ∇ buttons and press the $\text{\textcircled{OK}}$ button.
- The camera can be used only with the selected computer. To select a different computer, you must first terminate the current connection.
- If the connection fails, the camera will display a message to that effect, followed by the options shown in Step 6. Repeat Steps 5–6.

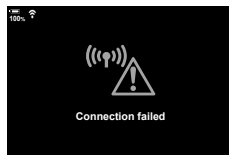
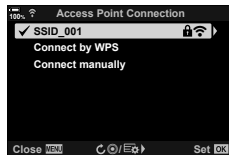

8 Press the **OK** button to exit to the shooting display.

- Standard shooting indicators will be displayed. A  icon will appear in the monitor.



 icon



■ Choosing a Network from a List (Connect from Access Point List)



The camera will search for available networks and display them in a list from which you can choose the network to which you wish to connect.

1 Press the **MENU** button on the camera to display the camera menus.

2 Highlight **[Wi-Fi Connect]** in the  playback menu and press  on the arrow pad.

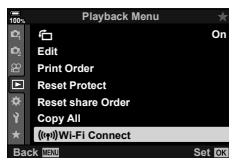

- **[Wi-Fi Connect]** options will be displayed.
- This item is only available when **[On]** is selected for **[Wi-Fi/Bluetooth Settings] > [Availability]** in the camera  setup menu.



3 Highlight **[Access Point Connection]** using the   buttons and press the **OK** button.



- **[Access Point Connection]** options will be displayed.





4 Highlight **[Connect from Access Point List]** using the   buttons and press the **OK** button.





- A list of available networks will be displayed.





5 Highlight the desired network using the   buttons and press the **OK** button.

- If the network is password-protected, you will be prompted to enter a password. Enter the password and press the **OK** button.
- Press the  button to display **[Detail Settings]** for the highlighted network. You can enter an IP address and adjust other settings manually.
- Press the  button to repeat the search and update the network list.



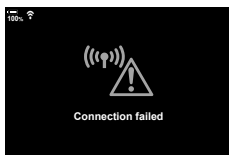





- 6** If the camera is able to connect, the network will be displayed with a check mark (✓) next to the network name.
- Password-protected networks are indicated by a  icon.
 - If the camera has been paired with more than one computer, you will be prompted to choose a computer before the network is displayed. Highlight the desired computer using the   buttons and press the  button.
 - The camera can be used only with the selected computer. To select a different computer, you must first terminate the current connection.
 - If the connection fails, the camera will display a message to that effect, followed by the options shown in Step 5. Repeat Steps 5–6.



- 7** Press the  button to exit to the shooting display.
- Standard shooting indicators will be displayed. A  icon will appear in the monitor.



Connecting to Previously-Selected Networks

- The camera will automatically reconnect to previously-selected networks when you select [Access Point Connection] via the  icon. You will not be required to supply a password.
- If multiple networks are available, the camera will connect first to the most recently-used network.
- Once the camera has connected, it will display a list of available networks with the current network shown by a check mark .
- To connect to a different network, highlight it in the list and press the .
- If the camera has been paired with more than one computer on the network, you will be prompted to choose a computer before the network list is displayed. Highlight the desired computer using the   buttons and press the .

Uploading Pictures as They Are Taken

Take pictures and upload them to a computer on the same network as the camera. Before proceeding, connect the camera and computer as described in “Pairing the Computer with the Camera (New Link)” (P. 258).

1 Launch “OLYMPUS Capture” on destination computer.

- If prompted to choose a connection type, click [Wi-Fi Connection].
- The computer will display the message, [Camera connected] when the camera is detected.



[Wi-Fi Connection]

- The camera will display the message shown at right when a connection is established.

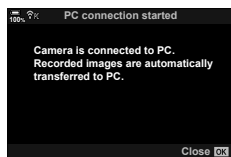

2 Configure “OLYMPUS Capture” to automatically download pictures as they are taken.

- Select the source card slot (1 or 2) and the type of pictures (JPEG photos, RAW photos, or movies) to be downloaded.
- Choose a destination for the downloaded pictures.



The “OLYMPUS Capture” control window

3 Take pictures using camera controls.

- The pictures will be uploaded to the computer after they are saved to the camera memory card.
- A PC (“image upload”) icon will be displayed while upload is in progress.
- The camera will upload only photos and movies recorded while the camera and computer are connected. Any pictures taken before Wi-Fi was enabled on the camera will not be uploaded.

Image upload



- While the camera is connected to a network:
 - Sleep mode is disabled
 - Interval-timer photography is not available
 - Some restrictions apply to the options available during playback
- [PC connection ended] options will be displayed when the camera's connection to the network ends. Upload of any remaining data will resume when the connection is re-established. Note, however, that remaining data will not be uploaded if:
 - The Wi-Fi connection is ended using camera controls
 - The camera is turned off
 - The source memory card is removed
- The upload queue for each card can contain no more than 3000 pictures.
- If "OLYMPUS Capture" displays the message [This application is unable to find a camera in the camera control mode.], check:
 - that the camera has been paired with the computer,
 - that you selected the correct computer when connecting to the network, and
 - that the camera is registered with the computer (Windows only).  "Readying the Computer (Windows)" (P. 257)

Ending the Connection

End the Wi-Fi connection. The use of Wi-Fi may be prohibited in some countries or regions, in which case Wi-Fi should be disabled.

■ Ending the Current Connection

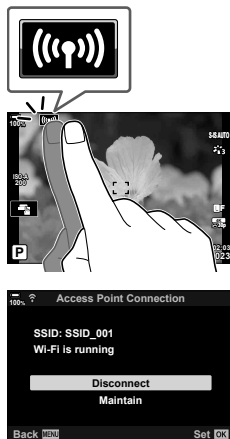

1 Tap  in the camera monitor.



- You will be prompted to confirm whether you wish to disconnect.
- The network SSID is shown in the display.

2 Highlight [Disconnect] using Δ ∇ on the arrow pad and press the \odot button.

- The camera will terminate the connection and exit to the shooting display.
- A confirmation dialog will be displayed if data remain to be uploaded. To terminate the connection, highlight [Yes] and press the \odot button.

3 To reconnect, tap  or select []Wi-Fi Connect] > [Access Point Connection] in the  playback menu and press the \odot button.

- The camera will automatically reconnect to previously-selected networks.
- To connect to a new network, highlight [Maintain] in Step 2 and press the \odot button. Choose from a list of available networks and adjust settings as described in “Choosing a Network from a List (Connect from Access Point List)” (P. 266).
- If you turn the camera off while upload is in progress, you will be prompted to choose whether to power the camera down and terminate the Wi-Fi connection immediately or to power the camera down only after upload is complete.

■ Disabling Wi-Fi/Bluetooth®

- 1 Press the **MENU** button to display the menus.
- 2 Highlight [Wi-Fi/Bluetooth Settings] in the **↓** setup menu and press **▶** on the arrow pad.
 - [Wi-Fi/Bluetooth Settings] options will be displayed.
- 3 Highlight [Availability] using the **△** **▽** buttons and press the **▶** button.
- 4 Highlight [Off] using the **△** **▽** buttons and press the **Ⓞ** button.

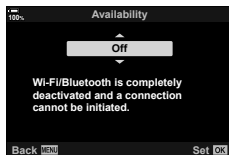
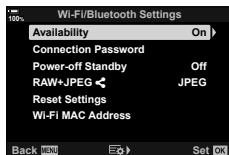
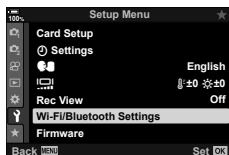

Network Settings

Change the password used for Wi-Fi connections from a smartphone or restore default Wi-Fi settings used for connection to a computer. The latter are not restored when a camera reset is performed and can only be restored as described below.

Changing Passwords (Connection Password)

Generate new passwords for use when connecting to the camera from a smartphone via Wi-Fi or **Bluetooth**®.

- 1 Press the **MENU** button to display the menus.
- 2 Highlight [Wi-Fi/Bluetooth Settings] in the \downarrow setup menu and press \triangleright on the arrow pad.
 - [Wi-Fi/Bluetooth Settings] options will be displayed.

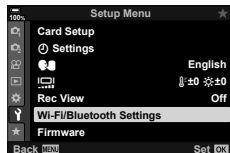

- 3 Highlight [Connection Password] using the Δ ∇ buttons and press the \triangleright button.
 - The current password will be displayed.



- 4 Press the \odot (movie) button.
 - The password changes each time the button is pressed.
 - Both the Wi-Fi and **Bluetooth**® passwords change.
 - Press the \odot button to exit the [Connection Password] display.
- 5 Press the \odot button again to exit the [Wi-Fi/Bluetooth Settings] menu.
 - Press the **MENU** button repeatedly to exit the menus.
 - After changing the password, you will need to update smartphone connection settings (P. 246).

Restoring Default Wi-Fi/Bluetooth® Settings (Reset Settings)

Restore default Wi-Fi and **Bluetooth**® settings. All settings, including those for connection via a router and pairing information for the computers on the network, are reset.

- 1 Press the **MENU** button to display the menus.
- 2 Highlight [Wi-Fi/Bluetooth Settings] in the \uparrow setup menu and press \triangleright on the arrow pad.
 - [Wi-Fi/Bluetooth Settings] options will be displayed.
- 3 Highlight [Reset Settings] using the Δ ∇ buttons and press the \triangleright button.
 - [Reset Settings] options will be displayed.
- 4 Highlight [Yes] using the Δ ∇ buttons and press the OK button.
 - Settings will be reset and the camera will exit to the [Wi-Fi/Bluetooth Settings] display.
 - Both the Wi-Fi and **Bluetooth**® passwords will be reset.
- 5 Press the **MENU** button repeatedly to exit the menus.

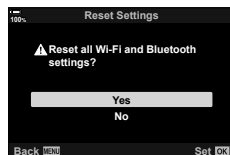
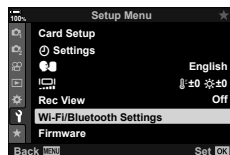

Connecting to Computers via USB

Connect the camera to a computer using the USB cable.

Compatible Computers

Connect the camera to the computer using the supplied USB cable.

- Note that even if the computer is equipped with USB connectors, operation is not guaranteed with:
USB expansion ports, computers not running the operating system with which they shipped, or homemade computers.
- The camera can be connected to computers that meet the following system requirements.
Windows: Windows 7, Windows 8, Windows 8.1, Windows 10
Mac: OS X versions 10.9–10.11, macOS versions v10.12–v10.14

Installing Software

Install the following software to access the camera while it is connected directly to the computer via USB.

OLYMPUS Capture

Use “OLYMPUS Capture” to automatically download and view pictures as they are taken or control the camera remotely. To learn more or to download the software, visit the website below. When downloading the software, be prepared to provide the camera serial number.

<http://app.olympus-imaging.com/olympuscapture/>

Follow the on-screen instructions to install the software. System requirements and installation instructions are available at the website above.

Olympus Workspace

This computer application is used to download, view, and manage photos and movies recorded with the camera. When editing RAW data in the Olympus Workspace (Ver. 1.1 or later), high-speed processing using the camera engine has been enabled. It can also be used to update the camera firmware. The software can be downloaded from the website below. Be prepared to provide the camera serial number when downloading the software.

<https://support.olympus-imaging.com/owdownload/>

Follow the on-screen instructions to install the software. System requirements and installation instructions are available at the website above.

Uploading Pictures as They Are Taken



Connect the camera to a computer via USB to upload pictures as they are taken. You can take pictures using the controls on the camera body or while controlling the camera remotely from the computer.

- 1 After confirming that the camera is off, connect it to the computer using the USB cable.

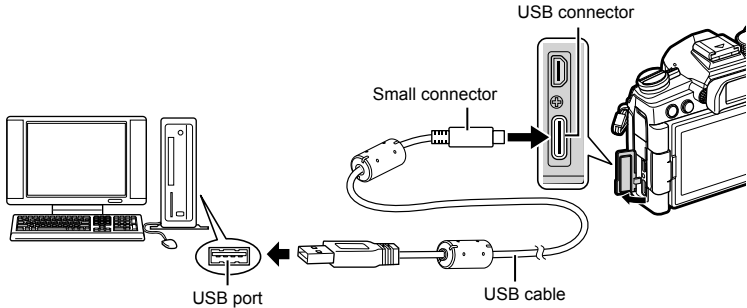

- The locations of USB ports vary from computer to computer. See the documentation provided with the computer for information on USB ports.

- 2 Turn the camera on.

- The camera will display a message prompting you to identify the device to which the USB cable is connected.
- If the message is not displayed, select [Auto] for [USB Mode] (P. 190) in **Custom Menu D4**.
- If the batteries are very low, the camera will not display a message when connecting to a computer. Be sure the batteries are charged.

- 3 Highlight  using Δ ∇ on the arrow pad and press the **OK** button.

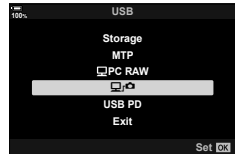

- 4 Launch the copy of “OLYMPUS Capture” installed on the computer.

- When prompted to choose the connection type, click [USB Connection].





[USB Connection]

- 5 Configure “OLYMPUS Capture” for download.
 - Choose a destination for the downloaded pictures.
- 6 Take pictures using camera or computer controls.
 - The pictures will be downloaded to the computer according to the options chosen.
 - The computer cannot be used to change the camera shooting mode.
 - The computer cannot be used to delete pictures from the memory cards inserted in the camera.
 - The camera display frame rate may drop if the view through the camera lens is displayed simultaneously both on the computer and in the camera monitor.
 - See online help for more information on using the software.
 - The connection to the computer will end if you:
 - exit “OLYMPUS Capture”,
 - insert or remove memory cards, or
 - turn the camera off.

Connecting the Camera for High-Speed RAW Processing

( PC RAW)

- 1 After confirming that the camera is off, connect it to the computer using the USB cable.
- 2 Turn the camera on.
 - The camera will display a message prompting you to identify the device to which the USB cable is connected.
 - If the message is not displayed, select [Auto] for [USB Mode] (P. 190) in  Custom Menu **D4**.
 - If the batteries are very low, the camera will not display a message when connecting to a computer. Be sure the batteries are charged.
- 3 Highlight [ PC RAW] using Δ ∇ on the arrow pad and press the  button.

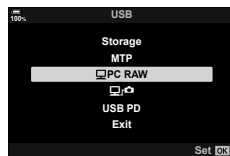

- 4 Launch the copy of “Olympus Workspace” installed on the computer.
 - Click the [USB RAW Data Edit] icon.
- 5 Choose the location containing the pictures to be processed.
 - You can choose either a memory card inserted in the connected camera, or a folder on the computer.
 - Only RAW pictures in the chosen location taken with the connected camera or another camera of the same model can be selected.
 - After choosing the source, click [OK].

6 Process RAW images.

- Adjustments can be made to the shooting settings available on the camera and RAW pictures processed accordingly.
- The processed copies will be saved in JPEG format.
- Enabling USB RAW data editing cancels any changes previously made in the edit window.
- USB RAW data editing is not available when two or more cameras are connected.

Copying Pictures to the Computer (Storage/MTP)

When connected to a computer, the camera can function as external storage in much same way as a hard drive or other external storage device. Data can be copied from the camera to the computer.

- 1 After confirming that the camera is off, connect it to the computer using the USB cable.
- 2 Turn the camera on.
 - The camera will display a message prompting you to identify the device to which the USB cable is connected.
 - If the message is not displayed, select [Auto] for [USB Mode] (P. 190) in **Custom Menu D4**.
 - If the batteries are very low, the camera will not display a message when connecting to a computer. Be sure the batteries are charged.
- 3 Highlight [Storage] or [MTP] using Δ ∇ on the arrow pad and press the **OK** button.

[Storage]: The camera functions as a card reader.

[MTP]: The camera functions as a portable device.

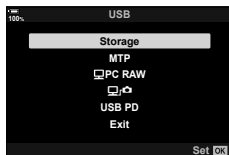

- 4 The camera will connect to the computer as new storage device.

- Data transfer is not guaranteed in the following environments, even if your computer is equipped with a USB port.

Computers with a USB port added by means of an extension card, etc., computers without a factory-installed OS, or home-built computers

- Camera functions cannot be used while the camera is connected to the computer.
- If the computer fails to detect the camera, disconnect and reconnect the USB cable.

Powering the Camera via USB (USB Power Delivery)

Mobile batteries or USB AC adapters conforming to the USB Power Delivery (USB PD) standard can be used to power the camera. The devices must:

Standard: Conform to the USB Power Delivery (USB PD) standard

Output: Be rated for an output of 9 V 3 A, 15 V 2 A, or 15 V 3 A

- This feature cannot be used at battery levels of 10% or less.
- The camera cannot draw power via USB while an optional HLD-9 power battery holder is attached (P. 24).

- 1 After confirming that the camera is off, use the USB cable to connect it to the device.

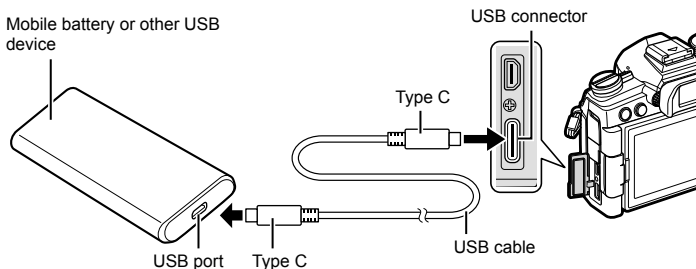

- The supplied USB cable (CB-USB11) cannot be used for USB Power Delivery (USB PD).
- The method used for connection varies from device to device. See the documentation provided with the device for details.
- You may be unable to use USB Power Delivery (USB PD) with some USB devices. See the manual supplied with the USB device.

- 2 Turn the camera on.

- The camera will display a message prompting you to identify the device to which the USB cable is connected.
- If the message is not displayed, select [Auto] for [USB Mode] (P. 190) in **Custom Menu D4**.
- If the batteries are very low, the display will remain blank when the camera is connected to the USB device. Be sure the batteries are charged.

- 3 Highlight [USB PD] using Δ ∇ on the arrow pad and press the **OK** button.

- The camera will draw power from the connected USB device.

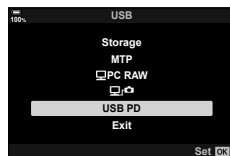

Connecting to TVs or External Displays via HDMI

Pictures can be displayed on televisions connected to the camera via HDMI. Use the television to display pictures to an audience. The TV remote can be used to control the display while the television is connected to the camera. No app or other software is required.



You can also film movies while the camera is connected to an external monitor or video recorder via HDMI.

- HDMI cables are available from third-party suppliers. Use an HDMI-certified cable.

Viewing Pictures on a TV

(HDMI)

Photos and movies can be viewed on a high-definition TV connected directly to the camera by means of an HDMI cable. A remote control can be used to operate the display while it is connected to the camera.

■ HDMI Output

Choose the signal output to the HDMI device. You can adjust movie frame size and frame rate to match TV specifications and the video standards supported in your country or region. Match output settings to the input settings on the TV.

Output Size	The format for the video signal output via the HDMI connector can be chosen from the options below. <ul style="list-style-type: none">• [C4K]: 4K Digital Cinema (4096 × 2160)• [4K]: 4K (3840 × 2160) priority• [1080p]: Full High Definition (1080p) priority• [720p]: High Definition (720p) priority• [480p/576p]: 480p/576p
HDMI Control	When the camera is in playback mode, it can be operated using the television remote control (P. 282). Choose from [Off] and [On]. When [On] is selected, the camera can be used for playback only.
Output Frame Rate	Choose a frame rate for the signal output via the HDMI connector according to whether the television supports NTSC (60p) or PAL (50p).

- [HDMI Control] and [Output Frame Rate] settings cannot be changed while the camera is connected to another device via HDMI.
- Audio can be output only on devices that support the audio format selected with the camera.
- The options available via [HDMI Control] vary with the device connected. See the device manual for details.

- 1 Press the **MENU** button to display the menus.
- 2 Display **Custom Menu D4 (Disp/■)/PC**.

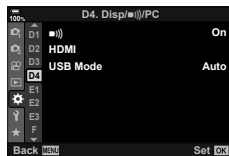

- 3 Highlight [HDMI] using **△ ▽** on the arrow pad and press the **▶** button.

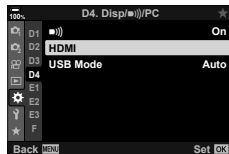

- 4 Highlight an item using the Δ ∇ buttons and press the \triangleright button.

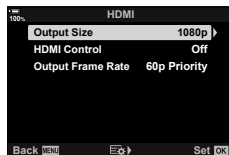

- 5 Highlight the desired option using the Δ ∇ buttons and press the OK button.

- Repeat Steps 4 and 5 as required.

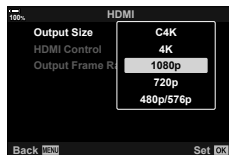

- 6 Press the **MENU** button repeatedly to exit the menus.

■ Connecting the Camera to a TV

Connect the camera using an HDMI cable.

- 1 After confirming that the camera is off, connect it to the TV using an HDMI cable.

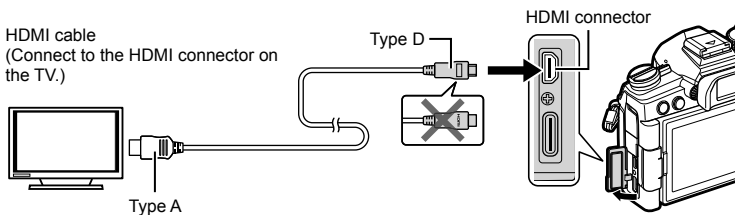

- 2 Switch the TV to HDMI input and turn the camera on.

- The TV will show the contents of the camera monitor. Press the ▶ button to view pictures.
- If [On] is selected for [HDMI Control] (P. 282), the camera monitor will turn off when an HDMI cable is connected.
- For information on switching to HDMI input, see the manual provided with the TV.
- Depending on TV settings, the image may be cropped and some indicators may not be visible.
- HDMI cannot be used while the camera is connected to a computer via USB.
- If [Record Mode] is selected for [HDMI Output] (P. 164) > [Output Mode] in the video menu, the signal will be output at the current movie frame size. No image will be displayed if the TV does not support the selected frame size.
- If [4K] or [C4K] is selected, 1080p priority format will be used during still photography.

When connected to a TV via an HDMI cable, the camera can be operated using the television remote control.

- The television must support HDMI control. See the television manual for more information.

On	The television remote control can be used to operate the camera in playback mode. The camera can be used for playback only.
Off	The television remote control cannot be used to operate the camera. Indicators appear only in the TV display.

- 1 Press the **MENU** button to display the menus.
- 2 Highlight [HDMI] in **Custom Menu D4 (Disp/■)/PC** and press **▶** on the arrow pad.

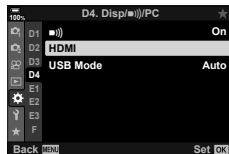

- 3 Highlight [HDMI Control] using the **▲▼** buttons and press the **▶** button.

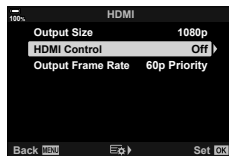

- 4 Highlight [On] using the **▲▼** buttons and press the **⊙** button.

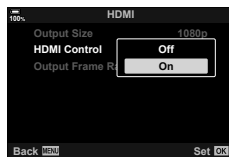

- 5 Press the **MENU** button repeatedly to exit the menus.
 - 6 Connect the camera and TV via HDMI.
 - Play pictures back using the TV remote. Follow the guide displayed on the TV screen.
 - In single-frame playback, use the "red" button to choose the information displayed and the "green" button to switch to the index display.
- Some functions may be unavailable on some televisions.
 - The camera monitor turns off while the TV is used for playback.

Battery and charger

- The camera uses a single Olympus lithium-ion battery. Never use any battery other than genuine OLYMPUS batteries.
- The camera's power consumption varies widely with usage and other conditions.
- As the following consume a lot of power even without shooting, the battery will be drained quickly.
 - Performing auto focus repeatedly by pressing the shutter button halfway in shooting mode.
 - Displaying images on the monitor for a prolonged period.
 - When connected to a computer.
 - Leaving wireless LAN/**Bluetooth**® enabled.
- When using a drained battery, the camera may turn off without the low battery warning being displayed.
- The battery will not be fully charged at the time of purchase. Charge the battery using the provided charger before use.
- Remove the batteries before putting the camera into storage for periods of a month or more. Leaving the batteries in the camera for extended periods shortens their lives, potentially rendering them unusable.
- The normal charging time using the supplied charger is approximately 2 hours (estimated).
- Do not attempt to use chargers not specifically designated for use with the supplied battery, or to use batteries not specifically designated for use with the supplied charger.
- There is a risk of explosion if the battery is replaced with the incorrect battery type.
- Dispose of the used battery following the instructions "CAUTION" (P. 323) in the instruction manual.

Using your charger abroad

- The charger can be used in most home electrical sources within the range of 100V to 240V AC (50/60 Hz) around the world. However, depending on the country or area you are in, the AC wall outlet may be shaped differently and the charger may require a plug adapter to match the wall outlet.
- Do not use commercially available travel adapters as the charger may malfunction.

Usable cards

In this manual, all storage devices are referred to as “cards”. The following types of SD memory card (commercially available) can be used with this camera: SD, SDHC, and SDXC. For the latest information, please visit the Olympus website.



SD card write protect switch

The SD card body has a write protect switch. Setting the switch to “LOCK” prevents data being written to the card. Return the switch to the unlock position enable writing.

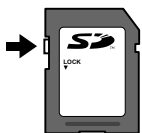

- The data in the card will not be erased completely even after formatting the card or deleting the data. When discarding, destroy the card to prevent leakage of personal information.
- Access to some playback functions and the like may be restricted when the write-protect switch is in the “LOCK” position.

Interchangeable lenses

Choose a lens according to the scene and your creative intent. Use lenses designed exclusively for the Micro Four Thirds system and bearing the M.ZUIKO DIGITAL label or the symbol shown at right. With an adapter, you can also use Four Thirds System and OM System lenses. The optional adapter is required.



- When you attach or remove the body cap and lens from the camera, keep the lens mount on the camera pointed downward. This helps prevent dust and other foreign matter from getting inside the camera.
- Do not remove the body cap or attach the lens in dusty places.
- Do not point the lens attached to the camera toward the sun. This may cause the camera to malfunction or even ignite due to the magnifying effect of sunlight focusing through the lens.
- Be careful not to lose the body cap and rear cap.
- Attach the body cap to the camera to prevent dust from getting inside when no lens is attached.

■ Lens and camera combinations

Lens	Camera	Attachment	AF	Metering
Micro Four Thirds system lens	Micro Four Thirds system camera	Yes	Yes	Yes
Four Thirds system lens		Attachment possible with mount adapter	Yes*1	Yes
OM System lenses			No	Yes*2

*1 Not available during movie recording or starry sky AF.

*2 Accurate metering is not possible.

MF Clutch Lenses

The “MF clutch” (manual focus clutch) mechanism on MF clutch lenses can be used to switch between auto and manual focus simply by repositioning the focus ring.

- Check the position of the MF clutch before shooting.
- Sliding the focus ring to the AF/MF position at the end of the lens selects autofocus, while sliding it to the MF position closer to the camera body selects manual focus, regardless of the focus mode chosen with the camera.

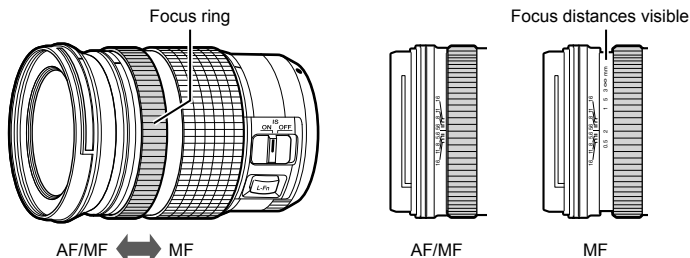

- Selecting [Inoperative] for [MF Clutch] (P. 184) in Custom Menu disables manual focus even when the MF clutch is in the MF position.

Optional Accessories

Designated External Flash Units

When using an optional flash unit designed for use with the camera, you can choose the flash mode using camera controls and take pictures with the flash. See the documentation provided with the flash unit for information on flash features and their use.

Choose a flash unit to suit your needs, taking into consideration such factors as the output required and whether the unit supports macro photography. Flash units designed to communicate with the camera support a variety of flash modes, including TTL auto and super FP. Flash units can be mounted on the camera hot shoe or connected using a cable (available separately) and flash bracket. The camera also supports the following wireless flash control systems:

Radio-Controlled Flash Photography: CMD, ⚡CMD, RCV, and X-RCV Modes

The camera controls one or more remote flash units by means of radio signals. The range of locations in which flash units can be placed increases. Flash units can control other compatible units or be fitted with radio commander/receivers to allow the use of units that do not otherwise support radio flash control.

Wireless Remote-Control Flash Photography: RC Mode

The camera controls one or more remote flash units by means of optical signals. The flash mode can be selected using camera controls (P. 105).

■ Features Available with Compatible Flash Units

Flash unit	Supported flash control modes	GN (Guide Number, ISO 100)	Supported wireless systems
FL-700WR	TTL-AUTO, MANUAL, FP TTL AUTO, FP MANUAL, MULTI, RC, SL MANUAL	GN 42 (75/150 mm ^{*1}) GN 21 (12/24 mm ^{*1})	CMD, ⚡CMD, RCV, X-RCV, RC
FL-900R	TTL-AUTO, AUTO, MANUAL, FP TTL AUTO,	GN 58 (100/200 mm ^{*1}) GN 27 (12/24 mm ^{*1})	RC
FL-600R	FP MANUAL, MULTI, RC, SL AUTO, SL MANUAL	GN 36 (42.5/85 mm ^{*1}) GN 20 (12/24 mm ^{*1})	RC
STF-8	TTL-AUTO, MANUAL, RC ^{*2}	GN 8.5	RC ^{*2}
FL-LM3	Varies with camera settings.	GN 9.1 (12/24 mm ^{*1})	RC ^{*2}

*1 Maximum lens focal length at which unit can provide flash coverage (figures following slashes are 35 mm format equivalent focal lengths).

*2 Functions as commander (transmitter) only.

Wireless remote control flash photography

Wireless flash photography is available with compatible flash units that support wireless remote control (RC). The remote flash units are controlled via a unit mounted on the camera hot shoe. Settings can be adjusted separately for the camera-mounted unit and units in up to three other groups.

RC mode must be enabled on both the master and remote flash units (P. 287).

■ Enabling RC Mode

- 1 Set the remote flash units to RC mode and place them as desired.
 - Turn the external flash units on, press the **MODE** button, and select RC mode.
 - Select a channel and group for each external flash unit.
- 2 Select [On] for [**RC Mode**] (P. 193) in **Custom Menu F** and press the **OK** button.
 - The camera will exit to the shooting display.
 - An **RC** icon will be displayed.



- 3 Press the **OK** button.
 - The RC mode super control panel will be displayed.
 - The standard LV super control panel can be displayed by pressing the **INFO** button. The display will change each time the **INFO** button is pressed.



RC mode super control panel

4 Adjust flash settings.

- Highlight items using the Δ ∇ \langle \rangle buttons and rotate the rear dial to choose settings.

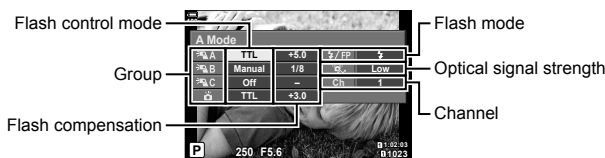

Group	Choose a group. Changes to settings apply to all units in the selected group. Choose to adjust settings for the unit mounted on the camera.
Flash control mode	Choose a flash mode.
Flash compensation	Adjust flash output. When [Manual] is selected for flash mode, you can a value for manual flash output.
Optical signal strength	Choose the brightness of the optical control signals emitted by the flash units. Choose [HI] if you have placed flash units at close to the maximum distance from the camera. This setting applies to all groups.
Flash mode/ flash level	Choose (standard) or FP (super FP). Choose super FP for shutter speeds faster than the flash sync speed. This setting applies to all groups.
Channel	Choose the channel used for flash control. Change the channel if you find that other light sources in the area are interfering with remote flash control.

5 Set the unit mounted on the camera to [TTL AUTO].

- Flash control settings for the FL-LM3 can only be adjusted using the camera.

■ Positioning Remote Flash Units

1 Set the wireless RC flash units to RC mode.

- After turning compatible flash units on, press the **MODE** button and choose RC mode.
- Choose a group for each of the compatible flash units using flash controls and match the channel to that selected with the camera.

2 Position the flash units.

- Position the wireless units with the remote sensors facing the camera.

3 Take pictures after confirming that the remote units and the unit on the camera are charged.

■ Wireless Flash Control Range

The illustration is intended as a guide only. The flash control range varies with the type of flash mounted on the camera and the conditions in the surrounding area.

Flash Control Range for Camera-Mounted FL-LM3 Flash Units

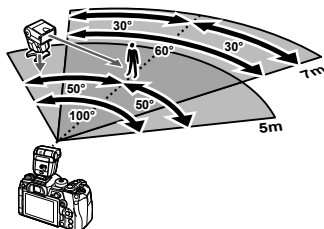

- We recommend that each group contain no more than 3 flash units.
- Wireless flash photography is not available in anti-shock mode or in rear-curtain slow sync mode when a shutter speed slower than 4 s is selected.
- Start wait times longer than 4 s cannot be selected in anti-shock and silent modes.
- Flash control signals may interfere with exposure if subject is too close to the camera. This can be mitigated by reducing the brightness of the camera flash, for example by using a diffuser.

Other external flash units

Note the following when using a third-party flash unit mounted on the camera hot shoe:

- Using obsolete flash units that apply currents of more than about 250 V to the X-contact will damage the camera.
- Connecting flash units with signal contacts that do not conform to Olympus specifications may damage the camera.
- Select mode **M**, choose a shutter speed no faster than the flash sync speed, and set [ISO] to [AUTO].
- Flash control can only be performed by manually setting the flash to the ISO sensitivity and aperture values selected with the camera. Flash brightness can be adjusted by adjusting either ISO sensitivity or aperture.
- Use a flash with an angle of illumination suited to the lens. Angle of illumination is usually expressed using 35-mm format equivalent focal lengths.

Principal Accessories

■ Remote cable (RM-CB2)

Use when the slightest camera movement can result in blurred pictures, for example for macro or bulb photography. Connect the cable to the camera remote cable terminal (P. 17).

■ Converter lenses

Converter lenses attach to the camera lens for quick and easy fish-eye or macro photography. See the OLYMPUS website for information on the lenses that can be used.

■ Eyecup (EP-13)

You can switch to a large-size eyecup.

Removal

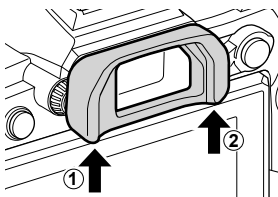

System chart

Power Supply



BLH-1
Lithium-ion battery



BCH-1
Lithium-ion Charger



F-5AC
USB-AC Adapter

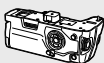

HLD-9
Power Battery Holder

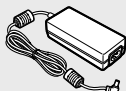

AC-5
AC Adapter

Viewfinder

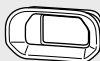

EP-13
Eyecup

Remote Operation

RM-CB2
Remote Cable

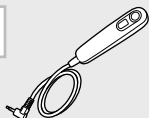

Case / Strap

Shoulder Strap /
Camera Case

Connection Cable

USB Cable /
HDMI Cable*1

Memory Card

SD/SDHC/
SDXC

E-M1 Mark III

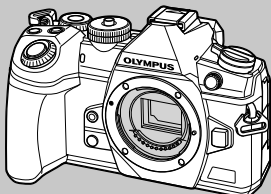

Headphone

Microphone

Software

Olympus Workspace
Digital Photo Managing Software

 : E-M1 Mark III compatible products

 : Commercially available products

For the latest information, please visit the Olympus website.

*1 HDMI cables are available from third-party suppliers.

*2 There are restrictions on the lenses that can be used with the adapter. Visit the OLYMPUS website for details.

*3 Visit the OLYMPUS website for information on compatible lenses.

Lens



Micro Four Thirds system lenses



MMF-2/MMF-3²
Four Thirds Adapter



Four Thirds system
lenses

Converter Lens*3

FCON-P01
Fisheye

WCON-P01
Wide

MCON-P01
Macro

MCON-P02
Macro

Flash



FL-LM3
Electronic Flash



FL-900R
Electronic Flash



FL-700WR
Electronic Flash

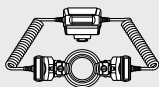

STF-8
Macro Flash



FC-WR
Wireless Radiowave
Commander



FR-WR
Wireless Radiowave
Receiver

Cleaning and storing the camera

Cleaning the camera

Turn off the camera and remove the battery before cleaning the camera.

- Do not use strong solvents such as benzene or alcohol, or a chemically treated cloth.

Exterior:

- Wipe gently with a soft cloth. If the camera is very dirty, soak the cloth in mild soapy water and wring well. Wipe the camera with the damp cloth and then dry it with a dry cloth. If you have used the camera at the beach, use a cloth soaked in clean water and well wrung.

Monitor:

- Wipe gently with a soft cloth.

Lens:

- Blow dust off the lens with a commercially available blower. For the lens, wipe gently with a lens cleaning paper.

Storage

- When not using the camera for a prolonged period, remove the battery and card. Store the camera in a cool, dry place that is well ventilated.
- Insert the battery periodically and test the camera's functions.
- Remove dust and other foreign matter from the body and rear caps before attaching them.
- Attach the body cap to the camera to prevent dust from getting inside when no lens is attached. Be sure to replace the front and rear lens caps before putting the lens away.
- Clean the camera after use.
- Do not store with insect repellent.
- Avoid storing the camera in places where chemicals are treated, in order to protect the camera from corrosion.
- Mold may form on the lens surface if the lens is left dirty.
- Check each part of the camera before use if it has not been used for a long time. Before taking important pictures, be sure to take a test shot and check that the camera works properly.

Cleaning and checking the image pickup device

This camera incorporates a dust reduction function to keep dust from getting on the image pickup device and to remove any dust or dirt from the image pickup device surface with ultrasonic vibrations. The dust reduction function operates when the camera is turned on.

The dust reduction function operates at the same time as the pixel mapping, which checks the image pickup device and image processing circuitry. Since dust reduction is activated every time the camera's power is turned on, the camera should be held upright for the dust reduction function to be effective.

Pixel Mapping - Checking the image processing functions

The pixel mapping feature allows the camera to check and adjust the image pickup device and image processing functions. For best results, wait at least a minute after shooting and playback have ended before performing pixel mapping.

- 1 In **⚙** Custom Menu **1**, select [Pixel Mapping] (P. 198).
 - 2 Press **▶**, then press the **ⓧ** button.
 - The [Busy] bar is displayed when pixel mapping is in progress. When pixel mapping is finished, the menu is restored.
- If you accidentally turn the camera off during pixel mapping, start again from Step 1.

Shooting tips and information

The camera does not turn on even when a battery is loaded

The battery is not fully charged





- Charge the battery with the charger.

The battery is temporarily unable to function because of the cold

- Battery performance drops at low temperatures. Remove the battery and warm it by putting it in your pocket for a while.

No picture is taken when the shutter button is pressed

The camera has turned off automatically

- If [On] is selected for [Quick Sleep Mode] (P. 199), the camera will enter sleep mode if no operations are performed for a set period. Press the shutter button halfway to exit the sleep mode.
- The camera automatically enters sleep mode to reduce the drain on the battery if no operations are performed for a set period of time.   Custom Menu **12** > [Sleep] (P. 199)
If no operations are performed for a set time after the camera has entered sleep mode, the camera will turn off automatically.   Custom Menu **12** > [Auto Power Off] (P. 199)

The flash is charging

- On the monitor, the  mark blinks when charging is in progress. Wait for the blinking to stop, then press the shutter button.

Unable to focus

- The camera cannot focus on subjects that are too close to the camera or that are not suited to autofocus (the AF confirmation mark will blink in the monitor). Increase the distance to the subject or focus on a high contrast object at the same distance from the camera as your main subject, compose the shot, and shoot.

Subjects that are difficult to focus on

It may be difficult to focus with auto focus in the following situations.

AF confirmation mark is blinking. These subjects are not focused.



Subject with low contrast



Excessively bright light in center of frame

AF confirmation mark lights up but the subject is not focused.



Subjects at different distances

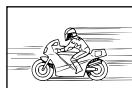

Fast-moving subject



Subject not inside AF area

Noise reduction is activated

- When shooting night scenes, shutter speeds are slower and noise tends to appear in images. The camera activates the noise-reduction process after shooting at slow shutter speeds. During which, shooting is not allowed. You can set [Noise Reduct.] to [Off].
☞ * Custom Menu [M] > [Noise Reduct.] (P. 192)

The number of AF targets is reduced

The size and number of the AF target changes depending on the [Digital Tele-converter] (P. 143), [Aspect] (P. 98), and group target (P. 69) settings.

The date and time has not been set

The camera is used with the settings at the time of purchase

- The date and time of the camera is not set when purchased. Set the date and time before using the camera. ☞ "Initial setup" (P. 33)

The battery has been removed from the camera

- The date and time settings will be returned to the factory default settings if the camera is left without the battery for approximately 1 day (in-house measurements). The settings will be canceled more quickly if the battery was only loaded in the camera for a short time before being removed. Before taking important pictures, check that the date and time settings are correct.

Set functions are restored to their factory default settings

Settings adjusted in custom modes (modes **C1–C4**) will be reset to saved values when another shooting mode is selected or the camera is turned off. If [Hold] is selected for [Reset/Custom Modes] > [Custom Mode Save Settings] in ☞ Shooting Menu 1 when a custom mode is selected, changes to settings will automatically be saved to the selected mode.

☞ "Updating Custom Modes Automatically" (P. 57)

Image taken appears whitish

This may occur when the picture is taken in backlight or semi-backlight conditions. This is due to a phenomenon called flare or ghosting. As far as possible, consider a composition where strong light source is not taken in the picture. Flare may occur even when a light source is not present in the picture. Use a lens hood to shade the lens from the light source. If a lens hood does not have effect, use your hand to shade the lens from the light.

☞ "Interchangeable lenses" (P. 285)

Unknown bright dot(s) appear on the subject in the picture taken

This may be due to stuck pixel(s) on the image pickup device. Perform [Pixel Mapping].

If the problem persists, repeat pixel mapping a few times. ☞ "Pixel Mapping - Checking the image processing functions" (P. 295)

Functions that cannot be selected from menus

Some items may not be selectable from the menus when using the arrow pad.

- Items that cannot be set with the current shooting mode.
- Items that cannot be set because of an item that has already been set:
Combinations of [☞] (P. 78) and [Noise Reduct.] (P. 192), etc.

The subject appears distorted

The following functions use an electronic shutter:

movie recording (P. 59), silent mode (P. 81), Pro Capture shooting (P. 81), High Res Shot (P. 83), focus bracketing (P. 148), focus stacking (P. 149), the live ND filter (P. 159)

This may cause distortion if the subject is moving rapidly or the camera is moved abruptly. Avoid moving the camera abruptly during shooting or use standard sequential shooting.











Lines appear in photographs









The following functions use an electronic shutter, which may result in lines due to flicker and other phenomena associated with fluorescent and LED lighting, an effect that can sometimes be reduced by choosing slower shutter speeds:

movie recording (P. 59), silent mode (P. 81), Pro Capture shooting (P. 81), High Res Shot (P. 83), focus bracketing (P. 148), focus stacking (P. 149), the live ND filter (P. 159)

Flicker can be reduced by choosing slower shutter speeds. You can also reduce flicker using flicker scan.   Custom Menu  > [ Flicker Scan] (P. 234),  Video Menu > [ Mode Settings] > [ Flicker Scan] (P. 166)

Error codes

Monitor indication	Possible cause	Corrective action
 No Card	The card is not inserted, or it cannot be recognized.	Insert a card. Or reinsert the card properly.
 ① Card Error	There is a problem with the memory card in Slot 1.	Remove and reinsert the memory card. If this does not solve the problem, format the card. If formatting fails, the card cannot be used.
 ② Card Error	There is a problem with the memory card in Slot 2.	
 ① Write Protect	The memory card in Slot 1 is write-protected ("locked").	The memory card write-protect switch is in the "LOCK" position. Return the switch to the unlocked position (P. 284).
 ② Write Protect	The memory card in Slot 2 is write-protected ("locked").	
 ① Card Full	<ul style="list-style-type: none"> Shooting disabled; the memory card in Slot 1 does not have space for additional pictures. Shooting disabled; the memory card in Slot 1 is full. 	Insert another memory or delete pictures. Before deleting pictures, be sure any pictures you wish to keep have been copied to a computer. If [Dual Independent] or [Dual Same] is selected for [Card Slot Settings] (P. 237) in  Custom Menu  , choose a different setting.
 ② Card Full	<ul style="list-style-type: none"> Shooting disabled; the memory card in Slot 2 does not have space for additional pictures. Shooting disabled; the memory card in Slot 2 is full. 	
 ① No Picture	Playback unavailable; the memory card in Slot 1 contains no pictures.	The selected memory card contains no pictures. Take pictures before choosing playback mode.
 ② No Picture	Playback unavailable; the memory card in Slot 2 contains no pictures.	

Monitor indication	Possible cause	Corrective action
 ① Picture Error	The selected file is damaged and cannot be played back. Alternatively, the picture is in a format that is not supported by the camera.	View the picture using computer imaging software or the like. If the picture cannot be displayed on a computer, the file may be corrupt.
 ② Picture Error		
 ① The Image Cannot Be Edited	Camera retouch features cannot be applied to pictures recorded with other devices.	Retouch the picture on a computer or other device.
 ② The Image Cannot Be Edited		
Y/M/D	The clock is not set.	Set the clock (P. 33).
	The internal temperature of the camera has risen due to sequential shooting.	Turn off the camera and wait for the internal temperature to cool.
 Internal camera temperature is too high. Please wait for cooling before camera use.		Wait a moment for the camera to turn off automatically. Allow the internal temperature of the camera to cool before resuming operations.
 Battery Empty	The battery is drained.	Charge the battery.
 No Connection	The camera is not correctly connected to a computer, HDMI display, or other device.	Reconnect the camera.
The lens is locked. Please extend the lens.	The lens of the retractable lens stays retracted.	Extend the lens.
Please check the status of a lens.	An abnormality has occurred between the camera and the lens.	Turn off the camera, check the connection with the lens, and turn the power on again.

Default Settings

*1: Can be added to [Assign to Custom Mode].

*2: Default can be restored by selecting [Full] for [Reset].

*3: Default can be restored by selecting [Basic] for [Reset].

Live Controls/LV Super Control Panel

Shooting mode	Item	Default	*1	*2	*3	
P/A/S/M/B	ISO	Auto	✓	✓	✓	75, 91
	Flash Mode		✓	✓	✓	86, 105
		±0	✓	✓	✓	105
	Manual Value	FULL (flash set to MANUAL])	✓	✓	✓	105
	Image Stabilizer	S-IS AUTO	✓	✓	✓	97
	Image Stabilizer	M-IS	✓	✓	✓	97
	WB	Auto ([On] selected for AUTO Keep Warm Color])	✓	✓	✓	94
	WB compensation A	±0	✓	✓	—	96
	WB compensation G	±0	✓	✓	—	
	Kelvin	5400K ([CWB] selected for [WB])	✓	✓	—	94
	AF Area	Center; Single	✓	✓	✓	69
	AF Mode	S-AF	✓	✓	✓	64, 91
	Face Priority	Face Priority Off	✓	✓	—	92
			✓	✓	✓	98
	Metering		✓	✓	✓	77
	Save Settings	Standard	✓	✓	—	99
		① F (High Res Shot: F+RAW)	✓	✓	✓	100
		② F (High Res Shot: F+RAW)	✓	✓	✓	
			✓	✓	✓	101
	Picture Mode	Natural	✓	✓	✓	106
	Sharpness	±0	✓	✓	—	110
	Contrast	±0	✓	✓	—	110
	Saturation	±0	✓	✓	—	110
	Gradation	Gradation Normal	✓	✓	—	111
	Effect	— ([i-Enhance] selected for [Picture Mode]: Standard)	✓	✓	—	113
	Color Filter	— ([Monochrome] selected for [Picture Mode]: N:None)	✓	✓	✓	112
	Monochrome Color	— ([Monochrome] selected for [Picture Mode]: N:Normal)	✓	✓	✓	113
	Aspect	4:3	✓	✓	✓	98
	Color Space	sRGB	✓	✓	✓	114

Shooting mode	Item	Default	*1	*2	*3	
P/A/S/M/B	Highlight&Shadow Control	(±0)	✓	✓	✓	115
	Movie	On	✓	✓	✓	169
(movie)	ISO	[P], [A], or [S] selected for Mode] (movie exposure mode): Auto (fixed) [M] selected for Mode] (movie exposure mode): 200	—	✓	✓	75, 91
	Flash Mode	Flash Off (fixed)	—	—	—	—
		±0 (fixed)	—	—	—	—
	Image Stabilizer	S-IS AUTO	✓	✓	✓	97
	Image Stabilizer	M-IS	✓	✓	✓	97
	WB	Auto ([On] selected for [WB AUTO Keep Warm Color])	—	✓	✓	94
	WB compensation A	±0	—	✓	—	96
	WB compensation G	±0	—	✓	—	—
	Kelvin	5400K ([CWB] selected for [WB])	—	✓	—	94
	AF Area	Center; 9-target group	✓	✓	✓	69
	AF Mode	C-AF	✓	✓	✓	64, 91
	Face Priority	Face Priority Off	✓	✓	—	92
		(fixed)	—	—	—	—
	Metering	(fixed)	—	—	—	—
	Save Settings	Standard	✓	✓	—	99
		F	✓	✓	✓	100
		F	✓	✓	✓	—
			✓	✓	✓	101
	Picture Mode	Natural	✓	✓	✓	106
	Sharpness	±0	✓	✓	—	110
	Contrast	±0	✓	✓	—	110
	Saturation	±0	✓	✓	—	110
	Gradation	Gradation Normal	✓	✓	—	111
	Aspect	16:9 (fixed) C4K selected for]: 17:9	—	—	—	—
	Color Space	sRGB (fixed)	—	—	—	—
	Highlight&Shadow Control	(±0)	✓	✓	✓	115
	Mode	P	—	✓	—	165
Movie	On	✓	✓	✓	169	

Shooting mode	Item	Default	*1	*2	*3	
RC mode	A group A	TTL	✓	✓	✓	288
	B group B	Off	✓	✓	✓	
	C group C	Off	✓	✓	✓	
	camera flash	Off	✓	✓	✓	
	Flash compensation	±0 (TTL, Auto)	✓	✓	✓	
	Flash level	1/1 (Manual)	✓	✓	✓	
	/FP	(Normal)	✓	✓	✓	
	optical signal strength	Low	✓	✓	✓	
	Channel	1	✓	✓	✓	

Shooting Menu

Tab	Function		Default	*1	*2	*3	
	Reset / Custom Modes	Reset	Basic	—	✓	—	57, 141
		Assign to Custom Mode	Shooting mode: P Image quality: F+RAW				
		Custom Mode Save Settings	Reset				
		Recall from Custom Mode	—				
	Picture Mode		Natural	✓	✓	✓	106, 142
			F (High Res Shot: F+RAW)	✓	✓	✓	100, 142
	Image Aspect		4:3	✓	✓	✓	98
	Digital Tele-converter		Off	✓	✓	✓	143
				✓	✓	✓	78
	Intrvl. Sh./Time Lapse		Off	—	✓	✓	144
	Number of Frames	99					
	Start Waiting Time	00:00:01					
	Interval Length	00:00:01					
	Time Lapse Movie	Off					
	Movie Settings	Movie Resolution	FullHD				
		Frame Rate	10fps				

Tab	Function		Default	*1	*2	*3		
2	Bracketing		Off	✓	✓	✓	146, 147, 149	
		AE BKT		3f 1.0EV				
		WB BKT	A-B	Off				
			G-M					
		FL BKT		Off				
		ISO BKT		Off				
		ART BKT		Off				
		Focus BKT		Off				
		Focus Stacking		Off				
		Set number of shots		[Off] selected for [Focus Stacking]: 99 [On] selected for [Focus Stacking]: 8				
	Set focus differential		5					
	Charge Time		0 sec	✓	✓	—		
	HDR		Off	✓	✓	✓	152	
Multiple Exposure	Number of Frames		Off	—	✓	✓	154	
	Auto Gain		Off					
	Overlay		Off					
Keystone Comp.		Off	✓	✓	✓	156		
Anti-Shock []/ Silent []	Anti-Shock []		[] 0 sec	✓	✓	—	157	
	Silent []		[] 0 sec					
	Noise Reduction []		Off					
	Silent [] Mode Settings		—	✓	✓	—		
))		Not Allow					
AF Illuminator		Not Allow						
Flash Mode		Not Allow						
High Res Shot	High Res Shot		0 sec	✓	✓	—	158	
	Charge Time		0 sec					
	Shooting Method		Handheld					
Live ND Shooting		Off	✓	✓	✓	159		
ND Number		ND8(3EV)	✓	✓	—			
LV Simulation		On	✓	✓	—			

Video Menu

Tab	Function	Default	*1	*2	*3	Info	
Video	Mode Settings	Mode	P	—	✓	—	161, 165
		Flicker Scan	Off	—	✓	✓	161, 166
	Specification Settings	MOV 4K 30p	MOV 4K 30p	✓	✓	✓	161, 167
		ISO-Auto Set					75, 161
		Upper Limit / Default	Upper Limit: 6400 Default: 200	✓	✓	✓	
		ISO-Auto	Off	—	✓	—	
		Noise Filter	Standard	✓	✓	✓	161
		WB	Auto	—	✓	✓	94, 161
		All WB	A±0, G±0	—	✓	—	96, 161
		WB AUTO Keep Warm Color	On	—	✓	✓	96, 161
	Picture Mode	Off	✓	✓	—	106, 161	
	AF/IS Settings	AF Mode	C-AF	✓	✓	✓	64, 91, 162
		C-AF Speed	±0	✓	✓	✓	162
		C-AF Sensitivity	±0	✓	✓	✓	162
		Image Stabilizer	M-IS I	✓	✓	✓	97, 162
IS Level		±0	✓	✓	✓	162	

Tab	Function	Default	*1	*2	*3				
	Button/Dial/Lever					163			
	Button Function	<input checked="" type="checkbox"/> Exposure <input checked="" type="checkbox"/> <input checked="" type="radio"/> REC <input type="checkbox"/> View Selection AEL/AFL ISO <input type="checkbox"/> [:::] <input type="checkbox"/> [:::] (Electronic Zoom) <input type="checkbox"/> [:::] (WB) <input type="checkbox"/> Peaking <input type="checkbox"/> Magnify B-Fn1 B-Fn2 PBRH↔ PBRH▶ PBRH▼ L-Fn	Exposure <input checked="" type="checkbox"/> REC View Selection AEL/AFL ISO [:::] [:::] (Electronic Zoom) [:::] (WB) Peaking Magnify ISO AEL/AFL Direct Function Electronic Zoom WB AF Stop	—	✓	—	116, 163		
	Dial Function	P	Position 1	<input checked="" type="checkbox"/> <input checked="" type="checkbox"/>	—	✓	—	163	
			Position 2	: VOL : VOL					
		A	Position 1	<input checked="" type="checkbox"/> : FNo.	—	✓	—		
			Position 2	: VOL : VOL					
		S	Position 1	<input checked="" type="checkbox"/> : Shutter	—	✓	—		
			Position 2	: VOL : VOL					
		M	Position 1	: FNo. : Shutter	—	✓	—		
			Position 2	: VOL : ISO					
		Fn Lever Function			mode2	—	✓	—	163
			mode2		AF Mode/ AF Target Mode/ AF Target Point				
		Shutter Function				—	✓	—	163
		Elec. Zoom Speed			Normal	—	✓	—	163

Tab	Function		Default	*1	*2	*3		
	Display Settings						164	
	Control Settings		Live Control, Live SCP	—	✓	—		
	Info Settings		Custom1	—	✓	—		
	Time Code Settings	Time Code Mode	Drop Frame	—	✓	—		
		Count Up	Rec Run	—	✓	—		
		Starting Time	0:00:00	—	✓	—		
	Display Pattern		min	—	✓	—		
	View Assist		Off	—	✓	—		
	Movie		On	✓	✓	✓		169
	Recording Volume	Built-in	±0	—	✓	—		
MIC		±0	—	✓	—			
Volume Limiter		On	—	✓	—			
Wind Noise Reduction		Off	—	✓	—			
Recording Rate		48kHz/16bit	✓	✓	—			
Plug-in Power		Off	—	✓	—			
Headphone Volume		8	✓	✓	—			
HDMI Output	Output Mode	Monitor Mode	—	✓	—	164		
	REC Bit	Off	✓	✓	—			
	Time Code	On	✓	✓	—			

Playback Menu

Tab	Function		Default	*1	*2	*3		
			On	✓	✓	✓	170	
	Edit	Sel. Image	RAW Data Edit	—	—	—	—	170
			JPEG Edit	—				171
			Movie Edit	—				173
				—				136
		Image Overlay	—	172				
	Print Order		—	—	—	—	134	
	Reset Protect		—	—	—	—	175	
	Reset share Order		—	—	—	—	175	
	Copy All		—	—	—	—	175	
	Wi-Fi Connect		—	—	—	—	247, 262, 264, 266	

⌋ Setup Menu

Tab	Function	Default	*1	*2	*3	👉	
⌋	Card Setup	—	—	—	—	177	
	⌚ Settings	⌚	—	—	—	33	
		Time Zone					
	🗣️	English	—	—	—	35, 176	
	📶	🇯🇵±0, 🇺🇸±0, Natural	✓	✓	—	176	
	Rec View	Off	✓	✓	—	176	
	Wi-Fi/Bluetooth Settings	Availability	On	—	✓	—	178, 246, 255, 271
		Connection Password	—	—	—	—	178, 272
		Power-off Standby	Off	—	✓	—	178, 249
		RAW+JPEG 🔄	JPEG	—	✓	—	133, 178
Reset Settings		—	—	—	—	178, 273	
Wi-Fi MAC Address		—	—	—	—	178	
Firmware	—	—	—	—	176		

⚙️ Custom Menu

Tab	Function	Default	*1	*2	*3	👉	
⚙️	AF/MF						
	📷 AF mode	S-AF	✓	✓	✓	64, 91, 181	
	📷 AF+MF	Off	✓	✓	✓	200	
	📷 AEL/AFL	S-AF	mode3	✓	✓	✓	181, 201
		C-AF	mode4				
		MF	mode3				
		📷 AF	mode3				
		Half Way AF	Operative				
	Face Priority AF	📷: On AEL/AFL: On	✓	✓	✓		
	AF Scanner	mode2	✓	✓	✓	181	
	📷 C-AF Sensitivity	±0	✓	✓	✓	203	
	📷 C-AF Center Start	📷 (All Targets)	✓	✓	✓	204	
	📷 C-AF Center Priority	5, 9, or 25 targets	✓	✓	✓	205	

Tab	Function		Default	*1	*2	*3		
	A2	[:::]Mode Settings	All; Small; 5-, 9-, or 25-target group	✓	✓	✓	182	
		AF Area Pointer	On1	✓	✓	✓	182	
		[:::] Set Home	AF Target Mode (), AF Target Point	—	✓	✓	206	
		[:::] Select Screen Settings	Set 1	✓	✓	✓	207	
			[:::]Mode					
			[:::]Mode					
			⇄ Pos					
			⇄ Pos					
		[:::] Loop Settings	[:::] Loop Selection	Off	✓	✓	✓	208
			Via	No	✓	✓	✓	
	[:::] Target Mode Settings		1×1; vertical and horizontal step size: 1	✓	✓	—	209	
	Orientation Linked [:::]		Off	✓	✓	—	210	
	A3	AF Targeting Pad		Off	✓	✓	✓	183
		AF Limiter		Off	✓	✓	✓	183
		Distance settings		Setting 1	✓	✓	✓	
		Release Priority		On	✓	✓	✓	
		AF Illuminator		On	✓	✓	✓	183
		☉Face Priority		Off	✓	✓	—	92, 183
		AF Focus Adj.*		Off	✓	✓	✓	183
	A4	Starry Sky AF Setting		Speed	✓	✓	✓	184
Preset MF distance			999.9 m	✓	✓	✓	184	
MF Assist		Magnify		Off	✓	✓	—	184,
		Peaking		Off	✓	✓	—	215
MF Clutch			Operative	✓	✓	✓	184	
Focus Ring				✓	✓	✓	184	
Bulb/Time Focusing			On	✓	✓	✓	184, 216	
Reset Lens			On	✓	✓	✓	184	

* Using [Reset] to perform a full or standard reset does not affect saved values.

Tab	Function		Default	*1	*2	*3		
	Button/Dial/Lever							
B1	Button Function		Exposure	✓	✓	—	116, 185	
			REC					
			View Selection					
			AEL/AFL					
			ISO					
			[::] (Flash Mode)					
			[::] (Flash Mode)					
			Preview					
			ISO					
			AEL/AFL					
			[::]					
			[::] (Flash Mode)					
			[::] (Flash Mode)					
			AF Stop					
			Center Button					Off
	Direction Key	[::]	✓	✓	—	185, 217		
	Dial Function	P	Position 1		✓	✓	—	185
			Position 2	: ISO : WB				
		A	Position 1	: FNo.				
			Position 2	: ISO : WB				
		S	Position 1					
			Position 2	: ISO : WB				
		M/B	Position 1	: FNo. : Shutter				
			Position 2					
		Menu		: ◀▶ : ◆/Value				
			: Prev/Next :					

Tab	Function		Default	*1	*2	*3		
	G1	Dial Direction	Exposure Ps	Dial1 Dial1	✓	✓	—	185
		Fn Lever Function	mode2	mode2	—	✓	—	185, 219
			mode2	AF Mode/ AF Target Mode/ AF Target Point				
		Fn Lever/Power Lever	Fn	—	✓	—	185	
	G2	Elec. Zoom Speed	Normal	✓	✓	—	185	
	Function	<input checked="" type="checkbox"/>	—	✓	—	185		
	Lock	Off	✓	✓	—	185		
	Lock	Off	✓	✓	—	185		
	Release/ Image Stabilizer							
	G1	S-AF Release Priority		Off	✓	✓	✓	186
	C-AF Release Priority		On	✓	✓	✓	186	
	L Settings						186, 220	
		Max fps	10 fps	✓	✓	✓		
		Frame Count Limiter	Off	✓	✓	✓		
		Max fps	18 fps	✓	✓	✓		
		Frame Count Limiter	Off	✓	✓	✓		
		Max fps	18 fps	✓	✓	✓		
		Pre-shutter Frames	8 shots	✓	✓	✓		
		Frame Count Limiter	25 shots	✓	✓	✓		
	H Settings						186, 220	
		Max fps	15 fps	✓	✓	✓		
		Frame Count Limiter	Off	✓	✓	✓		
		Max fps	60 fps	✓	✓	✓		
		Frame Count Limiter	Off	✓	✓	✓		
		Max fps	60 fps	✓	✓	✓		
		Pre-shutter Frames	14 shots	✓	✓	✓		
		Frame Count Limiter	25 shots	✓	✓	✓		
	Flicker Reduction	Anti-Flicker LV	Auto	✓	✓	—	186, 222	
		Anti-Flicker Shooting	Off	✓	✓	—		
G2	Image Stabilizer	S-IS AUTO	✓	✓	✓	97, 186		
	Image Stabilizer	Fps Priority	✓	✓	—	186		
	Half Way RIs With IS	On	—	✓	—	186		
	Lens I.S. Priority	Off	✓	✓	✓	186		

Tab	Function		Default	*1	*2	*3		
	Disp(●)/PC							
	D1	Control Settings	Live SCP	✓	✓	—	187, 224	
	/Info Settings	Info	Image Only, Overall	✓	✓	✓	187, 226	
			Info	All On	—	✓		—
		LV-Info	Image Only, Custom1 () , Custom2 (Level Gauge)	✓	✓	—		
			Informations during half way	On	✓	✓		—
			LV OFF-Info	Shooting Information	✓	✓		—
		Settings	25, Calendar	✓	✓	—		
	Picture Mode Settings		All On	✓	✓	—	187	
	/Settings		, , , , , , , ,	✓	✓	—	187	
	Multi Function Settings		All on except WB and ISO	✓	✓	—	187	
	D2	Live View Boost	Manual Shooting	Off	✓	✓	✓	188
			Bulb/Time	On2, Frame Rate Priority				
			Live Composite	Off				
			Others	Off				
		Art LV Mode		mode1	✓	✓	—	188
		Frame Rate		Normal	✓	✓	✓	188
		LV Close Up Settings	LV Close Up Mode	mode2	✓	✓	—	188
			Live View Boost	Off	✓	✓	—	
		Default Setting		Recently	—	✓	—	188
		Settings	Lock	Off	✓	✓	—	189
	Live View Boost		Off	✓	✓	—		
	D3	Grid Settings	Display Color	Preset 1	✓	✓	—	189
Displayed Grid			Off	✓	✓	—		
Apply Settings to EVF			On	✓	✓	—		
Peaking Settings		Peaking Color	Red	✓	✓	—	189	
		Highlight Intensity	Normal					
		Image Brightness Adj.	Off					
Histogram Settings		Highlight	255	✓	✓	—	189	
		Shadow	0					
Mode Guide		Off	✓	✓	—	189		
Selfie Assist		On	—	✓	—	189, 229		

Tab	Function		Default	*1	*2	*3		
	D4			On	✓	✓	✓	190
		HDMI	Output Size	1080p	—	✓	—	190, 230
			HDMI Control	Off	—	✓	—	
			Output Frame Rate	60p Priority	—	—	—	
	USB Mode		Auto	—	✓	✓	190	
	Exp/ISO/BULB/							
	E1	EV Step		1/3 EV	✓	✓	✓	191
		ISO Step		1/3 EV	✓	✓	✓	191
		ISO-Auto Set	Upper Limit / Default	Upper Limit: 6400 Default: 200	✓	✓	✓	191
			Lowest S/S Setting	Auto	✓	✓	✓	
ISO-Auto		All	✓	✓	—	191		
Noise Filter		Standard	✓	✓	✓	191		
Low ISO Processing		Drive Priority	✓	✓	✓	191		
Noise Reduct.		Auto	✓	✓	✓	192		
E2	Bulb/Time Timer		8 min	✓	✓	✓	192	
	Live Composite Timer		3h	✓	✓	✓	192	
	Bulb/Time Monitor		-7	✓	✓	—	192	
	Live Bulb		Off	✓	✓	—	192, 232	
	Live Time		0.5 sec	✓	✓	—	192, 232	
	Composite Settings		1 sec	✓	✓	—	54, 192, 233	
	Flicker Scan		Off	✓	✓	✓	192, 234	
	E3	Metering			✓	✓	✓	77, 193
AEL Metering		Auto	✓	✓	✓	193		
[∴] Spot Metering		Spot, Spot Highlight, Spot Shadow	✓	✓	✓	193		
Exposure Shift			±0	✓	✓	—	193	
			±0					
		±0						
Custom								
F	X-Sync.		1/250	✓	✓	✓	193, 236	
	Slow Limit		1/60	✓	✓	✓	193, 236	
	+		Off	✓	✓	✓	193	
	+WB		Off	✓	✓	—	193	
	RC Mode		Off	✓	✓	✓	193, 288	

Tab	Function		Default	*1	*2	*3		
	WB/Color							
		Set	←-1: SF ←-2: F ←-3: N ←-4: MN	✓	✓	✓	194, 236	
		Pixel Count	Middle 3200×2400 Small 1280×960	✓	✓	✓	194, 236	
		Shading Comp.	Off	✓	✓	✓	194	
		WB	Auto	✓	✓	✓	94, 194	
		All WB	A±0, G±0	✓	✓	—	194	
		WB AUTO Keep Warm Color	On	✓	✓	✓	194	
		Color Space	sRGB	✓	✓	✓	114, 194	
	Record/Erase							
		Card Slot Settings	Save Settings	Standard	✓	✓	—	99, 195, 237
			Save Slot	1	✓	✓	—	
			Save Slot	1	✓	✓	—	
			Slot	1	✓	✓	—	
			Assign Save Folder	Do not assign	✓	✓	—	
			File Name	Reset	✓	✓	—	195
			Edit Filename	Off	✓	✓	—	195
			dpi Settings	350dpi	✓	✓	—	195
		Copyright Settings*	Copyright Info.	Off	✓	✓	—	195
			Artist Name	—	—	—	—	
	Copyright Name		—	—	—	—		
		Lens Info Settings*	Off	—	✓	—	195, 239	
		Quick Erase	Off	✓	✓	✓	196	
		RAW+JPEG Erase	RAW+JPEG	✓	✓	✓	196	
		Priority Set	No	✓	✓	✓	196	
	EVF							
		EVF Auto Switch		On1	—	✓	—	196
		EVF Adjust	EVF Auto Luminance	On	✓	✓	—	196
			EVF Adjust	±0, ±0				
		EVF Style		Style 3	—	✓	—	196, 240
		Info Settings		Basic Information, Custom1, Custom2	✓	✓	—	196
EVF Grid Settings		Display Color	Preset 1	✓	✓	—	197	
		Displayed Grid	Off	✓	✓	—		
Half Way Level		On	✓	✓	—	197		
S-OVF		Off	✓	✓	✓	197		

* Using [Reset] to perform a full or standard reset does not affect saved values.

Tab	Function		Default	*1	*2	*3		
	Utility							
		Pixel Mapping		—	—	—	—	198, 295
		Press-and-hold Time	End LV	0.7 sec	✓	✓	—	198
			Reset LV Frame	0.7 sec	✓	✓	—	
			End	0.7 sec	✓	✓	—	
			Reset Frame	0.7 sec	✓	✓	—	
			Reset	0.7 sec	✓	✓	—	
			Reset	0.7 sec	✓	✓	—	
			Reset	0.7 sec	✓	✓	—	
			Reset	0.7 sec	✓	✓	—	
			Reset	0.7 sec	✓	✓	—	
			Call EVF Auto Switch	0.7 sec	✓	✓	—	
			End	0.7 sec	✓	✓	—	
			End	0.7 sec	✓	✓	—	
			Reset	0.7 sec	✓	✓	—	
		Switch Lock	0.7 sec	✓	✓	—		
		Call BKT Settings	0.7 sec	✓	✓	—		
		End Flicker Scan	0.7 sec	✓	✓	—		
	Level Adjust		—	—	✓	—	198	
	Touchscreen Settings		On	—	✓	—	198	
	Menu Recall		Recall	✓	✓	—	198	
	Fisheye Compensation		Off	✓	✓	—	198, 242	
		Battery Settings	Battery Priority	PBH Battery	✓	✓	—	198
			Battery Status	—	—	—	—	
		Backlit LCD		Hold	✓	✓	✓	198
		Sleep		1 min	✓	✓	✓	199
		Auto Power Off		4h	✓	✓	✓	199
Quick Sleep Mode		Off	✓	✓	—	199		
Backlit LCD		8 sec	✓	✓	—			
Sleep		10 sec	—	—	—			
Certification		—	—	—	—	199		

Memory Card Capacity

Memory Card Capacity: Photos

Figures are for a 16 GB SD card used to record photos with an aspect ratio of 4:3.

Record mode	Image size (Pixel Count)	Compression ratio	File format	File size (MB) (approx.)	Number of storable still pictures
80M F+RAW	(Tripod) 10368×7776	Loss-less compression	ORF	(Tripod) 181.4	(Tripod) 80
	10368×7776	1/4	JPEG		
	5184×3888	Loss-less compression	ORI		
50M F+RAW	(Tripod) 10368×7776	Loss-less compression	ORF	(Tripod) 168.2	(Tripod) 87
	(Handheld) 8160×6120				
	8160×6120	1/4	JPEG	(Handheld) 121.3	(Handheld) 120
	5184×3888	Loss-less compression	ORI		
25M F+RAW	(Tripod) 10368×7776	Loss-less compression	ORF	(Tripod) 157.5	(Tripod) 94
	(Handheld) 8160×6120				
	5760×4320	1/4	JPEG	(Handheld) 110.6	(Handheld) 133
	5184×3888	Loss-less compression	ORI		
80M F	10368×7776	1/4	JPEG	34.9	394
50M F	8160×6120	1/4	JPEG	21.7	634
25M F	5760×4320	1/4	JPEG	10.9	1261
RAW	5184×3888	Loss-less compression	ORF	21.7	690
1SF		1/2.7	JPEG	13.1	1054
1F		1/4		8.9	1550
1N		1/8		4.6	3013
1/2SF		1/2.7		5.1	2697
1/2F		1/4		3.6	3906
1/2N		1/8		1.9	7397
1/4SF		1/2.7		2.0	6975
1/4F	1/4	1.4		9765	
1/4N	1920×1440	1/8	0.9	16836	

Record mode	Image size (Pixel Count)	Compression ratio	File format	File size (MB) (approx.)	Number of storable still pictures
SF	1280×960	1/2.7	JPEG	1.0	13562
F		1/4		0.8	18083
N		1/8		0.5	28721
SF	1024×768	1/2.7		0.8	18779
F		1/4		0.6	24413
N		1/8		0.3	61032

- The number of storable still pictures may change according to the subject, whether or not print reservations have been made, and other factors. In certain instances, the number of storable still pictures displayed on the monitor will not change even when you take pictures or erase stored images.
- The actual file size varies according to the subject.
- The maximum number of storable still pictures displayed on the monitor is 9999.

Memory Card Capacity: Movies

Figures are for a 32 GB SDHC memory card.

Frame size	Compression	Frame rate	Capacity (approx.)
C4K	—	24p	17 minutes
4K	—	30p, 25p, 24p	39 minutes
FHD	A-I	30p, 25p, 24p	20 minutes
	SF	60p, 50p, 30p, 25p, 24p	1 hour 14 minutes
	F		2 hours 2 minutes
N	3 hours 11 minutes		
HD	A-I	60p, 50p, 30p, 25p, 24p	39 minutes
	SF		2 hours 19 minutes
	F		3 hours 55 minutes
	N		5 hours 5 minutes

- Figures are for footage recorded at the maximum frame rate. The actual bit rate varies with the frame rate and scene recorded.
- Individual movie files can be up to 4 GB in size. A new file is created when the size of the current file reaches 4 GB.
- Individual movies can be no more than 29 minutes in length.

Specifications

■ Camera

Product type	
Product type	Digital camera with interchangeable Micro Four Thirds Standard lens system
Lens	M.ZUIKO DIGITAL, Micro Four Thirds System Lens
Lens mount	Micro Four Thirds mount
Equivalent focal length on a 35 mm film camera	Approx. twice the focal length of the lens
Image pickup device	
Product type	4/3" Live MOS sensor
Total no. of pixels	Approx. 21.77 million pixels
No. of effective pixels	Approx. 20.37 million pixels
Screen size	17.4 mm(H) × 13.0 mm(V)
Aspect ratio	1.33 (4:3)
Viewfinder	
Type	Electronic viewfinder with eye sensor
No. of pixels	Approx. 2.36 million dots
Magnification	100%
Eye point	Approx. 21 mm (-1 m ⁻¹)
Live view	
Sensor	Uses Live MOS sensor
Magnification	100%
Monitor	
Product type	3.0" TFT color LCD, Vari-angle, touch screen
Total no. of pixels	Approx. 1.04 million dots (aspect ratio 3:2)
Shutter	
Product type	Computerized focal-plane shutter
Shutter speed	1/8000 - 60 sec., bulb photography, time photography
Flash sync speed	Up to 1/250 sec.
Auto focus	
Product type	Hi-Speed Imager AF
Focusing points	121 points
Selection of focusing point	Auto, Optional
Exposure control	
Metering system	TTL metering system (imager metering) Digital ESP metering/Center weighted averaging metering/Spot metering
Metered range	-2 to 20 EV (f/2.8, ISO 100 equivalent)
Shooting modes	P : Program AE (program shift available); A : Aperture priority AE; S : Shutter-priority AE; M : Manual; B : Bulb (bulb, time, and composite); C1/C2/C3/C4 : Custom Modes; MOV : Movie
ISO sensitivity	L64; L100; 200 - 25600 in steps of 1/3 or 1 EV
Exposure compensation	±5.0 EV (1/3, 1/2, 1 EV step)

White balance	
Mode setting	Auto/Preset WB (7 settings)/Customized WB/One-touch WB (camera can store up to 4 settings)
Recording	
Memory	SD, SDHC and SDXC UHS-II compatible (Slot 1 only)
Recording system	Digital recording, JPEG (DCF2.0), RAW Data
Applicable standards	Exif 2.3, Digital Print Order Format (DPOF)
Sound with still pictures	Wave format
Movie	MPEG-4 AVC/H.264
Audio	Stereo linear PCM, 16 bit; sampling frequency 48 kHz (wave format) Stereo linear PCM, 24 bit; sampling frequency 96 kHz (wave format)
Playback	
Display format	Single-frame playback/Close-up playback/Index display/Calendar display
Drive	
Drive mode	Single frame; sequential; anti-shock; silent; Pro Capture; self-timer; High Res Shot
Sequential shooting	Up to 15 fps (□H) Up to 60 fps (♥□H, Pro CapH)
Self-timer	Operation time: 12 sec./2 sec./Customized
Energy saving function	Switch to sleep mode: 1 minute, Power OFF: 4 hours (This function can be customized.)
Flash	
Flash control mode	TTL-AUTO (TTL pre-flash mode)/MANUAL
X-Sync.	1/250 s or slower
Wireless LAN	
Compatible standard	IEEE 802.11a/b/g/n/ac*
Bluetooth®	
Compatible standard	Bluetooth Version 4.2 BLE
External connector	
USB (Type C); HDMI micro connector (type D); external flash; remote cable (ø2.5 mm mini-jack); microphone jack (ø3.5 mm stereo mini-jack); headphone jack (ø3.5 mm stereo mini-jack)	
Power supply	
Battery	Lithium-ion Battery ×1
Dimensions/weight	
Dimensions	Approx. 134.1 mm (W) × 90.9 mm (H) × 68.9 mm (D) (5.3" × 3.6" × 2.7") (excluding protrusions)
Weight	Approx. 580 g (1.3 lb.) (including battery and memory card)
Operating environment	
Temperature	-10 °C - 40 °C (14 °F - 104 °F) (operation)/ -20 °C - 60 °C (-4 °F - 140 °F) (storage)
Humidity	30% - 90% (operation)/10% - 90% (storage)
Water resistance	Type: IEC Standard publication 60529 IPX1 (applies if camera is used with Olympus water-resistant lens)

* Note that cameras have been developed in line with the different standards of the countries.

■ Lithium-ion battery

MODEL NO.	BLH-1
Type	Rechargeable Lithium-ion battery
Nominal voltage	DC 7.4 V
Nominal capacity	1720 mAh
No. of charge and discharge times	Approx. 500 times (varies with usage conditions)
Ambient temperature	0 °C - 40 °C (32 °F - 104 °F) (charging)
Dimensions	Approx. 45 mm (W) × 20 mm (H) × 53 mm (D) (1.8" × 0.8" × 2.1")
Weight	Approx. 74 g (2.6 oz.)

■ Lithium-ion charger

MODEL NO.	BCH-1
Rated input	AC 100 V - 240 V (50/60 Hz)
Rated output	DC 8.4 V, 1100 mA
Charging time	Approx. 2 hours (room temperature)
Ambient temperature	0 °C - 40 °C (32 °F - 104 °F) (operation)/ -20 °C - 60 °C (-4 °F - 140 °F) (storage)
Dimensions	Approx. 71 mm (W) × 29 mm (H) × 96 mm (D) (2.8" × 1.1" × 3.8")
Weight (without AC cable)	Approx. 85 g (3.0 oz.)

- The supplied power cable is for use exclusively with this camera. Do not use with other equipment. Do not use the camera with cables for other equipment.

- The appearance and specifications of this product are subject to change without notice or obligation on the part of the manufacturer.
- Visit the OLYMPUS website for the latest specifications.

The terms HDMI and HDMI High-Definition Multimedia Interface, and the HDMI Logo are trademarks or registered trademarks of HDMI Licensing Administrator, Inc. in the United States and other countries.

HDMI™
HIGH-DEFINITION MULTIMEDIA INTERFACE

SAFETY PRECAUTIONS

**CAUTION**RISK OF ELECTRIC SHOCK
DO NOT OPEN

CAUTION: TO REDUCE THE RISK OF ELECTRICAL SHOCK, DO NOT REMOVE COVER (OR BACK). NO USER-SERVICEABLE PARTS INSIDE. REFER SERVICING TO QUALIFIED OLYMPUS SERVICE PERSONNEL.



An exclamation mark enclosed in a triangle alerts you to important operating and maintenance instructions in the documentation provided with the product.

**WARNING** If the product is used without observing the information given under this symbol, serious injury or death may result.**CAUTION** If the product is used without observing the information given under this symbol, injury may result.**NOTICE** If the product is used without observing the information given under this symbol, damage to the equipment may result.**WARNING!**

TO AVOID THE RISK OF FIRE OR ELECTRICAL SHOCK, NEVER DISASSEMBLE, EXPOSE THIS PRODUCT TO WATER OR OPERATE IN A HIGH HUMIDITY ENVIRONMENT.

General Precautions**Read All Instructions** — Before you use the product, read all operating instructions. Save all manuals and documentation for future reference.**Power Source** — Connect this product only to the power source described on the product label.**Foreign Objects** — To avoid personal injury, never insert a metal object into the product.**Cleaning** — Always unplug this product from the wall outlet before cleaning. Use only a damp cloth for cleaning. Never use any type of liquid or aerosol cleaner, or any type of organic solvent to clean this product.**Heat** — Never use or store this product near any heat source such as a radiator, heat register, stove, or any type of equipment or appliance that generates heat, including stereo amplifiers.**Attachments** — For your safety, and to avoid damaging the product, use only accessories recommended by Olympus.**Location** — To avoid damage to the product, mount the product securely on a stable tripod, stand, or bracket.**WARNING**

- Do not use the camera near flammable or explosive gases.
- Rest your eyes periodically when using the viewfinder.

Failure to observe this precaution could result in eyestrain, nausea, or sensations similar to motion sickness. The length and frequency of the required rest varies with the individual; use your own judgement. If you feel tired or unwell, avoid using the viewfinder and if necessary consult a physician.

- Do not use the flash and LED (including AF illuminator) on people (infants, small children, etc.) at close range.
 - You must be at least 1 m (3 ft.) away from the faces of your subjects. Firing the flash too close to the subject's eyes could cause a momentary loss of vision.
- Do not look at the sun or strong lights with the camera.

- **Keep young children, infants away from the camera.**
 - Always use and store the camera out of the reach of young children and infants to prevent the following dangerous situations which could cause serious injury:
 - Becoming entangled in the camera strap, causing strangulation.
 - Accidentally swallowing the battery, cards or other small parts.
 - Accidentally firing the flash into their own eyes or those of another child.
 - Accidentally being injured by the moving parts of the camera.
- **Should you notice that the charger is emitting smoke, heat, or an unusual noise or smell, immediately cease use and unplug the charger from the power outlet, and then contact an authorized distributor or service center.**
- **Stop using the camera immediately if you notice any unusual odors, noise, or smoke around it.**
 - Never remove the batteries with bare hands, which may cause a fire or burn your hands.
- Never hold or operate the camera with wet hands. This may cause overheating, exploding, burning, electrical shocks, or malfunctions.
- **Do not leave the camera in places where it may be subject to extremely high temperatures.**
 - Doing so may cause parts to deteriorate and, in some circumstances, cause the camera to catch fire. Do not use the charger if it is covered (such as a blanket). This could cause overheating, resulting in fire.
- **Handle the camera with care to avoid getting a low temperature burn.**
 - When the camera contains metal parts, overheating can result in a low-temperature burn. Pay attention to the following:
 - When used for a long period, the camera will get hot. If you hold on to the camera in this state, a low-temperature burn may be caused.
 - In places subject to extremely cold temperatures, the temperature of the camera's body may be lower than the environmental temperature. If possible, wear gloves when handling the camera in cold temperatures.
- To protect the high-precision technology contained in this product, never leave the camera in the places listed below, no matter if in use or storage:
 - Places where temperatures and/or humidity are high or go through extreme changes. Direct sunlight, beaches, locked cars, or near other heat sources (stove, radiator, etc.) or humidifiers.
 - In sandy or dusty environments.
 - Near flammable items or explosives.
 - In wet places, such as bathrooms or in the rain.
 - In places prone to strong vibrations.
 - The camera uses a lithium-ion battery specified by Olympus. Charge the battery with the specified charger. Do not use any other chargers.
 - Never incinerate or heat batteries in microwaves, on hot plates, or in pressure vessels, etc.
 - Never leave the camera on or near electromagnetic devices. This may cause overheating, burning, or exploding.
 - Do not connect terminals with any metallic objects.
 - Take precautions when carrying or storing batteries to prevent them from coming into contact with any metal objects such as jewelry, pins, fasteners, keys, etc. The short circuit may cause overheating, exploding, or burning, which burn or damage you.
 - To prevent causing battery leaks or damaging their terminals, carefully follow all instructions regarding the use of batteries. Never attempt to disassemble a battery or modify it in any way, solder, etc.
 - If battery fluid gets into your eyes, flush your eyes immediately with clear, cold running water and seek medical attention immediately.
 - If you cannot remove the battery from the camera, contact an authorized distributor or service center. Do not try to remove the battery by force. Damage to the battery exterior (scratches, etc.) may produce heat or an explosion.
 - Always store batteries out of the reach of small children and pets. If they accidentally swallow a battery, seek medical attention immediately.
 - To prevent batteries from leaking, overheating, or causing a fire or explosion, use only batteries recommended for use with this product.
 - If rechargeable batteries have not been recharged within the specified time, stop charging them and do not use them.
 - Do not use batteries with scratches or damage to the casing, and do not scratch the battery.

- Never subject batteries to strong shocks or continuous vibration by dropping or hitting. This may cause exploding, overheating, or burning.
- If a battery leaks, has unusual odor, becomes discolored or deformed, or becomes abnormal in any other way during operation, stop using the camera, and keep away from fire immediately.
- If a battery leaks fluid onto your clothing or skin, remove the clothing and flush the affected area with clean, running cold water immediately. If the fluid burns your skin, seek medical attention immediately.
- Never use lithium-ion batteries in a low-temperature environment. Doing so may cause generation of heat, ignition, or explosion.
- The Olympus lithium-ion battery is designed to be used only for the Olympus digital camera. Do not use the battery to other devices.
- **Do not allow children or animals/pets to handle or transport batteries (prevent dangerous behaviour such as licking, putting in mouth or chewing).**

Use Only Dedicated Rechargeable Battery and Battery Charger

We strongly recommend that you use only the genuine Olympus dedicated rechargeable battery and battery charger with this camera.

Using a non-genuine rechargeable battery and/or battery charger may result in fire or personal injury due to leakage, heating, ignition or damage to the battery. Olympus does not assume any liability for accidents or damage that may result from the use of a battery and/or battery charger that are not genuine Olympus accessories.

⚠ CAUTION

- **Do not cover the flash with a hand while firing.**
- Never store batteries where they will be exposed to direct sunlight, or subjected to high temperatures in a hot vehicle, near a heat source, etc.
- Keep batteries dry at all times.
- The battery may become hot during prolonged use. To avoid minor burns, do not remove it immediately after using the camera.
- This camera uses one Olympus lithium-ion battery. Use the specified genuine battery. There is a risk of explosion if the battery is replaced with the incorrect battery type.
- Please recycle batteries to help save our planet's resources. When you throw away dead batteries, be sure to cover their terminals and always observe local laws and regulations.

⚠ NOTICE

- **Do not use or store the camera in dusty or humid places.**
- **Use SD/SDHC/SDXC memory cards only. Never use other types of cards.** If you accidentally insert another type of card into the camera, contact an authorized distributor or service center. Do not try to remove the card by force.
- Regularly back up important data to a computer or other storage device to prevent accidental loss.
- OLYMPUS accepts no liability for any loss of data associated with this device.
- Be careful with the strap when you carry the camera. It could easily catch on stray objects and cause serious damage.
- Before transporting the camera, remove a tripod and all other non-OLYMPUS accessories.
- Never drop the camera or subject it to severe shocks or vibrations.
- When attaching the camera to or removing it from a tripod, rotate the tripod screw, not the camera.
- Do not touch electric contacts on cameras.
- Do not leave the camera pointed directly at the sun. This may cause lens or shutter curtain damage, color failure, ghosting on the image pickup device, or may possibly cause fires.
- Do not leave the viewfinder exposed to a strong light source or direct sunlight. The heat may damage the viewfinder.
- Do not push or pull severely on the lens.
- Be sure to remove any water droplets or other moisture from the product before replacing the battery or opening or closing covers.
- Before storing the camera for a long period, remove the batteries. Select a cool, dry location for storage to prevent condensation or mold from forming inside the camera. After storage, test the camera by turning it on and pressing the shutter button to make sure that it is operating normally.
- The camera may malfunction if it is used in a location where it is subject to a magnetic/ electromagnetic field, radio waves, or high voltage, such as near a TV set, microwave, video game, loud speakers, large monitor unit, TV/radio tower, or transmission towers. In such cases, turn the camera off and on again before further operation.
- Always observe the operating environment restrictions described in the camera's manual.

- Insert the battery carefully as described in the operating instructions.
- Before loading, always inspect the battery carefully for leaks, discoloration, warping, or any other abnormality.
- Always unload the battery from the camera before storing the camera for a long period.
- When storing the battery for a long period, select a cool location for storage.
- Power consumption by the camera varies depending on which functions are used.
- During the conditions described below, power is consumed continuously and the battery becomes exhausted quickly.
 - The zoom is used repeatedly.
 - The shutter button is pressed halfway repeatedly in shooting mode, activating the auto focus.
 - A picture is displayed on the monitor for an extended period of time.
- Using an exhausted battery may cause the camera to turn off without displaying the battery level warning.
- If the battery's terminals get wet or greasy, camera contact failure may result. Wipe the battery well with a dry cloth before use.
- Always charge a battery when using it for the first time, or if it has not been used for a long period.
- When operating the camera with battery power at low temperatures, try to keep the camera and spare battery as warm as possible. A battery that has run down at low temperatures may be restored after it is warmed at room temperature.
- Before going on a long trip, and especially before traveling abroad, purchase extra batteries. A recommended battery may be difficult to obtain while traveling.

Using the wireless LAN/ Bluetooth® functions

- **Turn off the camera in hospitals and other locations where medical equipment is present.**
The radio waves from the camera may adversely affect medical equipment, causing a malfunction that results in an accident. Be sure to disable wireless LAN/**Bluetooth**® functions in the vicinity of medical equipment (P. 255, 271).
- **Turn off the camera when onboard aircraft.**
Using wireless devices onboard may hinder safe operation of the aircraft. Be sure to disable wireless LAN/**Bluetooth**® functions onboard aircraft (P. 255, 271).
- **Do not use this product where it may interfere with nearby radar systems.**

Monitor

- Do not push the monitor forcibly; otherwise the image may become vague, resulting in a playback mode failure or damage to the monitor.
- A strip of light may appear on the top/bottom of the monitor, but this is not a malfunction.
- When a subject is viewed diagonally in the camera, the edges may appear zigzagged on the monitor. This is not a malfunction; it will be less noticeable in playback mode.
- In places subject to low temperatures, the monitor may take a long time to turn on or its color may change temporarily.
When using the camera in extremely cold places, it is a good idea to occasionally place it in a warm place. The monitor exhibiting poor performance due to low temperatures will recover in normal temperatures.
- The monitor of this product is manufactured with high-quality accuracy, however, there may be a stuck or dead pixel on the monitor. These pixels do not have any influence on the image to be saved. Because of the characteristics, the unevenness of the color or brightness may also be found depending on the angle, but this is due to the structure of the monitor. This is not a malfunction.

Legal and Other Notices

- Olympus makes no representations or warranties regarding any damages, or benefit expected by using this unit lawfully, or any request from a third person, which are caused by the inappropriate use of this product.
- Olympus makes no representations or warranties regarding any damages or any benefit expected by using this unit lawfully which are caused by erasing picture data.

Disclaimer of Warranty

- Olympus makes no representations or warranties, either expressed or implied, by or concerning any content of these written materials or software, and in no event shall be liable for any implied warranty of merchantability or fitness for any particular purpose or for any consequential, incidental or indirect damages (including but not limited to damages for loss of business profits, business interruption and loss of business information) arising from the use or inability to use these written materials or software or equipment. Some countries do not allow the exclusion or limitation of liability for consequential or incidental damages or of the implied warranty, so the above limitations may not apply to you.
- Olympus reserves all rights to this manual.

Warning

Unauthorized photographing or use of copyrighted material may violate applicable copyright laws. Olympus assumes no responsibility for unauthorized photographing, use or other acts that infringe upon the rights of copyright owners.

Copyright Notice

All rights reserved. No part of these written materials or this software may be reproduced or used in any form or by any means, electronic or mechanical, including photocopying and recording or the use of any type of information storage and retrieval system, without the prior written permission of Olympus. No liability is assumed with respect to the use of the information contained in these written materials or software, or for damages resulting from the use of the information contained therein. Olympus reserves the right to alter the features and contents of this publication or software without obligation or advance notice.

Trademarks

- Microsoft and Windows are registered trademarks of Microsoft Corporation.
- Mac, OS X, and macOS are trademarks of Apple Inc.
- SDXC Logo is a trademark of SD-3C, LLC.
- Apical logo is a registered trademark of Apical Limited.
- Micro Four Thirds, Four Thirds, and the Micro Four Thirds and Four Thirds logos are trademarks or registered trademarks of the OLYMPUS CORPORATION in Japan, the United States, the countries of the European Union, and other countries.
- Wi-Fi is a registered trademark of the Wi-Fi Alliance.
- The Wi-Fi CERTIFIED logo is a certification mark of the Wi-Fi Alliance.
- The Bluetooth® word mark and logos are registered trademarks owned by the Bluetooth SIG, Inc. and any use of such marks by OLYMPUS CORPORATION is under license.
- The standards for camera file systems referred to in this manual are the "Design Rule for Camera File System/DCF" standards stipulated by the Japan Electronics and Information Technology Industries Association (JEITA).
- All other company and product names are registered trademarks and/or trademarks of their respective owners.

THIS PRODUCT IS LICENSED UNDER THE AVC PATENT PORTFOLIO LICENSE FOR THE PERSONAL AND NONCOMMERCIAL USE OF A CONSUMER TO (i) ENCODE VIDEO IN COMPLIANCE WITH THE AVC STANDARD ("AVC VIDEO") AND/OR (ii) DECODE AVC VIDEO THAT WAS ENCODED BY A CONSUMER ENGAGED IN A PERSONAL AND NON-COMMERCIAL ACTIVITY AND/OR WAS OBTAINED FROM A VIDEO PROVIDER LICENSED TO PROVIDE AVC VIDEO. NO LICENSE IS GRANTED OR SHALL BE IMPLIED FOR ANY OTHER USE. ADDITIONAL INFORMATION MAY BE OBTAINED FROM MPEG LA, L.L.C. SEE [HTTP://WWW.MPEGLA.COM](http://WWW.MPEGLA.COM)

The software in this camera may include third party software. Any third party software is subject to the terms and conditions, imposed by the owners or licensors of that software, under which software is provided to you.

Those terms and other third party software notices, if any, may be found in the software notice PDF file stored at

<http://www.olympus.co.jp/en/support/imsg/digicamera/download/notice/notice.cfm>



The following functions are added/modified by firmware update.

Additions/modifications by the firmware version 1.2



RAW Video Output	326
Focus Indicators for Manual Focus	328
Camera Displays for Lens SET and CALL Functions	328
Default settings	329

Additions/modifications by the firmware version 1.2

RAW Video Output

A [RAW Mode] option has been added to the video menu (**MENU** → → HDMI Output) → [Output Mode]).

Option	Description	
HDMI Output	Adjust output settings for movies recorded with the camera connected with an external device via HDMI.	—
Output Mode	<p>Choose the video output mode. When set to [Monitor Mode], image and camera information are output. The camera information is not displayed on the camera screen.</p> <p>When set to [Record Mode], only image is output. The camera information is displayed on the camera screen. Select [RAW Mode] to output to compatible HDMI devices in RAW format. RAW-format video is not saved to the camera memory card. Frame size and sound settings are adjusted using camera controls.</p> <ul style="list-style-type: none"> For information on HDMI devices that support [RAW Mode], visit the OLYMPUS website. [RAW Mode] is used to record data to which settings such as exposure compensation and white balance have not been applied. An HDMI indicator appears in the camera monitor while [RAW Mode] output is in progress. 	—

Option	Description	☞
Output Mode	<ul style="list-style-type: none"> • Video output in [RAW Mode] is not displayed in the camera monitor, but instead appears on the HDMI device. • Video output in [RAW Mode] is recorded in ProResRAW format. • During output to compatible HDMI devices in [RAW Mode], [Picture Mode] is set to [On] and [Picture Mode] to [OM-Log400]. • The following restrictions apply to settings when [RAW Mode] is selected: <ul style="list-style-type: none"> - [C4K] and [4K]: Restricted to [C4K] and [4K]. High-speed and slow- and fast-motion movies cannot be recorded. - [Image Stabilizer]: Restricted to [M-IS Off] and [M-IS 2]. - [Digital Tele-converter]: Set to [Off]. - [AF Mode]-selection for Four Thirds lenses: Restricted to [MF] and [PreMF]. 	—

■ Connecting the Camera to HDMI Devices

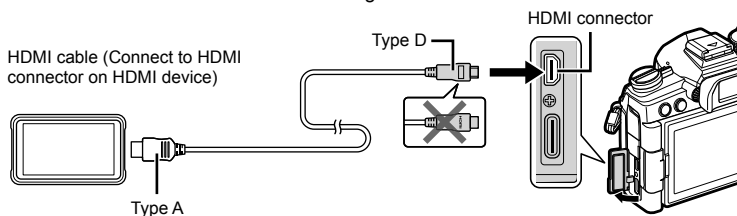

Connect the camera to the HDMI device using an HDMI cable.



- See the documentation supplied with the HDMI device for information on adjusting device settings.

Focus Indicators for Manual Focus

A [Focus Indicator] option has been added to the custom menus (**MENU** → **⚙** → **A4** → [MF Assist]).

Magnify	Magnifies a portion of the screen. The portion to be magnified can be set in advance using AF target.  “Choosing a Focus Target (AF Target Point)” (P.72)
Peaking	Displays clearly defined outlines with edge enhancement. You can select the enhancement color and intensity.  ⚙ Custom Menu D3 > [Peaking Settings] (P.189)
Focus Indicator	Rotating the focus ring during manual focus displays an indicator showing the direction and approximate amount of rotation required to bring the subject into focus. 



- These indicators may be reversed in the case of third-party lenses equipped with a focus clutch, in which case you will need to change the option selected for [Focus Ring] (P.184).
- The focus indicator is not displayed when a lens with a Four Thirds mount is used.

Camera Displays for Lens SET and CALL Functions

The camera displays “SET ●” when the focus position is saved using the SET option and “CALL ●” when a saved focus position is restored using the CALL option. For more information on SET and CALL, see the lens manual.



Default settings



The default settings for new functions and the modified default settings are as follows.

*1: Can be added to [Assign to Custom Mode].

*2: Default can be restored by selecting [Full] for [Reset].

*3: Default can be restored by selecting [Basic] for [Reset].

⚙ Custom Menu

Tab	Function		Default	*1	*2	*3	
 A4	MF Assist	Magnify	Off	✓	✓	—	184, 215
		Peaking	Off	✓	✓	—	
		Focus Indicator	Off	✓	✓	—	

Index

Symbols

(Protect)	131
(Beep sound)	190
Mode (movie exposure mode)	165
Save Slot	237
(Trimming)	171
Function	132, 133, 185
Default Setting	229
Info	187, 227
Info	187, 226
Slot	237
RC Mode	288
Slow Limit	236
X-Sync	236
+WB	193
(Index display/Calendar display)	129
Info Settings	226
(Drive Mode)	78, 98
Settings	187
H Settings	186, 220
L Settings	186, 220
Image Stabilizer	186
(Monitor brightness adjustment)	176
Mode Settings	69, 71, 182
Orientation Linked [::]	210
Save Settings	237
Save Slot	237
(Single-frame erase)	132
Select Screen Settings	207
Set Home	182, 206
Spot Metering	193
Loop Settings	208
(Language)	35, 176
(Uploading Pictures)	275
(Image selection)	133
Lock	185
(Face priority AF)	92
Face Selection	122
(Close-up playback)	129
(Image rotation)	170
Half Way Level	197

Info Settings	196
Keep Warm Color	94
Movie	161
Still image	96, 194
Target Mode Settings	209
AF+MF	193
Center Button	217
Direction Key	217
Lock	185
Settings	189
AF	64
PC RAW	231

A

A (Aperture priority mode)	46
AC adapter	25
Accessories	287, 291
AdobeRGB	114
AE bracketing	146
AEL/AFL	201
AEL Metering	193
AE lock	77, 201
AF Area Pointer	182
AF Focus Adj.	183, 212
AF Illuminator	183
AF Limiter	183
AF+MF	200
AF Mode	
Movie	162
Still image	64, 91
AF Scanner	181
AF Targeting Pad	183
AF Target Mode	69
AF Target Point	72
AF Target Selection	69, 72
AF tracking	64
All 	96
Movie	161
Still image	194
Anti-Flicker LV	186, 222
Anti-Flicker Shooting	186, 223

Anti-shock shooting	80, 157
Aperture-Priority AE	46
Apps	245
ART bracketing	147
Art Filter settings	106
Art LV Mode	188
Aspect ratio	98
Assign Save Folder	237
Assign to Custom Mode	142
Audio recording	
Movie	169
Still image	136
Auto Power Off	199
Available recording time	317

B

Backlit LCD	198
Battery charge	20, 22
Battery level	32
Battery Settings	198
Beep sound	190
Bit rate	102, 167
Bluetooth ®	246, 273
Bracketing	146
Bulb	52
Bulb/Time Focusing	184, 216
Bulb/Time Monitor	192
Bulb/Time Timer	192
Button function	116
Movie	163
Still image	185

C

Cable clip	19
C-AF Center Priority	182, 205
C-AF Center Start	182, 204
C-AF (Continuous AF)	64
C-AF Release Priority	186
C-AF Sensitivity	181, 203
C-AF+TR (AF tracking)	64
Calendar display	129, 137, 228
Card	26, 284
Card Setup	177











Card Slots	27
Card Slot Settings	237
Certification	199
Close-up playback	129
Color Creator	108
Color Filter	112
Color Space	114, 194
Composite Settings	54, 233
Compression rate	100, 102, 236, 316
Connecting via USB	22, 274, 278
Connection	
Computer	256, 274
Smartphone	245
Continuous AF	64
Contrast	110
Control Settings	
Movie	164
Still image	187, 224
Copying Pictures	
Copy	131
Copy All	175
Copyright Settings	195
Custom Menu	181, 308
Custom Mode (C1/C2/C3/C4)	56
Custom Self-timer	80
Custom Settings	183



D

Date/time setting (⌚)	33
Dial Direction	185
Dial Function	
Movie	163, 168
Still image	185
Digital Tele-converter	143
Diopter adjustment	38
dpi Settings	195
DPOF	134

E

Edit	170
Edit Filename	195
Effect (i-Enhance)	113
Electronic Zoom	121

Elec. Zoom Speed	
Movie	163
Still image	185
Erase	
All images	177
Selected images	133
Single-frame	132
EVF Adjust.....	196
EVF Auto Switch.....	196
EVF Grid Settings.....	197
EVF Style.....	240
EV Step	191
Exif data.....	195
Exposure compensation	68
Exposure Shift	193
External flash units	287
External power sources	22
Eyecup.....	291
Eye priority AF	92
F	
Face Priority	122
Face priority AF	92, 201
Fast-motion movie	104
File format.....	100, 316
File Name	195
File size	316
Firmware.....	176
Fisheye Compensation.....	242
Flash.....	84
Flash intensity control ().....	105
FL bracketing.....	147
Flicker Reduction.....	186, 222
Flicker Scan	
Movie	166
Still image	234
Fn Lever Function	
Movie	163
Still image	219
Fn Lever/Power Lever	185
Focus bracketing	148
Focus mode	64, 91
Focus Ring	184
Focus Ring Lock.....	122
Focus Stacking.....	149
Format	177
Formatting the card	177
Frame Rate	
Movie	102, 167, 317
Still image	188
Frame size.....	102, 317
G	
GPS log	254
GPS tag	254
Gradation.....	111
Grid Settings.....	189
H	
Half Way Level	197
Half Way RIs With IS	186
HDMI	190, 230, 279, 280
HDMI Control.....	282
HDMI Output.....	164
HDR (High Dynamic Range)	152
Highlight&Shadow Control.....	115
High Res Shot (High resolution shooting)	
83, 158	
Histogram display	39
Histogram Settings	189
I	
Image aspect.....	98
Image Overlay	172
Image quality	
Movie (  ).....	101, 167
Still image (  ).....	100, 142
Image quality settings	
Movie ( Specification Settings)....	161
Still image (  Set).....	194, 236
Image size	
Movie	167
Still image	100, 236, 316
Image Stabilizer.....	97, 162, 186
Index display.....	129, 137, 228
INFO button.....	39, 127
Information display	36
Playback	126

Info Settings	
 Info Settings.....	187, 226
 Info Settings.....	196
In-Movie Image Capture.....	173
Installing Apps.....	245
Installing Software.....	256
Interchangeable lenses.....	285
Intrvl. Sh./Time Lapse.....	144
ISO-Auto	
Movie.....	75, 161
Still image.....	191
ISO-Auto Set	
Movie.....	161
Still image.....	75, 191
ISO bracketing.....	147
ISO sensitivity.....	75, 91
ISO Step.....	191



K

Keystone Comp.....	156
--------------------	-----

L

Language setting ().....	35, 176
Lens Info Settings.....	239
Lens I.S. Priority.....	186
Level Adjust.....	198
Level Disp.....	120
Level Gauge.....	40
Light box display.....	226
Live Bulb.....	52, 232
Live composite photography.....	54
Live Composite Timer.....	192
Live control.....	225
Live ND Shooting.....	159
Live Time.....	52, 232
Live View Boost.....	188
Location data.....	244, 254
Long exposure (BULB/TIME).....	52
Low ISO Processing.....	191
LV Close Up Settings.....	188
LV-Info.....	187, 227
LV OFF-Info.....	187, 227
LV super control panel.....	88, 90, 301

M

M (Manual mode).....	50
Manual Exposure.....	50
Manual focus.....	64
Manual focus clutch (MF clutch).....	286
Menu.....	139, 301
Menu Recall.....	198
Metering.....	77, 92
MF (AF/MF toggle).....	118
MF Assist.....	215
MF Clutch.....	286
MF (Manual focus).....	64
Mode Guide.....	189
Monochrome Color.....	113
Movie 	169
Movie 	123, 125
Movie exposure mode.....	165
Movie playback.....	130
Movie recording.....	59, 60
Movie Trimming.....	174
Multi Function.....	124
Multi Function Settings.....	187
Multiple Exposure.....	154
My Menu.....	179

N

Noise Filter	
Movie.....	161
Still image.....	191
Noise Reduct.....	192
Number of storable still pictures.....	316

O

OI.Palette.....	245
OI.Share.....	245
OI.Track.....	245
OLYMPUS Capture.....	256, 268, 274
Olympus Workspace.....	274
One-touch white balance ().....	95, 118

P



P (Program mode).....	44
Partial Color.....	109
Peaking.....	120, 215

Peaking Settings.....	189
Picture Mode	106, 142
Picture Mode Settings	187
Pixel Count	194, 236, 316
Pixel Mapping	295
Playback	
Movie	128, 130
Still image	128
Playback Menu	170, 307
Position information	254
Power Battery Holder	24
Power lever.....	32, 185
Power-off Standby	249
PreMF (Preset MF).....	64, 67, 121
Preset MF	64, 67, 121
Preset MF distance.....	184
Press-and-hold Time	198
Preview	117
Priority Set.....	196
Pro Capture shooting.....	81
Program AE	44
Program shift (Ps)	45
Protect	131
Ps (Program shift)	45

Q

Quick Erase	196
Quick Sleep Mode	199

R

RAW Data Edit	170
RAW image	100
RAW+JPEG 	133, 178
RAW+JPEG Erase	132, 196
RC Mode ( RC Mode).....	288
Recall from Custom Mode.....	58
Rec View	176
Remote Photography.....	253
Reset	141
Reset Lens	184
Reset Protect.....	175
Reset Settings (Wi-Fi/Bluetooth)	273
Reset share Order	175
Rotate	130

S

S (Shutter priority mode).....	48
S-AF Release Priority	186
S-AF (Single AF).....	64
Saturation	110
Save Settings	99, 237
Save Slot	237
SD card.....	284
Formatting the card.....	177
Selfie Assist	229
Self-timer	78, 80, 98
Sequential shooting	78, 98
Setup Menu	176, 308
Shading Comp.....	194
Share Order.....	132
Sharpness	110
Shooting	
Movie	60
Still image	41
Shooting Menu	141, 303
Shooting modes.....	41
Shutter-Priority AE	48
Silent controls	61
Silent shooting	81, 157
Single AF	64
Sleep	32
Slow motion movie	104
Software	256
S-OVF.....	197
sRGB	114
Starry Sky AF.....	64
Starry Sky AF Setting	184
Storage.....	277
Super control panel	88, 90, 301
Super Spot AF	73

T

Test Picture.....	118
Time.....	52
Time Code Settings	164
Time Lapse Movie	144
Time lapse shooting	144
Touch AF.....	43
Touch screen operations	43, 137

Touchscreen Settings	198
TV	230

U

USB Mode	190
USB Power Delivery	278
User registration	11

V

Video Menu	161, 305
------------------	----------

W

WB

Movie	194
Still image	94
WB bracketing	146
WB Compensation.....	96
White balance.....	94, 194
White balance compensation	96
Wi-Fi/Bluetooth Settings	178, 246, 261
Wi-Fi Connection	245, 256, 260
Wireless remote control flash	288

Z

Zoom frame AF	73
---------------------	----

OLYMPUS KOREA CO., LTD.

2F-3F Majestar City 1, 12, Seocho-daero 38-gil, Seocho-gu, Seoul,
06655, Republic of Korea
Tel. 1544-3200
E-mail: hotline.okr@olympus-ap.com
<http://www.olympus.co.kr>

OLYMPUS (MALAYSIA) Sdn Bhd

512, 5th Floor, Block D, Kelana Square 17, Jalan SS 7/26, Kelana Jaya,
47301 Petaling Jaya, Selangor, Malaysia
Tel: (603) 7806 2173
Fax: (603) 7803 7164
E-mail: service.oml@olympus-ap.com
<http://www.olympus.com.my>

OLYMPUS (Thailand) CO., LTD.

23/112 Sorachai Building, 27th Floor, Soi Sukhumvit 63 (Ekamai)
Sukhumvit road Klongton Nua, Wattana, Bangkok 10110 Thailand
Tel: (66) 2-000-7700
E-mail: imaging.oth@olympus-ap.com

OLYMPUS AMERICA INC.

3500 Corporate Parkway, P.O. Box 610, Center Valley, PA 18034-0610, U.S.A. Tel. 484-896-5000

Technical Support (U.S.A. / Canada)

24/7 online automated help:
<http://www.olympusamerica.com/support>
Phone customer support:
Tel. 1-800-260-1625 (Toll-free)

Our phone customer support is available from
9 am to 9 pm (Monday to Friday) ET
<http://olympusamerica.com/contactus>
Olympus software updates can be obtained at:
<http://www.olympusamerica.com/digital>

OLYMPUS EUROPA SE & CO. KG

Premises: Consumer Product Division
Wendenstrasse 14-18, 20097
Hamburg, Germany
Tel: +49 40-23 77 3-0 / Fax: +49 40-23 07 61

Goods delivery: Modul H, Willi-Bleicher Str. 36,
52353 Düren, Germany
Mailing address: Postfach 10 49 08,
20034 Hamburg, Germany

European Technical Customer Support:

Please visit our homepage <http://www.olympus-europa.com> or call our TOLL FREE NUMBER* :
00800 - 67 10 83 00

for Austria, Belgium, Denmark, Finland, France, Germany, Luxemburg, Netherlands, Norway,
Poland, Portugal, Spain, Sweden, Switzerland, United Kingdom.

810-800 67 10 83 00 for Russia
800 167 777 for Czech Republic

* Please note some phone service providers do not permit access to 00800 numbers or require
an additional prefix. Charges may apply here. Please contact your service provider directly for
more details.

For all not listed European Countries and in case that you can't get connected to the above mentioned number,
please make use of the following CHARGED NUMBERS **+49 40 - 237 73 899**

OLYMPUS (BEIJING) SALES & SERVICE CO.,LTD

Customer Support: 400-650-0303 Homepage: <http://olympus-imaging.cn>

Customer Service Center:

10F, K, Wah Centre, 1010 Huaihai Road(M), Xuhui District, Shanghai
Zip: 200031

OLYMPUS HONG KONG AND CHINA LIMITED

OLYMPUS Customer Service Centre
Unit 13&15, 11/F, Tower 1, Kowloon Commerce Centre, No.51 Kwai Cheong Road,
Kwai Chung, New Territories, Hong Kong

Customer Hotline: +852-2376-2150 Fax: +852-2375-0630

E-mail: cs.ohc@olympus-ap.com

<http://www.olympus.com.hk>